

# STR-21G-SH

Unbeatable Accuracy, from Sunrise to Sunset



## Overview

EKO Solar Monitoring Stations are the ideal solution for highprecision solar resource assessment and projects that demand industry-leading DHI and DNI measurement accuracy, with unbeatable reliability. Built on the STR-21G platform, a singlearm, 2-axis sun tracker with an easy, fully automated setup procedure and low power consumption, the STR- 21G-S0, STR-21G-S1, and the STR-21G-S2 deliver smooth, consistent,

and precise tracking. With a variety of configurations combining the ISO 9060:2018 class-leading accuracy and performance of EKO's signature Class A MS-80S Pyranometer, Class A MS-57 Pyrheliometer and shading disk assembly, EKO solar monitoring stations are an elite solution; proven worldwide in a range of environments and ready to deliver outstanding results.

## Features



All-Weather Tracking with Integrated GPS Receiver & 4-Quadrant Sun Sensor



Quick, Easy, Fully Automated Setup



Harmonic Drive® mechanical gear system, for maximum positioning accuracy



Low Power Consumption



Easy Integration with any DAQ system



Deployed in Antarctica, proven in extreme climates worldwide

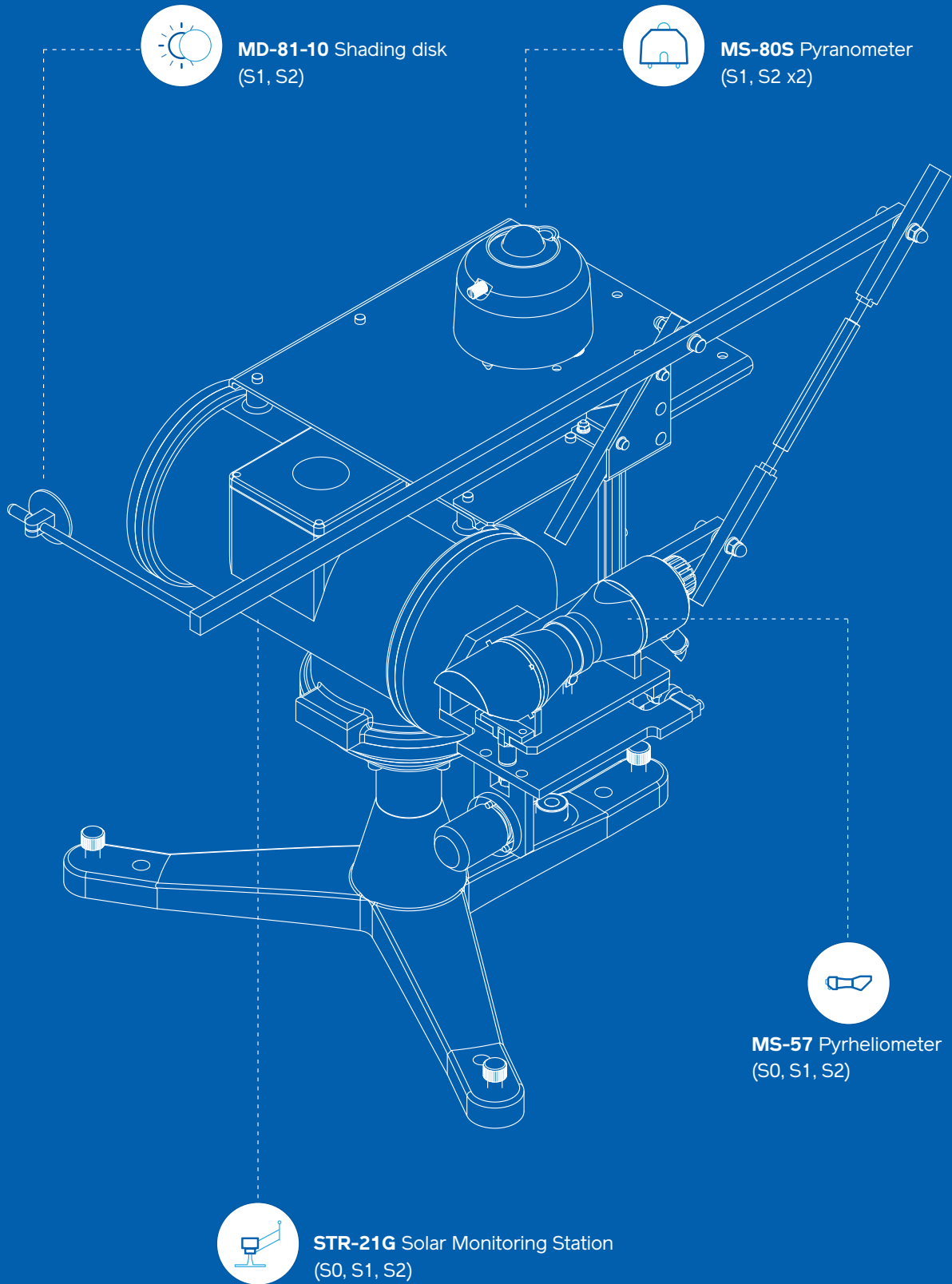



### STR-21G Sun Tracker

With integrated GPS receiver, 4-quadrant precision sun sensor, and Harmonic Drive® technology, the STR-21G Sun Tracker is built to deliver unparalleled precision, optimal positioning, and reliability, whatever the weather.

Easy to set up, the STR-21G automatically adjusts to the sun's position, even if the tracker is not perfectly oriented or levelled, and can support a range of Global, Diffuse and Direct Radiation measurement sensors for custom configurations.

The single configurable arm of the STR-21G can mount the MS-57 Class A Pyrheliometer for DNI readings and the optional MD-81-10 shading disk assembly, shielding any top-mounted pyranometer for diffuse solar radiation measurements.

### Specifications - STR-21G Sun Tracker

Arms	1
Pointing accuracy Solar elevation: 0 to 87°	<0.01°
Angle resolution	0.009°
Rotation angle Zenith	-15 - 95°
Rotation angle Azimuth	0 - 360°
Torque	12 Nm
Payload side arms	7 kg
Sun sensor FOV	30°
Ingress protection IP	65
Operating temperature range	-40 - 50°C
Communication	RS-422 / 232C
Power consumption	<20 W
Motor	Stepper motor
Driving technology	Harmonic Drive®
Tracking modes	Automatic & Manual
Tripod	Table tripod
Pyrheliometer mount	Adjustable / One sensor position
Cable length	10 m
Weight	14.5 kg (With tripod)



### MS-80SH Class A Pyranometer

Based on a revolutionary design, the MS-80S Pyranometer is best-in-class for accuracy, speed, reliability and is one of the only top tier 'fast-response' and 'spectrally flat' Class A pyranometers with unprecedented low zero-offset behaviour available.

Featuring a state-of-the-art thermopile detector and Quartz diffusor technology, new internal diagnostics, a unique 4-channel interface, and Level A EMI/EMC electronic surge filter protection, the MS-80S is IEC 61724-1 compliant and the standout choice for every application.

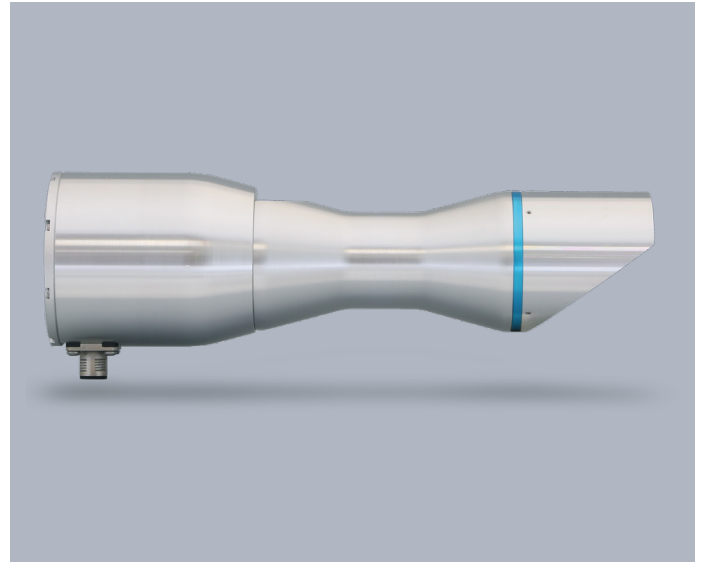

### MS-57SH Class A Pyrhelioimeter

The MS-57 Class A Pyrhelioimeter is a fast, accurate, stable, and exceptionally reliable direct normal incidence (DNI) solar irradiance sensor. 'Fast-response' and 'spectrally flat' under ISO 9060:2018 specifications, each MS-57 is calibrated outdoors and tested against reference sensors fully traceable to the World Radiometric Reference.

With an integrated low power window heater to prevent dew deposition or frost on the outside window, and competition-beating long-term stability, the MS-57 is truly 'all-weather' and perfectly suited to a range of applications.

### ISO Specifications - MS-80S & MS-57

ISO 9060:2018 Parameters	CLASS A	MS-80SH	MS-57SH
Response time 95%	<10s	<0.5s	< 0.2 Sec.
Zero offset A - Thermal Radiation (200W/m <sup>2</sup> )	± 7W/m <sup>2</sup>	± 1W/m <sup>2</sup>	0 W/m <sup>2</sup>
Zero offset B - Temperature change (5K/hr)	± 2W/m <sup>2</sup>	± 1W/m <sup>2</sup>	< 1 W/m <sup>2</sup>
Zero offset C - Total zero off-set	± 10W/m <sup>2</sup>	± 2W/m <sup>2</sup>	< 1 W/m <sup>2</sup>
Non-stability (change/year)	± 0.8%	< 0.5%/5 years	< 0.5%/5 years
Non-linearity (100 to 1000W/m <sup>2</sup> )	± 0.5%	± 0.2%	< 0.2 %
Directional Response (at 1000W/m <sup>2</sup>   0 to 80°)	± 10W/m <sup>2</sup>	± 10W/m <sup>2</sup>	± 0.5%
Spectral Error	± 0.5%	± 0.2%	± 0.2%
Temperature Response (-20°C to 50°C)	± 1%	± 0.5%	± 0.5%
Tilt Response (0-90°   1000W/m <sup>2</sup> )	± 0.5%	± 0.2%	< 0.2 %
Additional Signal Processing error	± 2W/m <sup>2</sup>	< 1 W/m <sup>2</sup>	< 1W/m <sup>2</sup>

## Technical Features

Parameters	MS-80SH	MS-57SH
Response time 95%	<0.5s	< 0.2 Sec.
Zero offset A - Thermal Radiation (200W/m <sup>2</sup> )	± 1W/m <sup>2</sup>	0 W/m <sup>2</sup>
Zero offset B - Temperature change (5K/hr)	± 1W/m <sup>2</sup>	< 1 W/m <sup>2</sup>
Zero offset C - Total zero off-set	± 2W/m <sup>2</sup>	< 1 W/m <sup>2</sup>
Non-stability (change/year)	< 0.5%/5 years	< 0.5%/5 years
Non-linearity (100 to 1000W/m <sup>2</sup> )	± 0.2%	< 0.2 %
Directional Response (at 1000W/m <sup>2</sup>   0 to 80°)	± 10W/m <sup>2</sup>	± 0.5%
Spectral Error	± 0.2%	± 0.2%
Temperature Response (-20°C to 50°C)	± 0.5%	± 0.5%
Tilt Response (0-90°   1000W/m <sup>2</sup> )	± 0.2%	< 0.2 %
Additional Signal Processing error	< 1 W/m <sup>2</sup>	< 1W/m <sup>2</sup>

## Applications

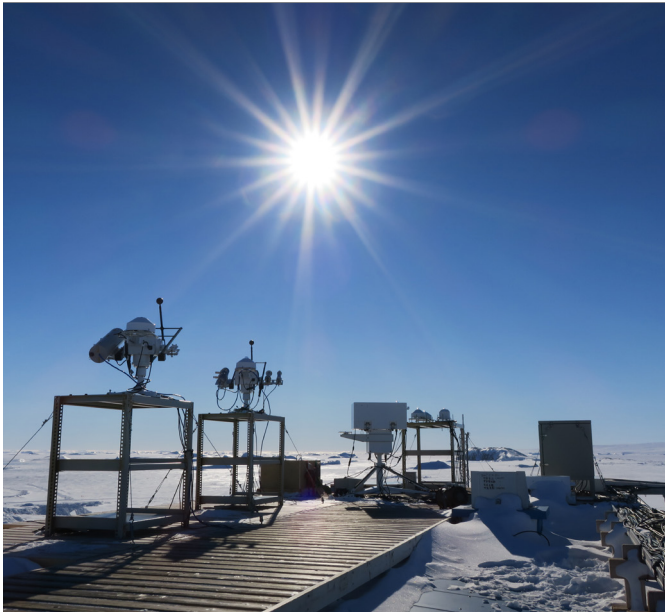

An elite solution for high-precision solar radiation measurements, the STR-21G-S1 and STR-Series sun trackers are designed for solar energy research, photovoltaic system performance monitoring, and meteorological applications. It is suitable for any application that requires the highest standards of accuracy and reliability.

## Related Products



### STR-32G Sun Tracker

The heavy-duty STR-32G Sun Tracker is the same size as other STR series sun trackers but can tackle higher torque and x4 the load without compromising precision and performance. The additional capacity makes the STR-32G the perfect option for a wide-range of Global, Diffuse and Direct Radiation measurement sensors and spectroradiometers.

The STR-32G, featuring integrated GPS and automated, easy setup, is designed for reliability and the very toughest environments and applications.

## Accessories



### MV-01

Meet IEC 61724-1 standards with the MV-01 ventilator and heater, an optional add-on that helps to reduce sensor soiling and keeps the MS-80S free from dew, ice and snow. Proven in challenging environmental conditions, the MS-80S plus MV-01 is the go-to option globally for rooftop solar stations, solar parks of all sizes, and large weather monitoring sensor networks.

### Learn More

Visit our website, contact our team, to find out more about the **STR-21G-S1** Solar Monitoring Station, related products, and the full range of Class and industry-leading products from EKO.

## Explore EKO

Made in Japan for over 90 years, EKO solar energy sensors and environmental instruments are built on a legacy of innovation, an uncompromising commitment to quality, and industry-leading accuracy.

With a range of products and services to suit every project or application requirement, explore EKO now, or get in touch to find out how EKO Instruments can help you.



Albedometers



Pyranometers



Pyrheliometers



Spectro-Radiometers



Sky Imagers



DNI Sensors



Pyrgometers



IV Measurement



Solar Monitoring Stations



Sun Trackers



Sensor Signal Converters



Heat Flux



UV Sensors



Temperature Sensors



Sky Scanners



Thermal Cond. Testers

### EKO Instruments Co. Ltd

info@eko.co.jp  
+81 3 3469 6713

### EKO Instruments Sales India

sales-in@eko-instruments.com  
+91 986 904 7721

### EKO Instruments Europe B.V.

sales-eu@eko-instruments.com  
+31 0 703 050 117

### EKO Instruments Sales China

sales-asia@eko-instruments.com  
+81 3 3469 6713

### EKO Instruments USA Inc.

sales-usa@eko-instruments.com  
+1 408 977 7751

### EKO Instruments Sales MENA

sales-mena@eko-instruments.com  
+212 661 418 870



eko-instruments.com