

INSTRUCTION MANUAL

Grating Spectroradiometer
WISER
VIS-NIR/NIR

MS-711N

MS-712

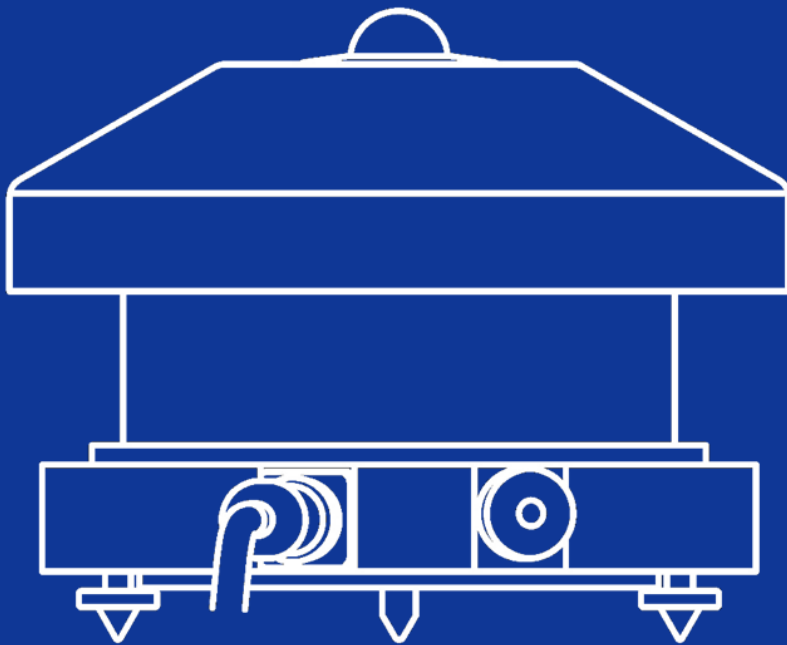

EKO

1. Index

1. Index	1
2. Important User Information	3
2-1. Contact Information	3
2-2. Warranty and Liability	3
2-3. About Instruction Manual	4
2-4. Environment	4
2-5. CE Declaration	5
3. Safety Information	7
3-1. WARNING	7
3-2. CAUTION	7
4. Introduction	8
4-1. Main Features	9
4-2. Package Contents	10
5. Getting Started	11
5-1. Parts Name and Descriptions	11
5-2. Setup Location	13
6. Software	18
6-1. Installation and Uninstallation	18
6-2. Data File Format	23
7. Measurement Software (WSDac)	25
7-1. Starting Measurement Software WSDac	25
7-2. Before Starting Measurement	26
7-3. Start Measurement	28
7-4. Measurement Data Display	30
7-5. Graph Setting	31
7-6. Graph Copy	32
7-7. Print	32
7-8. Version Information	32
8. Data Analysis Software (WSDisp)	33
8-1. Starting Data Analysis Software WSDisp.exe	33
8-2. Display Measurement Data	34
8-3. Data Setting	38
8-4. Graph Setting	39
8-5. Data Saving	40
8-6. Graph Copy	41
8-7. Print	41
8-8. Version Information	41
9. Measurement Principle	42
9-1. Measurement Principle	42
10. Maintenance & Troubleshooting	43
10-1. Maintenance	43
10-2. Calibration Method	44
10-3. Troubleshooting	44

11. Specification	45
11-1. Sensor Specifications	45
11-2. Power Supply Specification	46
11-3. Software	46
11-4. Cables	47
11-5. Dimensions	48
11-6. Accessories List	50
11-7. Consumable Items	50

2. Important User Information

Thank you for using EKO Products

Make sure to read this instruction manual thoroughly and to understand the contents before starting to operate the instrument. Keep this manual at safe and handy place for whenever it is needed.

For any questions, please contact us at one of the EKO offices given below:

2-1. Contact Information

EKO INSTRUMENTS CO., LTD.

Asia, Oceania Region

www.eko-instruments.com	EKO INSTRUMENTS Co., Ltd.	Tel: +81 [3] 3469-6713
info@eko-instruments.com	1-21-8, Hatagaya, Shibuya-ku	Fax: +81 [3] 3469-6719
	Tokyo, 151-0072 Japan	

Europe, Middle East, Africa, South America Region

www.eko-instruments.com	EKO INSTRUMENTS Europe B.V.	Tel: +31 [0]70 3050117
sales-eu@eko-instruments.com	Lulofsstraat 55, Unit 28	
	2521 AL, The Hague, The Netherlands	

North America Region

www.eko-instruments.com	EKO INSTRUMENTS USA Inc.	Tel: +1 408-977-7751
sales-usa@eko-instruments.com	2570 North First Street, Suite 200	Fax: +1 408-977-7741
	San Jose, CA 95131	

2-2. Warranty and Liability

For warranty terms and conditions, contact EKO or your distributor for further details.

EKO guarantees that the product delivered to customer has been verified, checked and tested to ensure that the product meets the appropriate specifications. The product warranty is valid only if the product has been installed and used according to the directives provided in this instruction manual.

In case of any manufacturing defect, the product will be repaired or replaced under warranty. However, the warranty does not apply if:

- Any modification or repair was done by any person or organization other than EKO service personnel.
- The damage or defect is caused by not respecting the instructions of use as given on the product brochure or the instruction manual.

2-3. About Instruction Manual

Copy Rights Reserved by EKO INSTRUMENTS CO., LTD. Making copies of whole or parts of this document without permission from EKO is prohibited.

This manual was issued: Apr. 7, 2026

Version Number: 4

2-4. Environment

1. WEEE Directive 2002/96/EC (Waste Electrical and Electronic Equipment)



In August of 2005, the European Union (EU) implemented the EU WEEE Directive 2002/96/EC and later the WEEE Recast Directive 2012/19/EU requiring Producers of electronic and electrical equipment (EEE) to manage and finance the collection, reuse, recycling and to appropriately treat WEEE that the Producer places on the EU market after August 13, 2005. The goal of this directive is to minimize the volume of electrical and electronic waste disposal and to encourage re-use and recycling at the end of life.

EKO products are subject to the WEEE Directive 2002/96/EC. EKO Instruments has labeled its branded electronic products with the WEEE Symbol (figure Trash bin) to alert our customers that products bearing this label should not be disposed of in a landfill or with municipal or household waste in the EU.

If you have purchased EKO Instruments branded electrical or electronic products in the EU and are intending to discard these products at the end of their useful life, please do not dispose of them with your other household or municipal waste. Disposing of this product correctly will help save valuable resources and prevent any potential negative effects on human health and the environment, which could otherwise arise from inappropriate waste handling.

2. RoHS Directive 2002/95/EC

EKO Instruments has completed a comprehensive evaluation of its product range to ensure compliance with RoHS Directive 2002/95/EC regarding maximum concentration values for substances. As a result all products are manufactured using raw materials that do not contain any of the restricted substances referred to in the RoHS Directive 2002/95/EC at concentration levels in excess of those permitted under the RoHS Directive 2002/95/EC, or up to levels allowed in excess of these concentrations by the Annex to the RoHS Directive 2002/95/EC.

2-5. CE Declaration



IMPORTANT USER INFORMATION



DECLARATION OF CONFORMITY

We: EKO INSTRUMENTS CO., LTD
1-21-8 Hatagaya Shibuya-ku, Tokyo
151-0072 JAPAN

Declare under our sole responsibility that the product:

Product Name: Spectroradiometer
Model No.: MS-711N

To which this declaration relates is in conformity with the following
harmonized standards of other normative documents:

Harmonized standards:

EN 61326-1:2021 Class A (Emission)
EN 61326-1:2021 (Immunity)

Following the provisions of the directive:

EMC-directive: 2014/30/EU

Date: July 14, 2025

Position of Authorized Signatory: General Manager of R & D Center

Name of Authorized Signatory: Hitoshi Yokemura

Signature of Authorized Signatory: *Hitoshi Yokemura*



DECLARATION OF CONFORMITY

We: EKO INSTRUMENTS CO., LTD
1-21-8 Hatagaya Shibuya-ku,
Tokyo 151-0072 JAPAN

Declare under our sole responsibility that the product:

Product Name: Spectroradiometer
Model No.: MS-712

To which this declaration relates is in conformity with the following harmonized standards of other normative documents:

Harmonized standards:

EN 61326:1997+A1+A2 Class A (Emission)
EN 61326:1997+A1+A2 (Immunity)
EN61000-4-2 EN61000-4-3
EN61000-4-4 EN61000-4-5
EN61000-4-6 EN61000-4-11

Following the provisions of the directive:

EMC-directive: 89/336/EEC
Amendment to the above directive: 93/68/EEC

Date: December 4, 2025

Position of Authorized Signatory: General Manager of R & D Center

Name of Authorized Signatory: Hitoshi Yokemura

Signature of Authorized Signatory: *Hitoshi Yokemura*

3. Safety Information

EKO Products are designed and manufactured with consideration for safety; however, please make sure to read and understand this instruction manual thoroughly to be able to operate the instrument safely in the correct manner.



WARNING CAUTION

Attention to user; pay attention to the instructions given on the instruction manual with this sign.



3-1. WARNING

1. Setup

- Installation base or mast should have enough load capacity to set the Grating Spectroradiometers MS-711N/712. Fix MS-711N/712 securely to the base or mast with bolts and nuts; otherwise, the instrument may drop due to gale or earthquake and may invite unexpected accidents.
- Do not use these instruments in different use other than its original purpose.
- Do not disassemble, modify or touch inside these instruments.
- Do not place these instruments in places where humidity and/or dusts exist, extreme difference in temperature of over specification range, near object which emits strong magnetic energy or electric wave. These conditions may cause damages to the instrument.
- Make sure to install these instruments where maintenance can be performed safely.



3-2. CAUTION

1. Power Supply

- Do not touch the terminals and power plug with wet hands. This will lead to electric shocks and leakages.
- Check the voltage and provided power type (AC, DC) to make sure they are suitable for the instrument specification before turning the power on.
- Use only the attached cables. Using any other cables may lead to electric shocks or leakages. EKO Instruments will not be held responsible in case of accidents or measurement accuracy by using cables other than specified by EKO.

2. Handling

- Hold the bottom part of the instrument firmly when carrying this instrument.
- Holding the cover, glass dome or any other part of this instrument can lead to damage or dropping instrument.
- Be careful with handling the glass dome.

4. Introduction

For solar spectral research, we believe only one measurement concept can be the best. The Grating Spectroradiometers MS-711N and MS-712, also called as "WISER", are references in the market and designed to provide the most accurate solar spectral data outdoors. The MS-711N and MS-712 spectroradiometer are unique all-weather concept instruments with no moving parts and temperature-controlled spectrometers, which provide seamless spectral range measurements from 300nm to 1700nm (MS-711N from 300nm and 1100nm, and MS-712 covers the near-infrared (NIR) range between 900nm and 1700nm). Both spectroradiometers are accurately calibrated with traceability to the International Standards and issued with a calibration uncertainty budget.

Temperature changes of the detector inside the spectrometer have a strong effect on the measurement uncertainty. Therefore the sensor unit inside the MS-711N and MS712 main body is accurately controlled at a stable temperature in order to provide the best performance in a wide operating temperature range. The rugged optical design of the diffusor and input optics make the MS spectroradiometer series concept superior to any fiber optic spectroradiometer which will be susceptible to mechanical vibration and handling. The MS spectroradiometer series are designed for permanent installation, but are perfectly suited as a traveling reference.

Both spectroradiometers have a separate power supply and can be controlled through RS232 / 422 by a PC or data logger. The PC software provide different functions for operating, data management and visualization. Software can also be customized to the individual user purpose by making use of the existing system control functions through the open command protocol.

Measuring spectral irradiance is a must to understand the effect of the non-uniform energy distribution of the sun. Since the solar spectrum varies as a function of air-mass and composition of the atmosphere, the MS-711N reveals those details. While thermopile pyrheliometer and pyranometer are most suitable to quantify the total DNI or global radiation (W/m^2), spectroradiometers give detail about the energy distribution ($W/m^2/nm$), which is most important for PV or CPV cell research and performance analysis.

4-1. Main Features

1. All-Weather

MS-711N/712 is designed based on our extensive experience in development, production and distribution of various kinds of meteorological instruments. MS-711N/712 can be used for continuous outdoor use as all-weather equipment.

2. High Durability

Providing accurate spectral data over a long period of time requires a stable spectrometer and robust opto-mechanical concept. All parts used in the MS-711N/712, such as dome, diffuser optics, grating and photo-diode array are designed without any moving parts.

3. Wide Measurement Range

With the automatic exposure function, MS-711N/712 can measure a wide range of solar illumination from low to high illuminance in high S/N proportion. MS-711N can measure from 300nm to 1,100nm, MS-712 can measure from 900nm to 1,700nm wavelength range; combination of them will allow taking measurements which covers the wide range of wavelength from 300nm to 1,700nm.

4. Operating Software

The operating software has different measurement functions, to make either a “single measurement” or “scheduled measurement” which takes periodical measurements every day.

Data as well as the details of the spectral data can be displayed simultaneously. It combines the data obtained from both MS-711N and MS-712, and takes re-samples and keeps the spectral data in every 1nm and automatically calculates the obtained data.

4-2. Package Contents

Check the package contents first; if any missing item or damage is noticed, please contact EKO immediately.

Table 4-1. Package Contents

Standard Items	Qty.	Remarks
Sensors	2	MS-711N x 1 unit, MS-712 x 1 unit
Set of Sensor fixing screws	1	MS-711N: Bolts: M8 x 75, Washers, Nuts (x2 each) MS-712: Bolts: M8 x 90, Washers, Nuts (x2 each)
Power supply	2	One power supply unit for each MS-711N and MS-712
Sensor cable	2	Standard Length : 10m
Power supply cable	2	Length : 2m
RS-232C cable	2	Length : 1.5m
CD-ROM	1	Software (WSDac_V3.0.x.x.exe and WSDisp_V3.0.x.x.exe) contained
Calibration Certificate	1	Includes Cosine Response Test report

5. Getting Started

5-1. Parts Name and Descriptions

Each part name and its main functions are described below. Table 5-1 and Figure 5-1 describe the sensor parts, and Table 5-2 and Figure 5-2 describe the power supply parts.

1. Sensor Part

Table 5-1. Names and functions of Sensor Part

	Name	Function
1	Spirit Level	Used for leveling the sensor base horizontally, adjust the two leveling screws to place a bubble in the center of the circle.
2	Fixing Holes	Used for fixing the instrument in leveled position. Fix the sensor for safety.
3	Diffuser	The diffuser diffuses the incident light from sky hemisphere, and it compensates the intensity of the incident light to comply with cosine characteristics.
4	Quartz Dome	Dome protects the sensor inside from soiling and effects from rain and wind, and it enhances the cosine characteristics which incident from the sky hemisphere.
5	Sensor/Power Supply Cable Connector	Connect Sensor/Power Supply Cable. Transmit power signal from power supply to sensor. Connector part is waterproofed.
6	Drying Cartridge	Used for keeping inside the sensor dry. It is necessary to replace it periodically when the desiccant color change.
7	Cover	Prevents from sensor's internal temperature increasing by solar radiation.
8	Leveling Screws	To set the sensor in horizontal position, adjust 2 screws as monitoring the spirit level.

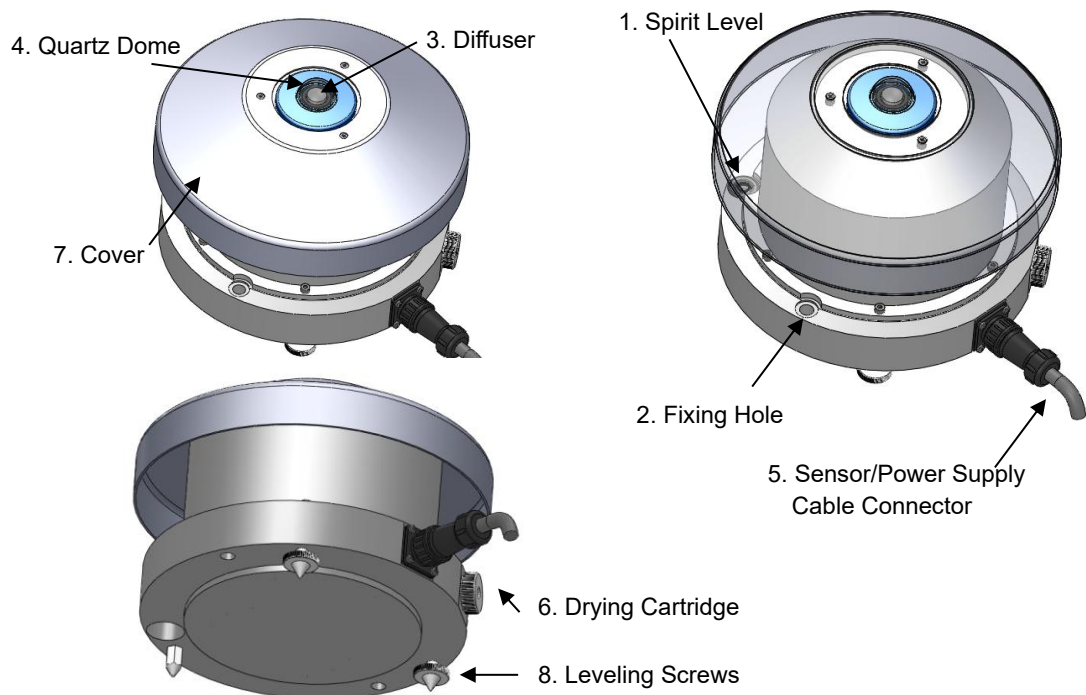

Figure 5-1. Parts Name and Function (Sensor Part)

2. Power Supply

Table 5-2. Names and functions of power supply

	Name	Function																																																																																																														
1	Power Switch	When the power switch is pushed to right side, power is ON, to left side power is OFF.																																																																																																														
2	Connector Strip Block	<p>MS-711N</p> <table border="1" data-bbox="624 389 1272 940"> <thead> <tr> <th></th> <th>Terminal block</th> <th>Wire Color</th> <th>Wire #</th> <th></th> </tr> </thead> <tbody> <tr> <td>1</td> <td>TXD+(RS-422)</td> <td>Brown</td> <td>1</td> <td></td> </tr> <tr> <td>2</td> <td>TXD-(RS-422)</td> <td>Red</td> <td>2</td> <td></td> </tr> <tr> <td>3</td> <td>RXD+(RS-422)</td> <td>Orange</td> <td>3</td> <td></td> </tr> <tr> <td>4</td> <td>RXD-(RS-422)</td> <td>Yellow</td> <td>4</td> <td></td> </tr> <tr> <td>5</td> <td>Digital GROUND</td> <td>Green</td> <td>5</td> <td></td> </tr> <tr> <td>6</td> <td>Supply Power +12V</td> <td>Gray/Blue</td> <td>6</td> <td></td> </tr> <tr> <td>7</td> <td>Supply Power ground</td> <td>White/Yellow Green</td> <td>7</td> <td>(DC GND)</td> </tr> <tr> <td>8</td> <td>Supply Power +12V</td> <td>Black</td> <td>8</td> <td></td> </tr> <tr> <td>9</td> <td>Supply Power Ground</td> <td>Pink</td> <td>9</td> <td>(DC GND)</td> </tr> <tr> <td>10</td> <td>EARTH</td> <td>Black</td> <td>10</td> <td></td> </tr> </tbody> </table> <p>MS-712</p> <table border="1" data-bbox="624 1021 1272 1572"> <thead> <tr> <th></th> <th>Terminal block</th> <th>Wire Color</th> <th>Wire #</th> <th></th> </tr> </thead> <tbody> <tr> <td>1</td> <td>TXD+(RS-422)</td> <td>Brown</td> <td>1</td> <td></td> </tr> <tr> <td>2</td> <td>TXD-(RS-422)</td> <td>Red</td> <td>2</td> <td></td> </tr> <tr> <td>3</td> <td>RXD+(RS-422)</td> <td>Orange</td> <td>3</td> <td></td> </tr> <tr> <td>4</td> <td>RXD-(RS-422)</td> <td>Yellow</td> <td>4</td> <td></td> </tr> <tr> <td>5</td> <td>Digital GROUND</td> <td>Green</td> <td>5</td> <td></td> </tr> <tr> <td>6</td> <td>Supply power +5V</td> <td>Gray/Blue</td> <td>6</td> <td></td> </tr> <tr> <td>7</td> <td>Supply power ground</td> <td>White/Yellow Green</td> <td>7</td> <td>(DC GND)</td> </tr> <tr> <td>8</td> <td>Peltier Control +12V</td> <td>Black</td> <td>8</td> <td></td> </tr> <tr> <td>9</td> <td>Peltier Control Ground</td> <td>Pink</td> <td>9</td> <td>(DC GND)</td> </tr> <tr> <td>10</td> <td>EARTH</td> <td>Black</td> <td>10</td> <td></td> </tr> </tbody> </table>		Terminal block	Wire Color	Wire #		1	TXD+(RS-422)	Brown	1		2	TXD-(RS-422)	Red	2		3	RXD+(RS-422)	Orange	3		4	RXD-(RS-422)	Yellow	4		5	Digital GROUND	Green	5		6	Supply Power +12V	Gray/Blue	6		7	Supply Power ground	White/Yellow Green	7	(DC GND)	8	Supply Power +12V	Black	8		9	Supply Power Ground	Pink	9	(DC GND)	10	EARTH	Black	10			Terminal block	Wire Color	Wire #		1	TXD+(RS-422)	Brown	1		2	TXD-(RS-422)	Red	2		3	RXD+(RS-422)	Orange	3		4	RXD-(RS-422)	Yellow	4		5	Digital GROUND	Green	5		6	Supply power +5V	Gray/Blue	6		7	Supply power ground	White/Yellow Green	7	(DC GND)	8	Peltier Control +12V	Black	8		9	Peltier Control Ground	Pink	9	(DC GND)	10	EARTH	Black	10	
	Terminal block	Wire Color	Wire #																																																																																																													
1	TXD+(RS-422)	Brown	1																																																																																																													
2	TXD-(RS-422)	Red	2																																																																																																													
3	RXD+(RS-422)	Orange	3																																																																																																													
4	RXD-(RS-422)	Yellow	4																																																																																																													
5	Digital GROUND	Green	5																																																																																																													
6	Supply Power +12V	Gray/Blue	6																																																																																																													
7	Supply Power ground	White/Yellow Green	7	(DC GND)																																																																																																												
8	Supply Power +12V	Black	8																																																																																																													
9	Supply Power Ground	Pink	9	(DC GND)																																																																																																												
10	EARTH	Black	10																																																																																																													
	Terminal block	Wire Color	Wire #																																																																																																													
1	TXD+(RS-422)	Brown	1																																																																																																													
2	TXD-(RS-422)	Red	2																																																																																																													
3	RXD+(RS-422)	Orange	3																																																																																																													
4	RXD-(RS-422)	Yellow	4																																																																																																													
5	Digital GROUND	Green	5																																																																																																													
6	Supply power +5V	Gray/Blue	6																																																																																																													
7	Supply power ground	White/Yellow Green	7	(DC GND)																																																																																																												
8	Peltier Control +12V	Black	8																																																																																																													
9	Peltier Control Ground	Pink	9	(DC GND)																																																																																																												
10	EARTH	Black	10																																																																																																													
3	RS-232C Connector	Connect RS-232C cable to PC.																																																																																																														
4	Fuse Holder	Set 2A fuse.																																																																																																														
5	AC Power Connector	Voltage range is AC100 to 240V, frequency is 50 / 60Hz.																																																																																																														

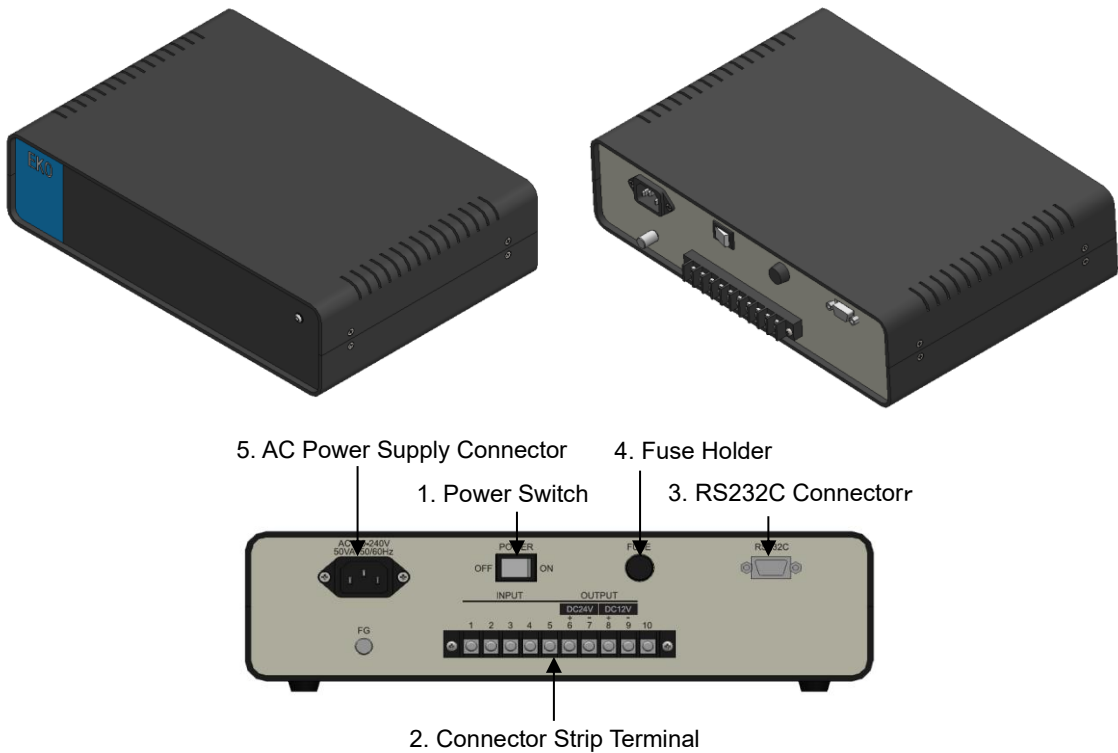

Figure 5-2. Parts Name and Function (Power Supply Part)



CAUTION: MS-711N requires only DC12V; however, MS-712 requires 2 system Voltage supplies DC5V and DC12V. Be extremely careful not to connect the power supply units to the wrong sensor units, as this will cause the product to malfunction.

CAUTION: Before switching the power on, make sure that the grid supply voltage corresponds to the rated voltage as specified.

5-2. Setup Location

1. Location

In order to obtain representative measurements from spectroradiometers, several criteria with respect to setup and mounting of the instruments have to be considered*:

The ideal mounting position for the spectroradiometer is a location which has a full hemispheric field-of-view without any obstructions (such as buildings, trees, and mountain). In practice, it might be difficult to find such locations. Therefore, some practical recommendations on how to minimize undesired effects of reflecting or obstructing surfaces are given next:

- Select a mounting position which it is free from obstructions at 5° above horizon.
- The setup location should be easily accessible for periodic maintenance (quartz dome cleaning, desiccant replacement, etc.).
- Avoid surrounding towers, poles, walls or billboards with bright colors that can reflect solar radiation onto the spectroradiometer.

2. Installing at Horizontal or tilted Positions

(1) Prepare Installation Base

Check the installation base where the MS-711N and MS-712 sensors have to be mounted and make sure it has two fixing holes with the appropriate pitch. The pitch sizes of the fixing holes are as follows (in mm):

Table 5-3. Fixing Hole Pitch and Bolt Size

	MS-711N Sensor	MS-712 Sensor
Fixing Hole Pitch	200 mm	280mm
Fixing Bolt Size	M8 x 75mm	M8 x 90mm

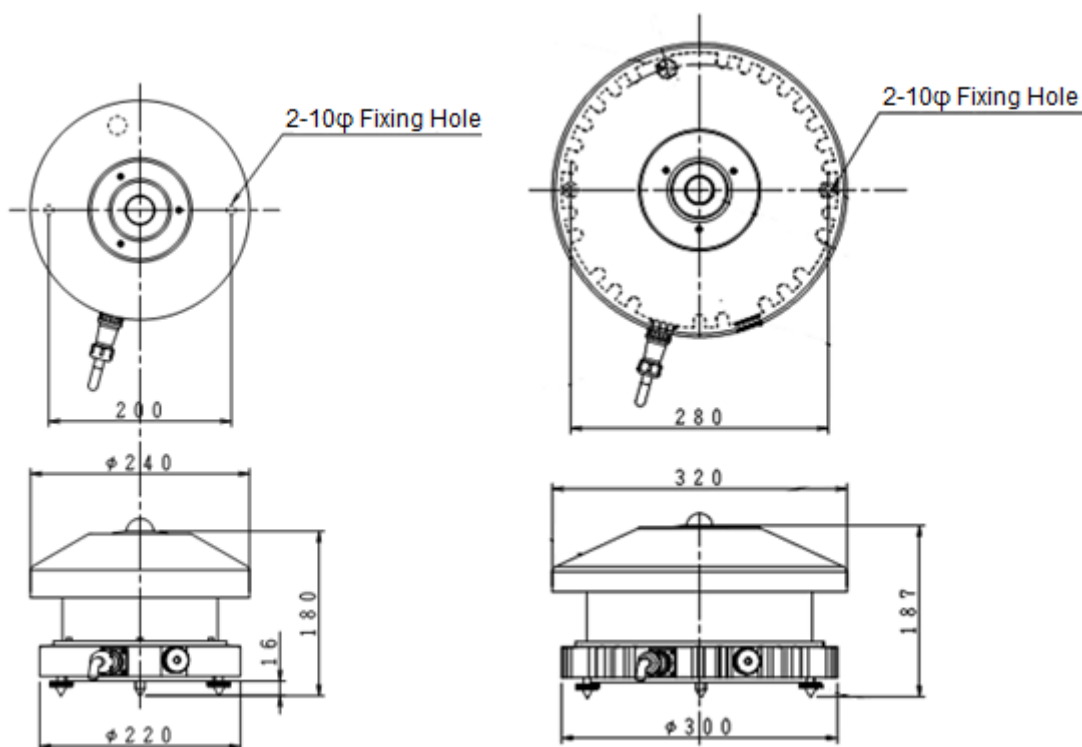

Figure 5-3. Dimensions (Left: MS-711N, Right: MS-712)

(2) Setup the MS-711N and MS-712 Sensors

Setup the sensors with the signal cable connector facing the nearest Earth's pole.

In the Northern hemisphere, the connector should be orientated North, in the Southern hemisphere, the connector should be orientated South.

(3) Leveling

Adjust the sensors in a horizontal position by using the 2 leveling screws and observing the air bubble in the spirit level while manipulating the leveling screws. The instrument is leveled horizontally if the air bubble is in the center ring. Once the instrument is leveled properly, fix the instrument with mounting bolts.

In case the sensors are mounted on a tilted plane, preferably the sensors are mounted on the leveling screws to thermally isolate the sensors from the mounting platform.

If the sensors are not leveled properly, the readings are affected by cosine and azimuth errors. Periodically check the spirit level and adjust its position if necessary.

(4) Adjust Height

To take measurements by setting up the MS-711N and MS-712 side by side, the sensor surface must be adjusted to the same height level.

(5) Cover

Place the Cover on the instrument and fasten with 3 screws (M3).

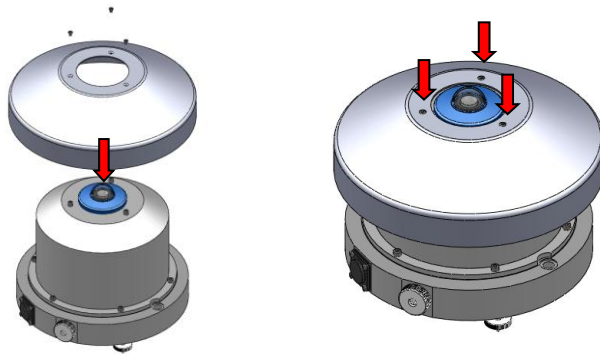

Figure 5-4. Attaching Cover

(6) Connect Sensor Cable

Connect the sensor cable connector to the sensors and the Y-terminals to the terminal block of the power supply according to the table below.

Make sure the sensor connector part is securely connected so that moisture will not enter the connector. Also fasten the cable with such as band strip so that it will not be blown by wind. If the sensors are setup on Sun Tracker, make sure to have sufficient length of cable for rotation movement.

Use + screw driver to connect the cable to lug terminals on the power supply, make sure the cable numbers and the terminal numbers match.



The power supply can't be used in an unprotected outdoors environment, as it can only be used in a dry environment.

Table 5-4. Terminal block layout and Wire colors

MS-711N Terminal Arrangement

	Terminal block	Wire Color	Wire #	
1	TXD+ (RS-422)	Brown	1	
2	TXD- (RS-422)	Red	2	
3	RXD+ (RS-422)	Orange	3	
4	RXD- (RS-422)	Yellow	4	
5	Digital GROUND	Green	5	
6	Supply Power +12V	Gray/Blue	6	
7	Supply Power ground	White/Yellow Green	7	(DC GND)
8	Supply Power +12V	Black	8	
9	Supply Power Ground	Pink	9	(DC GND)
10	EARTH	Black	10	

MS-712 Terminal Arrangement

	Terminal block	Wire Color	Wire #	
1	TXD+ (RS-422)	Brown	1	
2	TXD- (RS-422)	Red	2	
3	RXD+ (RS-422)	Orange	3	
4	RXD- (RS-422)	Yellow	4	
5	Digital GROUND	Green	5	
6	Supply power +5V	Gray/Blue	6	
7	Supply power ground	White/Yellow Green	7	(DC GND)
8	Peltier Control +12V	Black	8	
9	Peltier Control Ground	Pink	9	(DC GND)
10	EARTH	Black	10	

(7) Connect Power Supply

Connect the one end of power cable to AC power supply connector at the rear of power supply.

Then connect the other end of power cable to the socket properly. Make sure that provided power is AC100-240V, 50/60Hz, 50VA.

(8) RS-232C

Connect the PC COM port and the RS-232C connector at the back of the power supply with RS-232C cable. When connecting, insert the connector which has ferrite core to the power supply.

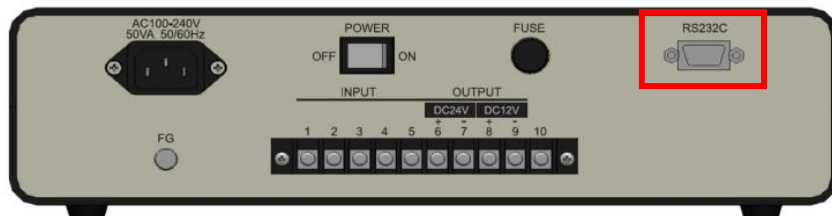

Figure 5-5. RS-232C Connection

6. Software

This software is exclusively used for measuring and processing the data acquired by MS-711N and MS-712. It is used to measure and analyze data.

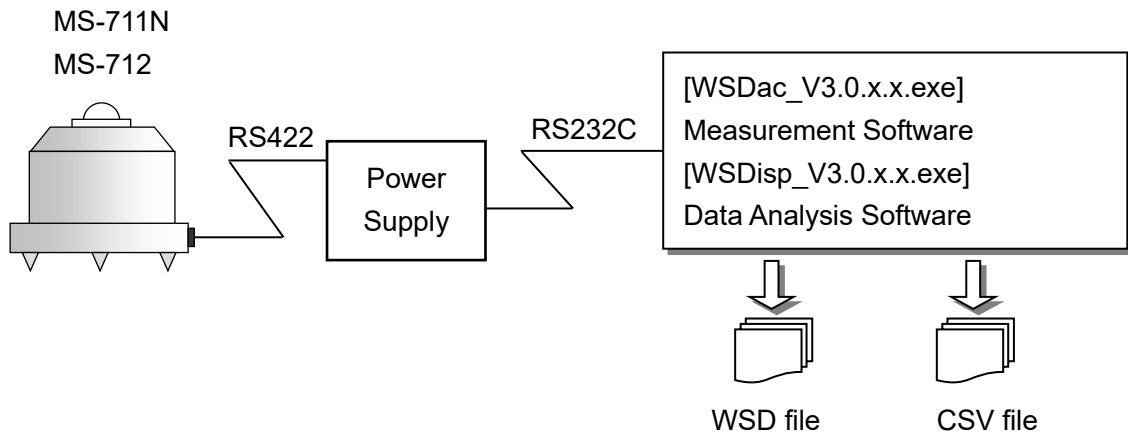

Figure 6-1. Outline of Software

6-1. Installation and Uninstallation

1. Installation

NOTE: Make sure to install the software on a PC which has administrative and/or installation authority.

- 1) Power ON the PC and insert the installation disk to the CD disk drive while the Windows desktop screen is displayed.
- 2) The install disk is included in the CD-ROM labeled as "Spectroradiometer MS-711N". The separate software for the measurement software and data analysis are included in this CD-ROM.
To install measurement software (WSDac_V3.0.x.x.exe), click [WSDac_Software_Ver.3.0.x.x_Installer] → [English] → [Setup.exe] and start the installer.
- 3) Installation Wizard window appears. To go to the next step, click [Next].



Figure 6-2. Installation Wizard Startup Window

- 4) "License Agreement" window appears; select "I accept the terms in the license agreement" then click [Next] button to go to the next step.

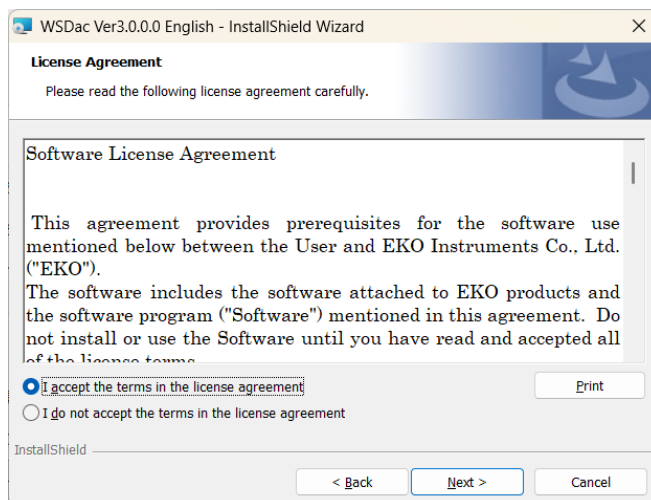

Figure 6-3. License Agreement Window

- 5) "Destination Folder" window appears. If the software will be installed in the "C:\EKO" folder, click [Next] button to go to the next step. To change the destination folder, click [Change...] button and select the appropriate folder.

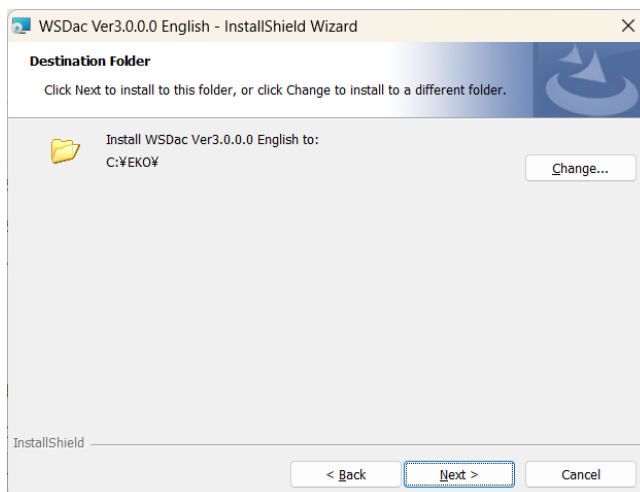

Figure 6-4. Destination Folder Window

NOTE: If the Operation System for the installing PC is either one of the Windows Vista, 7, or 8 and to change the destination folder, UAC (User Account Control) function will be effective, and it will need special attention. Installing and/or data uploading in the folder which OS is restricting the access authority may generate problems. There are "C:\Program Files", "C:\ProgramData", "C:\Windows", and system drive route folder "C:\\" for such folder with restrictions. Avoid these folders when changing the destination folder.

- 6) "Ready to Install the Program" window appears. Confirm the destination folder and if okay, click [Install] button to go to next step.

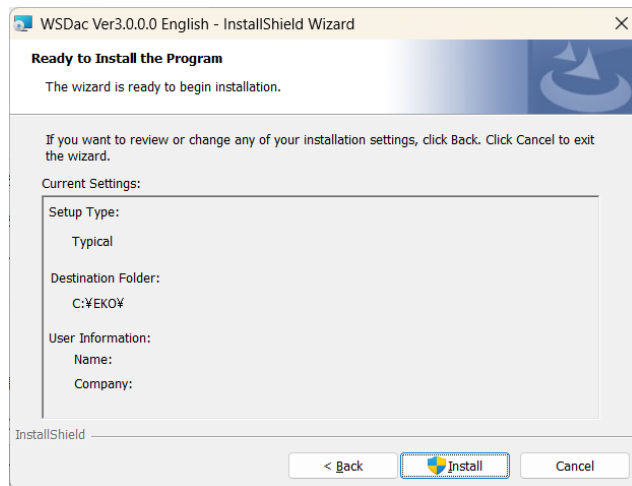

Figure 6-5. Install Window

- 7) After a while, the PC display goes dark and "User Account Control" dialog window appears. Click [Yes] button to start the software installation.

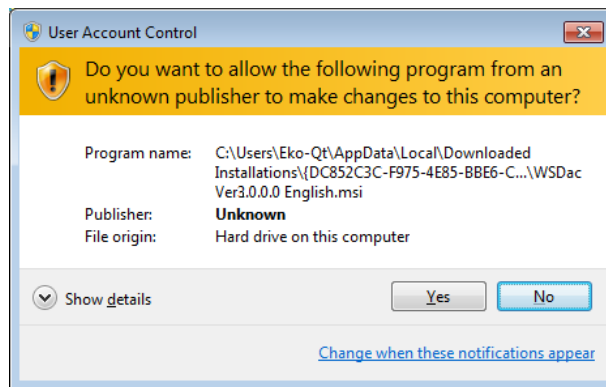

Figure 6-6. User Account Control Window

- 8) As the installation is completed, the following window appears. Click [Finish] button to close the installation window.



Figure 6-7. Installation Complete Window

- 9) When the installation is completed, a shortcut icon as shown below will be created on the desktop, as well as in the Start Menu, “All Programs” → “EKO” → “WISER” → “WSDac_Ver3.0.x.x”.

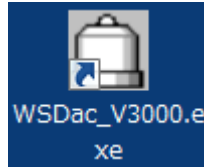

Figure 6-8. “WSDac_Ver3.0.x.x2” Shortcut Icon

- 10) To install the Data Analysis software (WSDisp_V3.0.x.x.exe), click the “Setup.exe” included in the installation disk “WSDisp_Software_Ver3.0.x.x_Installer” → “English” to start the installer. The installation wizard will start; follow the wizard which steps are in the similar procedure as the measurement software.

Once the software installation is completed, following shortcut icon will be created for Data Analysis software.

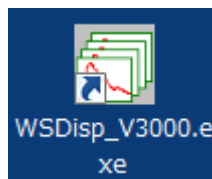

Figure 6-9. “WSDisp_Software_Ver3.0.x.x” Shortcut Icon

2. Uninstallation

There are 2 ways to uninstall the software.

- 1) Uninstalling from the “Settings”

Access by clicking “Settings” → “Apps” → “Installed apps”. Click the [...] on the right side of the program you want to remove, then select [Uninstall].

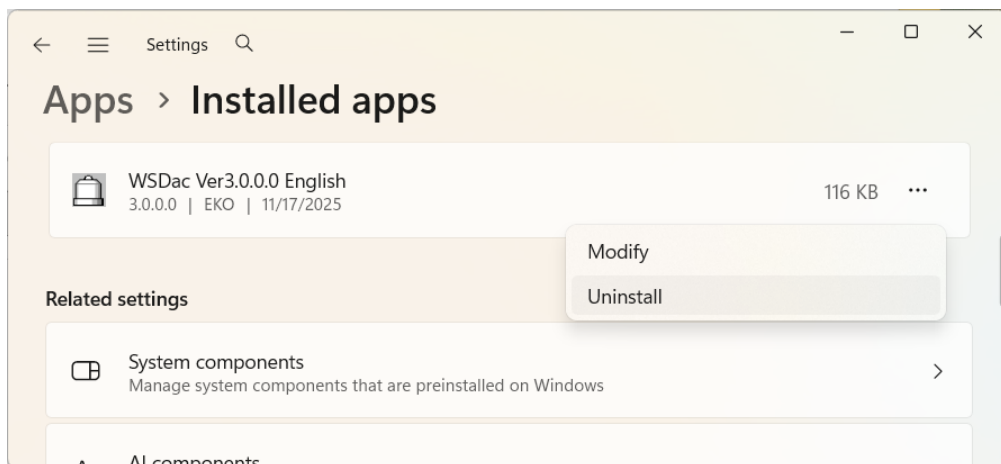

Figure 6-10. Uninstalling from “Programs and Features”

Following message appears; to uninstall, click [Yes] button. The software will disappear from the “Programs and Features” list and confirms the software has been uninstalled.

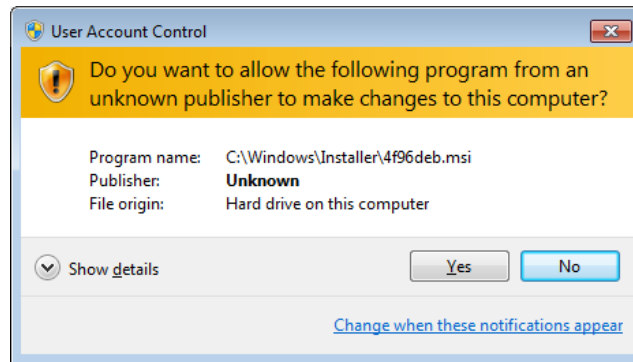

Figure 6-11. User Account Control Window

2) Uninstalling from Installation Disk

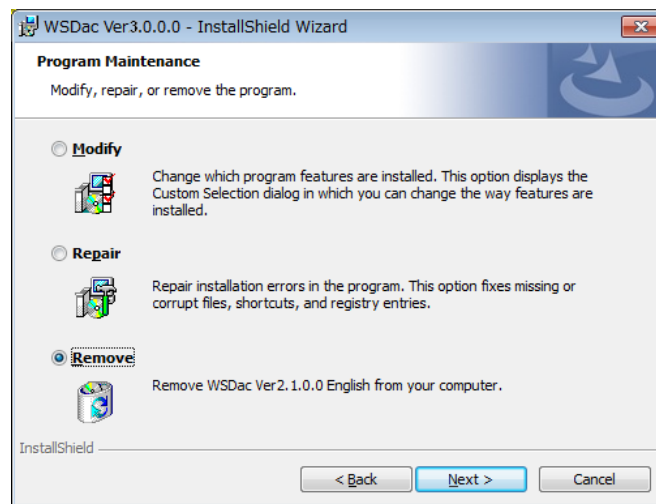

Figure 6-12. Uninstalling from CD-ROM

Just like when the software was installed, startup the software to be uninstalled from the CD-ROM. Proceed according to the messages appear on the window. If the software is already installed, there appear the options as “Modify”, “Repair” and “Remove”. Select “Remove” from this window and click [Next] button. Follow the messages on each step will result in uninstalling the software.

6-2. Data File Format

The following data file formats are available for this software.

Table 6-1. File Format

	File format	Binary/ASCII	Wavelength increment
a	ESM file	Binary	Specified as spectroradiometers
b	CSV file	ASCII	Specified as spectroradiometers
c			1nm interval

1. WSD File (Binary Data)

WSD format data file is composed as binary data. Only the spectral radiation data of the wavelength interval according to spectroradiometers specifications is saved in WSD file.

2. CSV File (ASCII)

CSV file is composed as ASCII format data. The spectral radiation data of wavelength interval according to the spectroradiometers specification can be saved in CSV file, as well as the as well as the spectral radiation data which wavelength interval sampled at 1nm. The CSV file data is easily converted to other formats, including Microsoft Excel.

[Measured Value of CSV Data File and Calculated Value of CSV Data File]

This software can save the CSV data file of measured value which radiation is output for each wavelength, as well as the CSV data file of calculated value which output the calculation result.

[Measured Value of CSV Data File]

Radiation data of each wavelength is saved. This file contains the instrument data (MS-711N, MS-712, or Merge) which is selected ahead of time. See "CSV Format Data" in section "7-2 Before Starting Measurements"

Table 6-2. Example of Measurement Value of CSV Output (Original Wavelength Pitch):

Common for WSDac and WSDisp				
Data	2010/5/8			2010/5/8
Time	7:00:00			7:01:00
Memo	EKO WISER			
Sensor	MS711	MS712	MERGE	MS711
Exposure Time(msec)	5000	1000		5000
Sensor Temp.(deg)	25	21.4		24.7
Power[V]	5.9	5		5.9
Wavelength (nm)	Irradiance (W/m ² /um)	Irradiance (W/m ² /um)	Irradiance (W/m ² /um)	Irradiance (W/m ² /um)
	900.97	37.45		41.48
	901		243.9	41.62
	901.76	38.41		45.63
	902.54	38.34		48.77
	902.94		243.27	50.9
				902.94

Measured Wavelengths	MS-711N Radiation Data	MS-712 Radiation Data	Merged Radiation Data	Data acquired in one time measurement (Marked Blue)
----------------------	------------------------	-----------------------	-----------------------	---

[Calculated Value of CSV Data File]

The calculated value of CSV data file can be saved with data such as PAR (Photosynthetically Active Radiation), PPF (Photosynthetic Photon Flux Density), ILLUMINANCE, Integral (interval integrated value) that are calculated out from the data in each calculated intervals. The PAR/PPFD are calculated from the data between 400~700nm and Illuminance is calculated by multiplying the standard relative luminosity curve to the data between 380 and 780nm. Integral (interval integrated value) will be the integrated value in the specified wavelength interval. Either one will be the calculation result of data which was linearly interpolated with 1nm pitch.

Table 6-3. Example of Calculated Value CSV Output, only WSDisp

2010/5/8				
Time	PAR(W/m ²)	PPFD(umol/m ² /s)	ILLUMINANCE(lx)	Integral[300-1800](W/m ²)
7:00:00	25.49	117.8	5935.9	138.2
7:01:00	25.5	117.8	5937.1	139.5
7:02:00	25.46	117.7	5931.2	131.7

Measured Date & Time	PAR Data	PPFD Data	ILLUMINANCE Data	Radiation Integrated Data
----------------------	----------	-----------	------------------	---------------------------

7. Measurement Software (WSDac)

WSDac.exe is measurement software, and it has main function of data measurement, including the scheduled measurement.

Scheduled measurement takes measurement automatically repeated daily at a certain time frame and in time interval which are setup in advance then save the data in WSD file. In each data measurement, the most appropriate exposure time is automatically setup by the software and takes and save the spectrum data.

NOTE: When taking measurements by switching multiple units of MS-711N/MS-712 on one computer, make sure to do the following:

- Restart the software each time the instrument is switched. If the software is not restarted, the calibration value saved from the previous measurements will be used, and the measurement will not be accurate.
- Change the folder for saving. With this software, the multiple data of the same model type instrument cannot be saved in a same folder.

7-1. Starting Measurement Software WSDac

As the “WSDacV3.0.x.x.exe” is started, the Fig.7-1 Window is displayed.

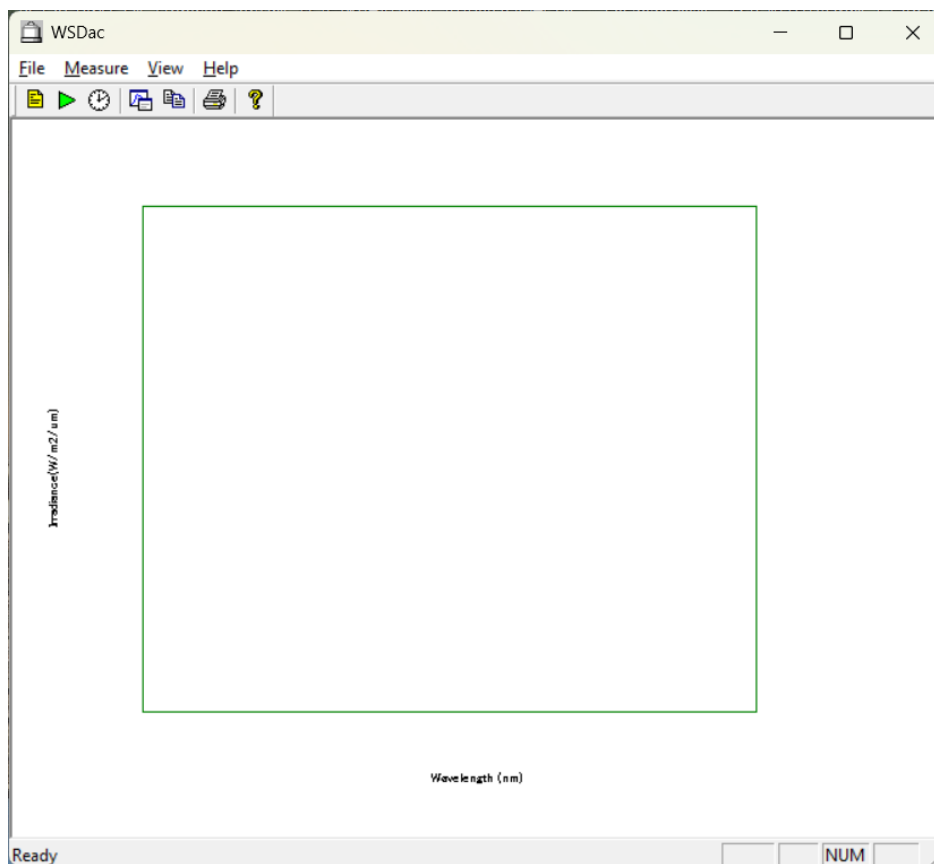

Figure 7-1. WSDac.exe Main Window

7-2. Before Starting Measurement

Before starting the measurement, setup the measurement condition. Go to [Measure → Measurement Settings] from the tool bar or click the [Configuration] button located at the top (Figure 7-2) then the [Measurement Settings] window will be displayed as shown on Figure 7-3.

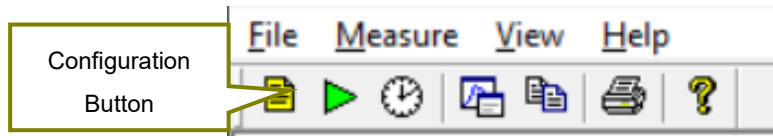

Figure 7-2. Configuration Button

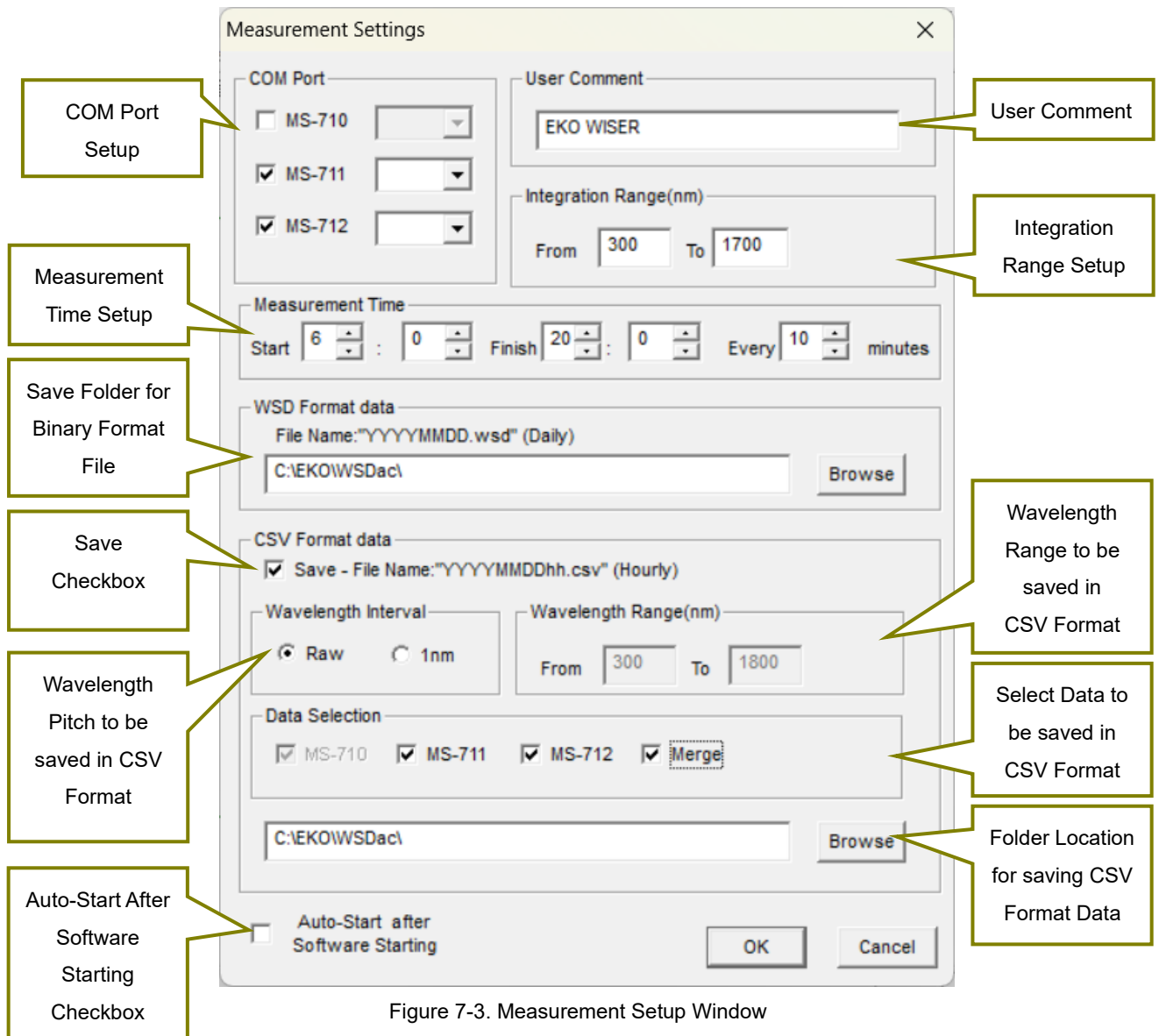

Figure 7-3. Measurement Setup Window

Table 7-1. Measurement Setup Window Functions

Functions	Description
[COM Port Setup]	Select a COM Port which is connected to the instrument to be controlled.
[User Comment]	Save the measurement data with attached memo which is entered in this box.
[Integration Range]	Indicates the specified integration value interval on the measurement data graph window.
[Measurement Time]	Measurement will be taken in the specified interval during the measurement start time to the end time.
[WSD Format Data]	A folder can be selected to save the Binary format spectrum data. Click [Browse] button to select a folder for data to be saved. When the data is taken, the file name will be saved with the measured date [YYYYMMDD.WSD] (YYYY: Year, MM: Month, and DD: Day)
[CSV Format Data]	A folder can be selected to save the CSV format spectrum data.
[Save] Checkbox	By checking this checkbox, measurement data in each time interval are saved in CSV format file. The file name will be the date and time of the measurement, such as [YYYYMMDDhh.WSD] (YYYY: Year, MM: Month, DD: Day, and hh: Time).
Wavelength Pitch	By selecting the "Raw", the data is saved with the unique wavelength pitch of the instrument itself. By selecting "1nm", the data is saved as linearly interpolated in 1nm pitch.
Wavelength Range	The data will be saved in CSV format data in the wavelength range which is specified; this is effective only when the Wavelength Pitch is setup with "1nm".
Data Selection	Saves the data of the instrument which is selected. When measuring the MS-711N and MS-712 at the same time, the combined data of MS-711N and MS-712 can be saved by selecting "Merge."
Folder for Saving CSV Format Data	Click [Browse] button to specify the folder for data to be saved. For CSV format file will create a Year folder [YYYY] automatically under the specified folder to save the data.
[Auto-Start After Software Starting]	By checking the checkbox, the measurement will be automatically started as the software is started up with the condition setup in the last measurement condition. When clicking [OK] button shown at the bottom of the window, the data save folder setup is completed.

7-3. Start Measurement

There are Manual Measurement, which takes just one measurement, and Interval Measurement, which takes measurement by specified interval.

To start a manual measurement, go to [Measure → Start Manual Measurement] from the tool bar or click the [Manual Measurement Start] button located at the top (Figure 7-4); the [Manual Measurement Running] window is displayed as shown on the Figure 7-5.

To start Interval Measurement, go to [Measure → Start Interval Measurement] from the tool bar or click the [Start] button (Figure 7-6) located at the top; the [Interval Measurement] window is displayed as shown on Figure 7-7.

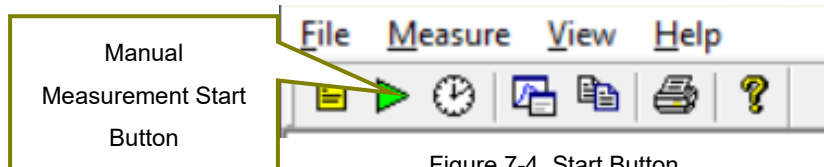

Figure 7-4. Start Button

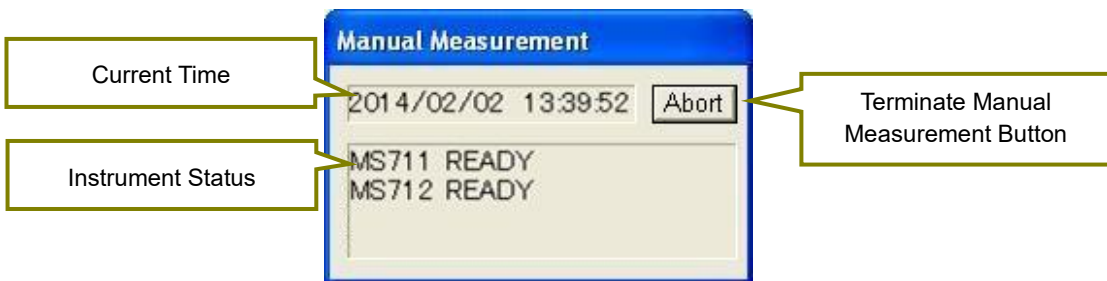

Figure 7-5. Interval Measurement Window

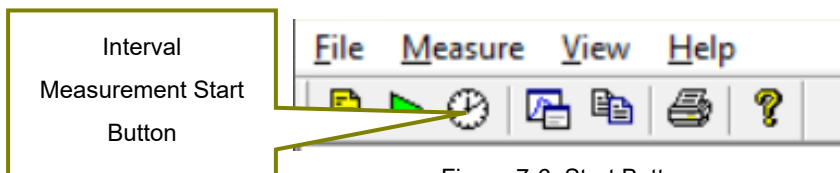

Figure 7-6. Start Button

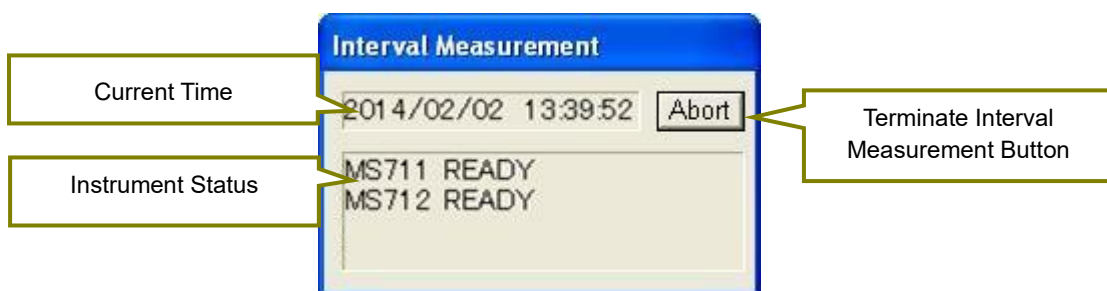

Figure 7-7. Interval Measurement Window

- [Current Time]: The current time is displayed.
- [Instrument Status]: The statuses of the measuring instruments are displayed. The Table 7-2 describes the meaning of each message and status, and how to deal with the statuses.
- [Abort] Button: Terminates the manual or interval measurement.

Table 7-2. Messages Displayed on the Interval Measurement Dialog Window

Messages	Statuses	Actions
Error (Opening COM Port failed)	Cannot open the setup communication port.	Check the measurement settings.
Getting the sensor information	Software retrieving the sensor information. Normal condition	No action necessary
Error (Communication with the sensor failed)	No responses from the instrument	Check the communication cable and power supply of the instrument.
Error (Getting the sensor information failed)	The communication is unstable.	Check the communication cable for disconnection and cable condition.
Error (Getting the calibration value failed)		
Error (Sensor Name)	A sensor which is different from the setup is connected.	Check the communication port and the corresponding instrument.
READY	Completed the measurement preparation.	No action necessary.
Measuring	Displayed during the measurement is taken.	No action necessary.
Retrying measurement	The measurement failed, but retrying to start measurement.	Check communication cable and power supply of the instrument.
Measurement failed	Displayed when the measurement is retried for 3 times and measurement failed.	
Measurement OK	Measurement was done successfully.	No action necessary.

Application Log File (YYYY(Year).LOG)

The YYYY(Year).LOG file will be created in the same folder where the WSD file, which saving file location was setup for the WSDac Measurement Software, is saved.

This file records the information such as application start-up, measurement start, measurement error, file processing error. (Table 7-3)

Table 7-3. Contents Indicated in Application Log File

Message	Condition
APP START	Measurement Software startup
APP CLOSE	Measurement Software exit
INT.MEAS START	Started Interval Measurement
INT.MEAS STOP	Ended Interval Measurement
ERROR MEAS THREAD CREATE	Internal Error (Measurement Thread startup failed)
ERROR WSD LOAD	Existing WSD file uploading for adding data failed
ERROR MS711 MEAS	MS711N Measurement failed.
ERROR MS712 MEAS	MS712 Measurement failed.
ERROR WSD SAVE	WSD File Saving failed.
ERROR CSV SAVE	CSV File Saving failed.

7-4. Measurement Data Display

By taking a measurement, the Measurement Data display window shows the graph (Fig. 7-8). This graph is updated per each measurement.

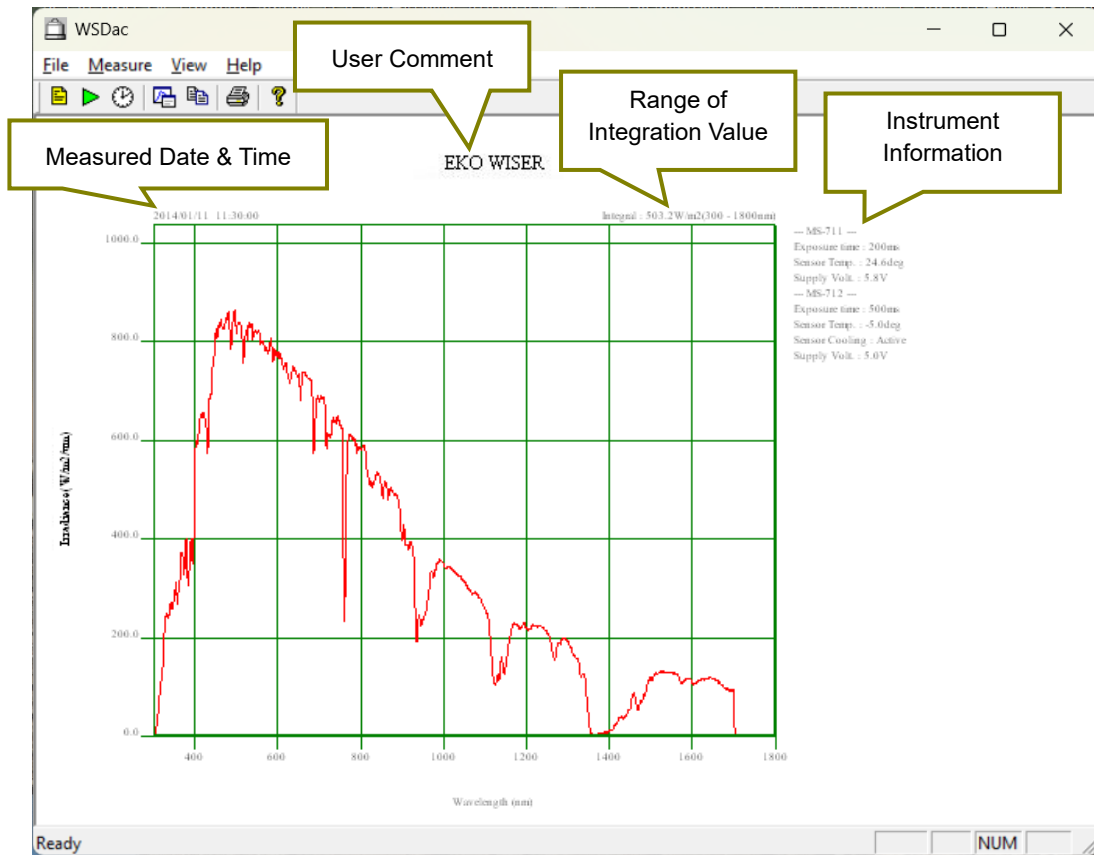

Figure 7-8. Measurement Data Display Window

- [Measured Date & Time]:** The date and time of the displayed measurement taken.
- [User Comment]:** Displays the [User Comment] entered in the Measurement Setting.
- [Range of Integration Value]:** Displays the spectrum radiation integration value (W/m²) within the wavelength range which is setup in [Integration Range] in the Measurement Setting.
- [Instrument Information]:** Displays the information of [Buildup Time (Exposure Time)], [Sensor Temperature], [Power Supply Voltage], and [Sensor Cooler Drive (only MS-712)]

7-5. Graph Setting

When specifying the graph axis and color of line on the displayed graph, use the [Graph] button. Either go to [View → Graph Settings] from the tool bar or click the [Graph] button (Figure 7-9) located at the top, the [Graph Settings] window will display as shown on Figure 7-10.

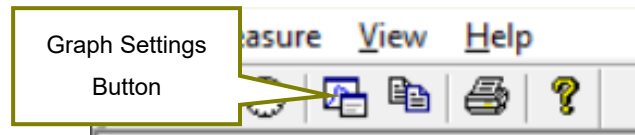

Figure 7-9. Graph Button

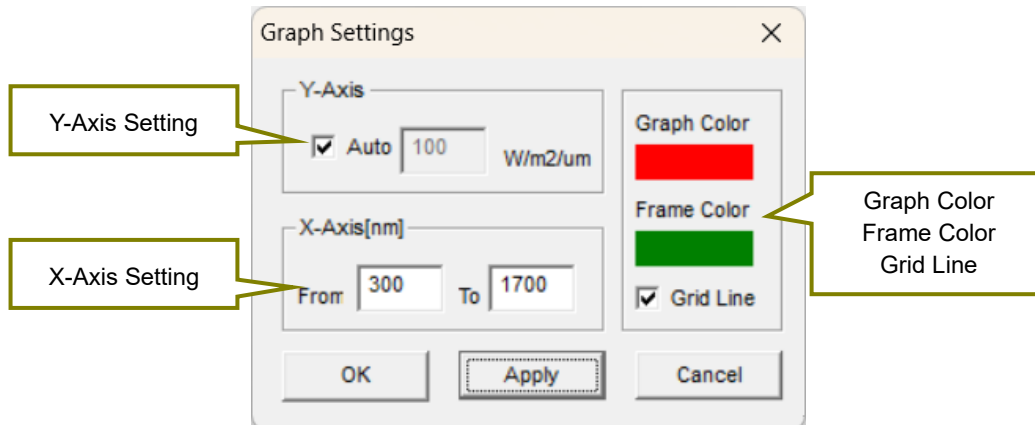

Figure 7-10. Graph Settings Window

- [Y-Axis Setting]:** By checking the “Auto” checkbox, the Y-Axis scale is automatically setup. By removing check from the “Auto” checkbox, the maximum value of Y-Axis can be specified
- [X-Axis Setting]:** Specify the X-Axis wavelength range to be displayed on graph.
- [Graph Color, Frame Color, and Grid Line]:** By clicking the colored area, the color selection dialog window will be displayed, and the graph and frame color can be specified as desired. The grid line of the graph can be shown or not shown by checking or un-checking the [Grid Line] checkbox.
- [OK, Apply, Cancel] Buttons:** By clicking the [OK] button, the Graph Setting window will disappear and go back to the graph display window.
Clicking [Apply] button will allow the user to see the changes on the graph with the Graph Setting window still opened.
[Cancel] button can cancel the setting changes on the Graph Setting.

7-6. Graph Copy

This function copies the graph image displayed on the window on to clip board. Go to [View → Copy] from the tool bar or click the [Copy] button (Figure 7-11) at the top to make copy of the graph.

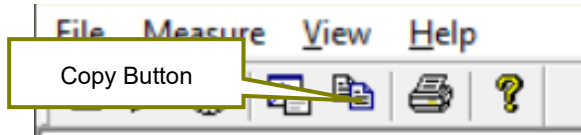

Figure 7-11. Copy Button

7-7. Print

This function prints the graph image displayed on the window. Go to [File → Print] from the tool bar or click the [Print] button (Figure 7-12) at the top to print the graph.

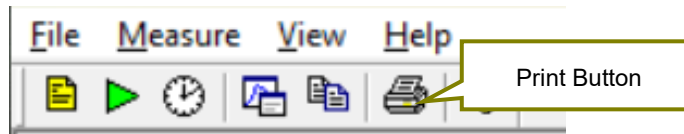

Figure 7-12. Print Button

Also, to see the print preview condition, go to [File → Print Preview] from the tool bar. Printer can be setup from [File → Printer Setup] on the tool bar.

7-8. Version Information

The software version information can be displayed. Go to [Help → About WSDac...] from the tool bar or click the [?] button (Figure 7-13) at the top to see the software version information.

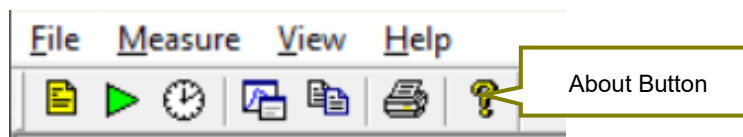

Figure 7-13. About Button

8. Data Analysis Software (WSDisp)

WSDisp.exe is data analysis software, and it has main function to view the measured data (WSD) and save as CSV format files.

8-1. Starting Data Analysis Software WSDisp.exe

As the “WSDisp_V3.0.x.x.exe” is started, the Figure 8-1 Window is displayed.

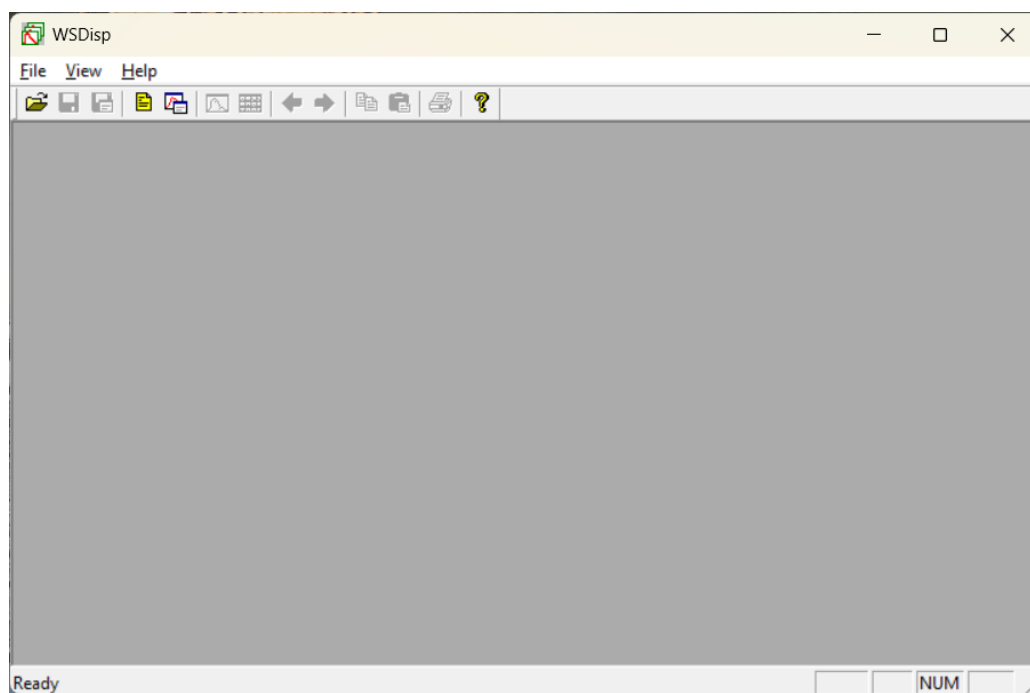

Figure 8-1. WSDips_V3.0.x.x.exe Window

8-2. Display Measurement Data

1. Data Uploading

Open the saved measurement data. To open, go to [File → Open...] from the tool bar or click the [Open] button located at the top of the window (Fig. 8-2). When the file selecting dialog window appears, select a measurement data file (extension: WSD file) and click [Open] button to show the data.



Figure 8-2. Open Button for Measurement Data Files

2. Displaying Data List

After the measurement data is uploaded, "Tiled Data Window" appears as shown on Figure 8-3.

Only on this window, the data can be deleted by selecting data, then right click → Delete.

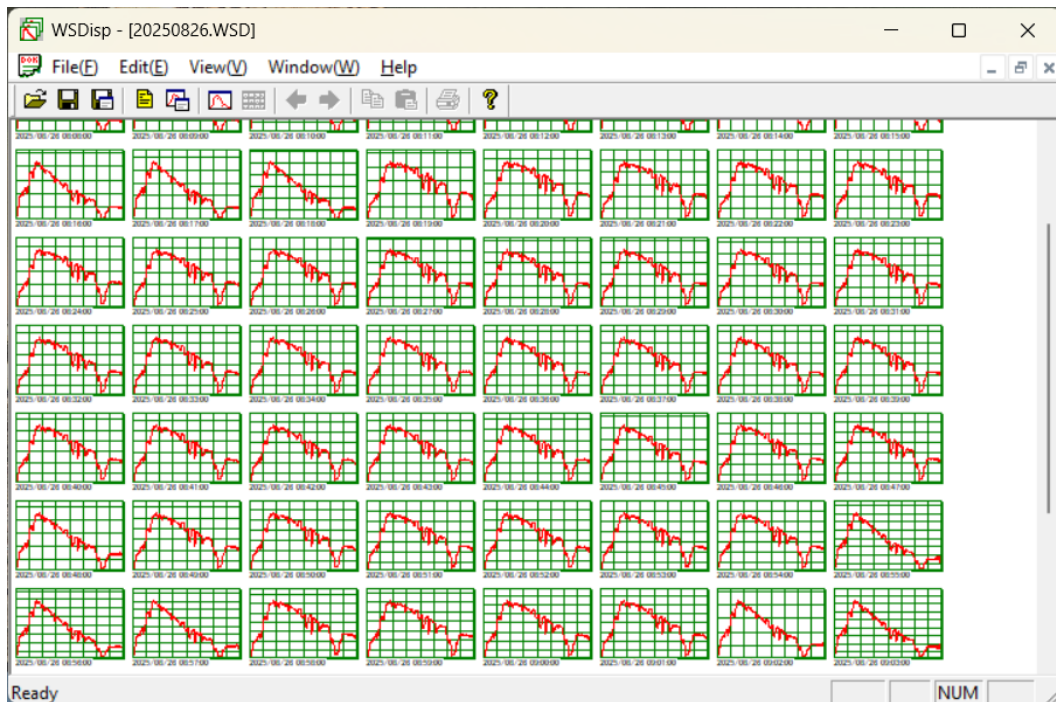

Figure 8-3. Tiled Data Window

3. Viewing Data Details

Double click the data shown on the Tiled Data window, or go to [View → Selected Data] on the tool bar, or clicking the [Selected Data] button (Figure 8-4) will display the “Tiled Data window” as shown on Figure 8-5.



Figure 8-4. Selected Data Button

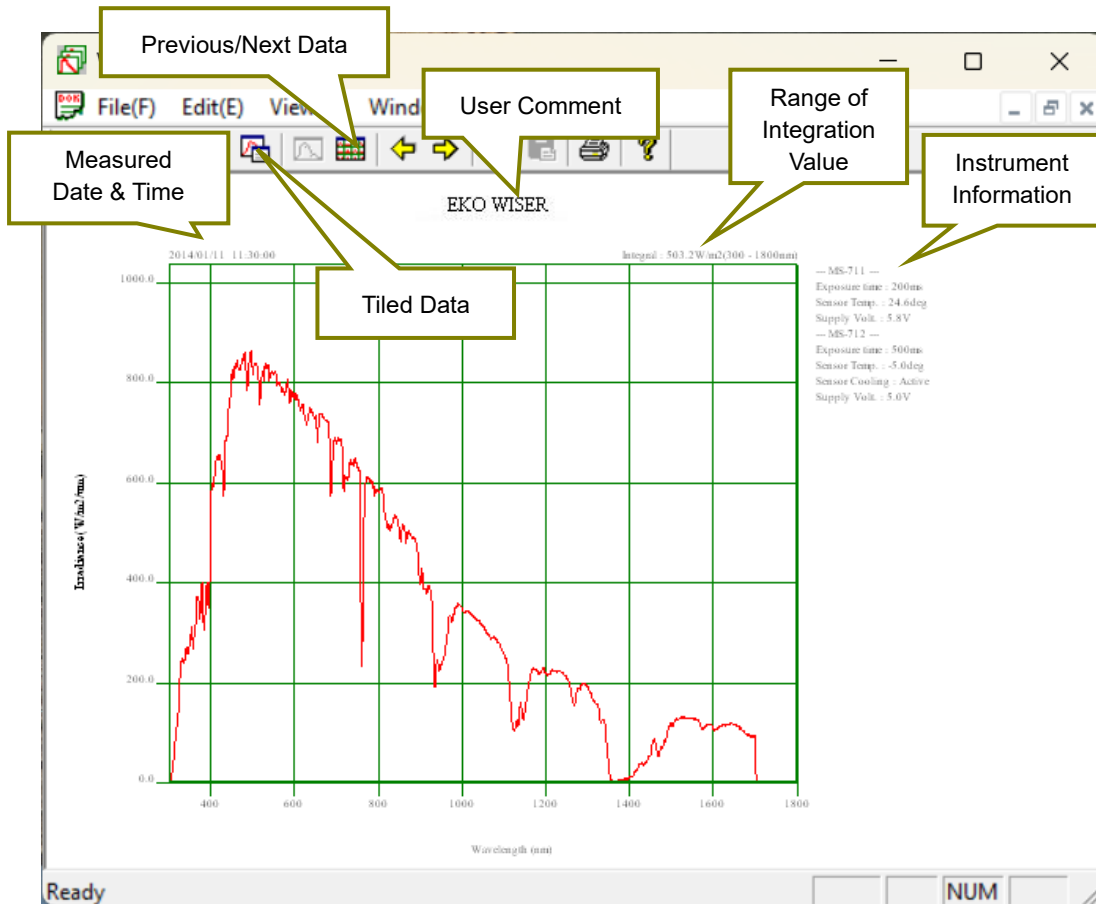

Figure 8-5. Measured Data Details Window

- [Previous/Next Data]:** By clicking these buttons, the data previous or next to the data currently shown is displayed. Arrow keys (←/→) on the keyboard can be also used to for this function.
- [Tile Data]:** The display window can be switched back to the Tiled Data window by clicking this button. Double clicking the displayed graph can also switch to the Tiled Data window.
- [Measured Date & Time]:** The date and time of the displayed measurement taken.
- [User Comment]:** Displays the [User Comment] entered in the Measurement Setting.
- [Range of Integration Value]:** Displays the spectrum intensity integration value (W/m²) within the wavelength range which is setup in [Integration Range] in the Measurement Setting.
- [Instrument Information]:** Displays the information of [Buildup Time (Exposure Time)], [Sensor Temperature], [Power Supply Voltage], and [Sensor Cooled Drive (only MS-712)]

4. Displaying Specific Wavelength Data

Left clicking the mouse on the graph displayed on the graph displaying window, a cross-cursor appears as shown on Figure 8-6, and the value of the point where cross-cursor intersection is located is displayed on the right bottom of the graph. The cross-cursor moves as left clicking and moving the mouse; the values of each intersection position are shown at the right bottom of the graph.

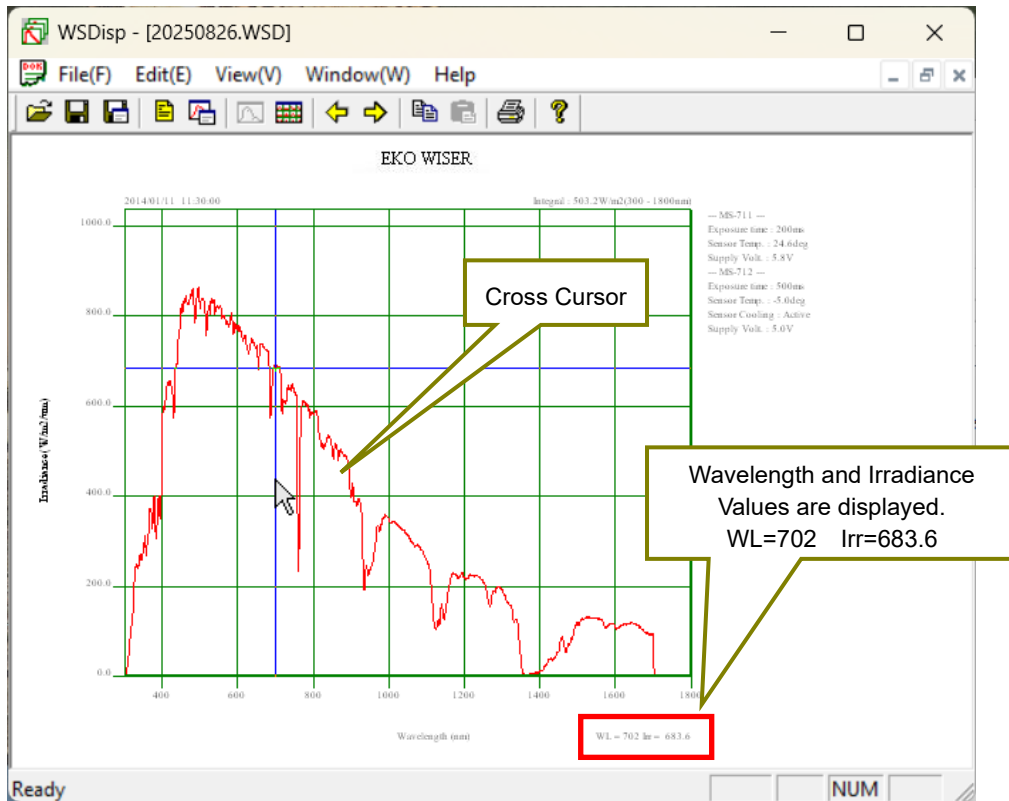

Figure 8-6. Displaying Specific Value on Graph

5. Displaying Multiple Selected Data

When selecting multiple data in a sequential range, first left click the first data in the range then as pressing the [Shift] key, click the last data in the range. The data can be selected as shown on the Figure 8-7. Also, by using [Ctrl] key, the desired multiple data can be selected.

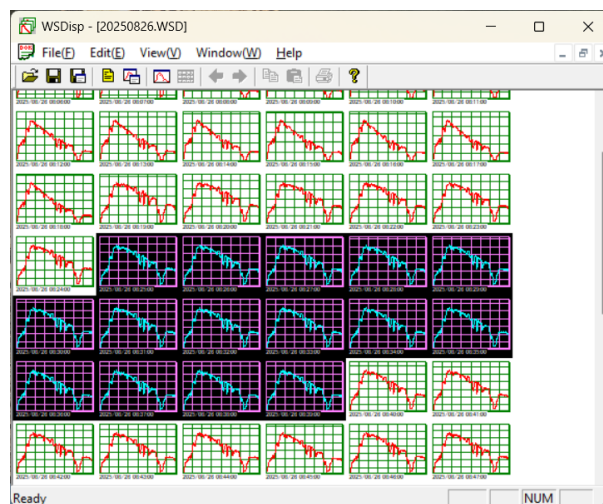

Figure 8-7. Selecting Multiple Data

As the multiple data are selected, right click the mouse and select [Spectral Data] from the dropdown list. The data are displayed in superimposed condition as shown on Figure 8-8.

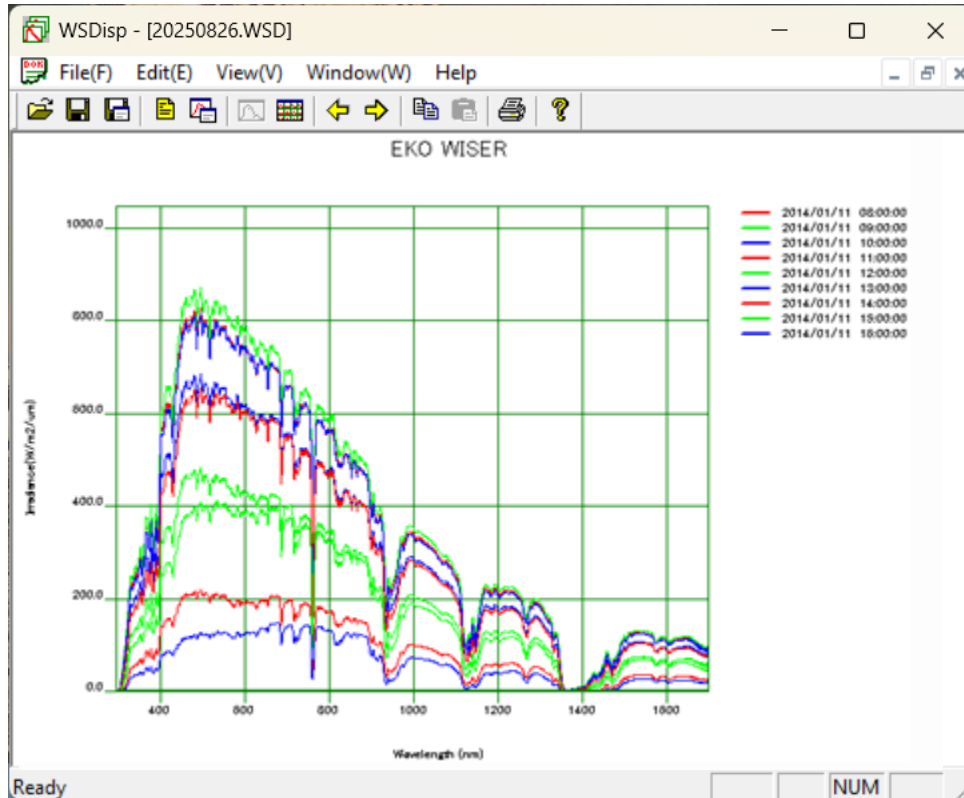

Figure 8-8. Superimposed Graph for Displaying Multiple Data

There are 10 colors for graphing: Red, Orange, Yellow, Yellow Green, Green, Light Green, Light Blue, Blue, Navy and Purple, registered as default colors. If more than 10 data are selected, the colors are repeated.

Graph colors can be freely changed by opening the WSDisp_V3.0.x.x.ini file as text editor and editing each RGB values of the [COLOR TABLE]. Also, by adding the number of lines, more than 10 colors can be registered.

WSDisp_V3.0.x.x.ini File

```

:
[COLOR_TABLE]
#LINE_COLOR001=R,G,B
LINE_COLOR001=255,0,0
LINE_COLOR002=255,94,25
LINE_COLOR003=251,236,53
LINE_COLOR004=128,255,0
LINE_COLOR005=0,255,0
LINE_COLOR006=0,255,128
LINE_COLOR007=0,255,255
LINE_COLOR008=0,128,255
LINE_COLOR009=0,0,255
LINE_COLOR010=128,0,255

```

6. Deleting Data

The data can be deleted on the tiled data list window by selecting data → right click → delete.

However, the data will not be completely deleted from the WSD file just by this procedure. In order to delete the original data, it is required to select “Save” from the File menu. Note that the original data will not recover by overwriting the file to save. If the original data is an important data, it is recommended to select “Save as...” to save with different name.

8-3. Data Setting

In order to setup the range or pitch of wavelength for saving data in CSV format, contents of the data to be saved, or setup the integration range, click the [Data Settings] button. Go to [File → CSV Settings] from the tool bar or click the [Start] button (Figure 8-9) located at the top then the [CSV Settings] window is displayed as shown on Figure 8-10.



Figure 8-9. Data Setting Button

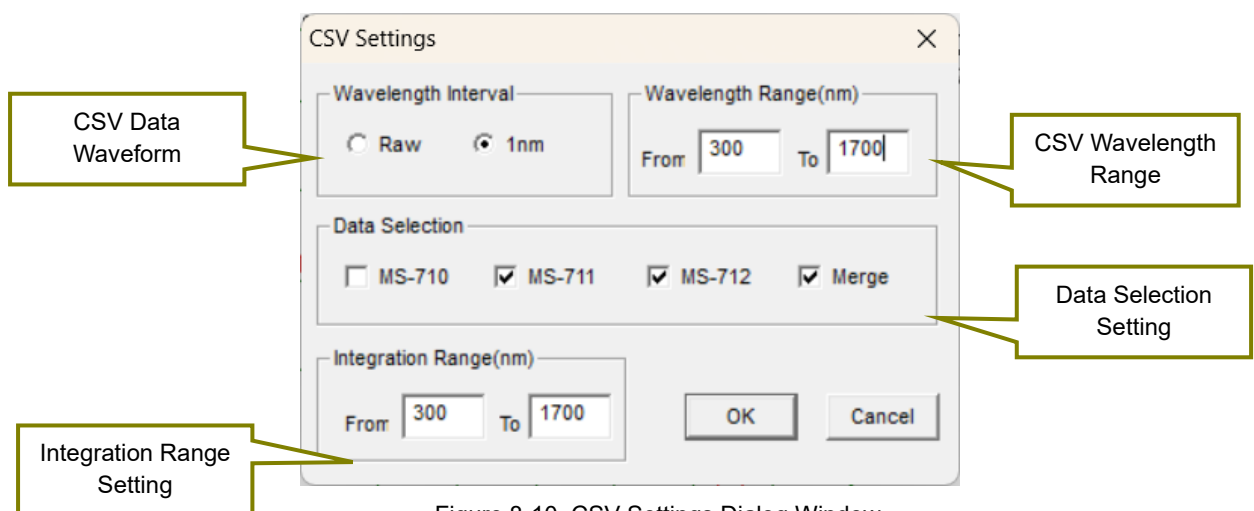

Figure 8-10. CSV Settings Dialog Window

- [CSV Data Waveform]:** Specify the wavelength pitch for when the [Saving Measurement Value in CSV Format]. By selecting the “Raw”, the data is saved with the unique wavelength pitch of the instrument itself. By selecting “1nm”, the data is saved as linearly interpolated in 1nm pitch.
- [CSV Wavelength Range (nm)]:** Specify the wavelength range for [Saving Measurement Value in CSV Format]; this is effective only when the Wavelength Pitch is setup with “1nm”.
- [Data Selection]:** Saves the data of the instrument which is selected for [Saving Measurement Value in CSV Format]. When measuring the MS-711N and MS-712 at the same time, the combined data of MS-711N and MS-712 can be saved by selecting “Merge.”
- [Integration Range]:** Specify the integration range for [Saving Measurement Value in CSV Format]. Also display the specified range of integrated value on the Selected Data display window, and the range becomes the integrated value of the saving CSV calculated value.

8-4. Graph Setting

When specifying the graph axis and color of line on the displayed graph, click the [Graph] button. Go to [View → Graph Settings] from the tool bar or click the [Graph] button (Figure 8-11) located at the top then the [Graph Settings] window will display as shown on Figure 8-12.



Figure 8-11. Graph Button

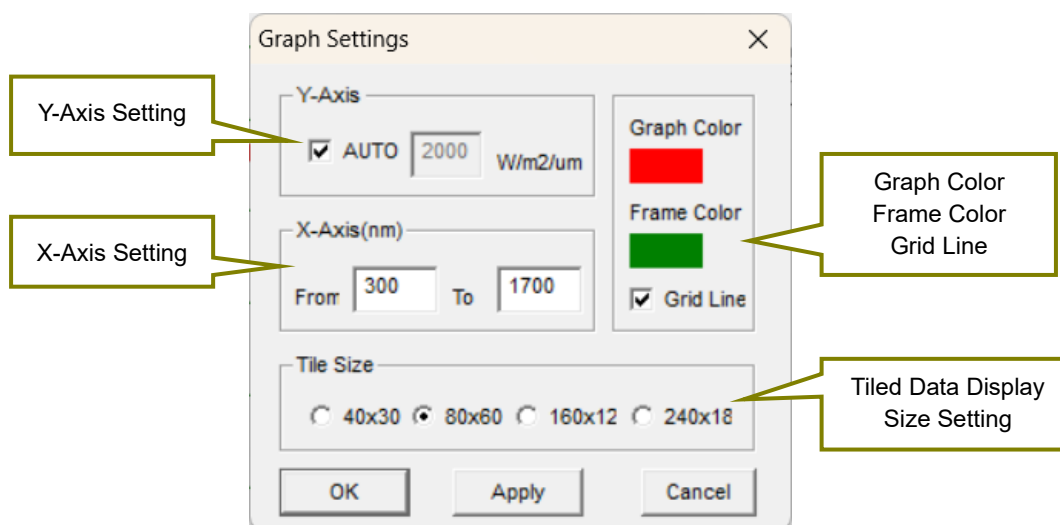

Figure. 8-12. Graph Settings Window

- [Y-Axis Setting]:** By checking the "Auto" checkbox, the Y-Axis scale is automatically setup. By removing check from the "Auto" checkbox, the maximum value of Y-Axis can be specified
- [X-Axis Setting]:** Specify the X-Axis wavelength range to be displayed on graph.
- [Graph Color, Frame Color, and Grid Line]:** By clicking the colored area, the color selection dialog window will be displayed, and the graph and frame color can be specified as desired. The grid line of the graph can be shown or not shown by checking or un-checking the [Grid Line] checkbox.
- [Tiled Data Display Size Setting]:** Setup the size of the one measurement data to be displayed on the Tiled Data display window.
- [OK, Apply, Cancel] Buttons:** By clicking the [OK] button, the Graph Setting window will disappear and go back to the graph display window.
Clicking [Apply] button will allow the user to see the changes on the graph with the Graph Setting window still opened.
[Cancel] button can cancel the setting changes on the Graph Setting.

8-5. Data Saving

To save one or more measured data (WSD Format), to save desired measured data or calculated data in CSV format, either go to [File] (Figure 8-13) in toolbar or use the [Save] button at the top (Figure 8-14).

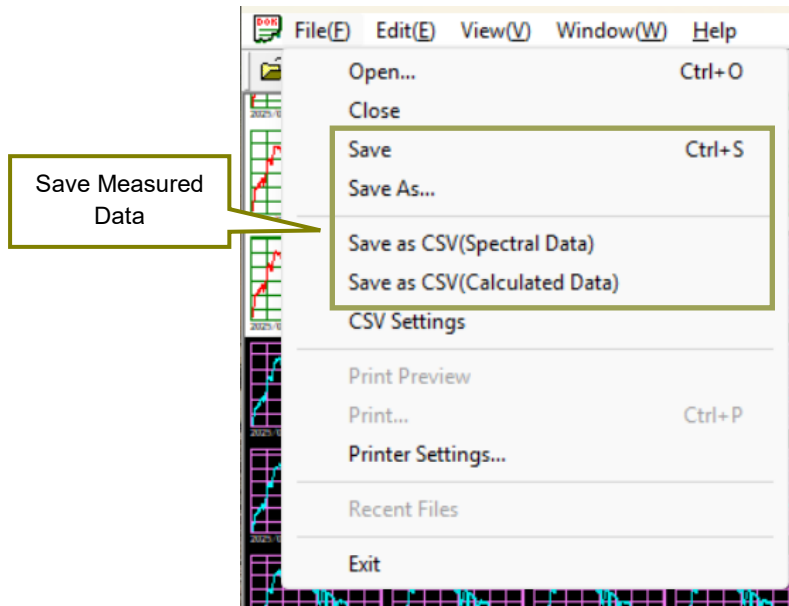

Figure 8-13. Data Saving from Toolbar

- | | |
|---|--|
| [Save]: | Save the measured data (WSD Format) with same name as the original file name. |
| [Save As...]: | Save the measured data (WSD Format) with different name as the original file. |
| [Save Measured Value as CSV Format]: | Save the measured time, comment, data comment, sensor type, exposure time, applied voltage on sensor, and spectrum data per specified wavelength pitch of the selected measurement data in CSV format. |
| [Save Calculated Value as CSV Format]: | Save the data of PAR (W/m^2), PPFD ($\mu mol/m^2/s$), ILLUMINANCE (lx), and integral (W/m^2) per each measured time of the selected measurement data in CSV format. |

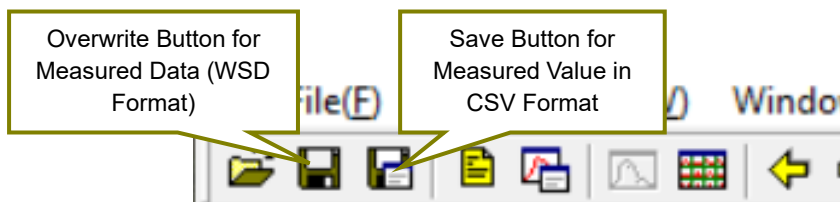

Figure 8-14. Save from the Icons

- | | |
|--|--|
| [Save Measurement Data]: | Save the measurement data (WSD format file) with same name as the original file name. |
| [Save Measurement Value as CSV Format]: | Save the measured time, comment, data comment, sensor type, exposure time, applied voltage on sensor, and spectrum data per specified wavelength pitch of the selected measurement data in CSV format. |

NOTE: If the CSV converted data is lined more than 256, error message may appear when the file is opened, depending on the spreadsheet software type. If such error message appears, convert into CSV when there are less than 256 data lines.

8-6. Graph Copy

The image of the displayed graph can be copied on the clipboard. Go to [View → Copy] from the toolbar or click the [Copy] button (Fig. 8-15) at the top.

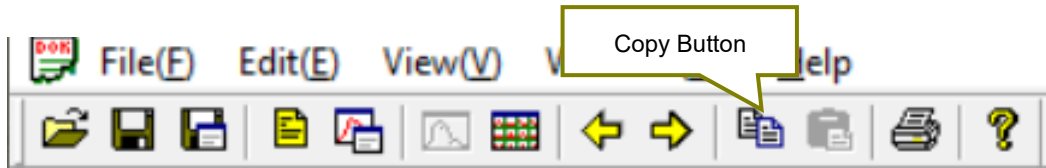

Figure 8-15. Copy Button

8-7. Print

This function prints the graph image displayed on the window. Go to [File → Print] from the tool bar or click the [Print] button (Fig. 8-16) at the top to print the graph.

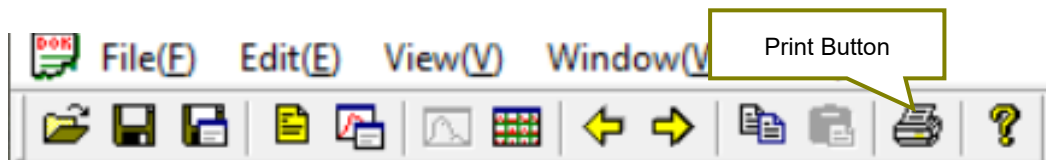

Figure 8-16. Print Button

Also, to see the print preview condition, go to [File → Print Preview] from the tool bar. Printer can be setup from [File → Printer Setup] on the tool bar.

8-8. Version Information

The software version information can be displayed. Go to [Help → About WSDisp...] from the tool bar or click the [?] button (Fig. 8-17) at the top to see the software version information.



Figure 8-17. About Button

9. Measurement Principle

9-1. Measurement Principle

Block diagram of the Spectroradiometers MS-711N/MS-712 is as follows:

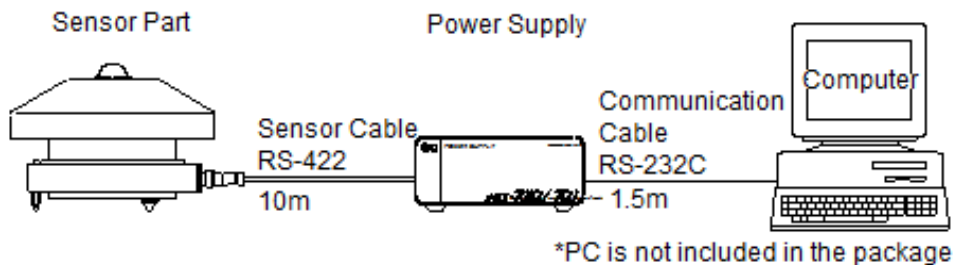

Figure 9-1. Block Diagram

MS-711N/MS-712 sensor part consists of components, such as a dome, a diffuser, a shutter to measure the dark current, a grating with diode array to disperse the light, Peltier element to control temperature, and print circuit board. (See below diagram)

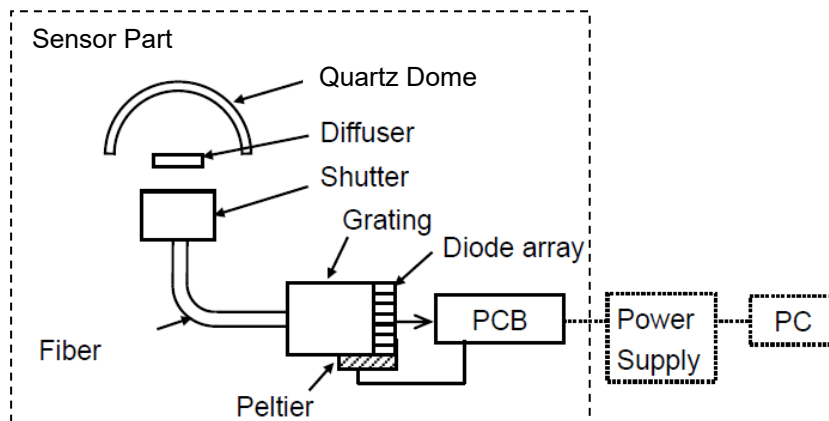

Figure 9-2. Internal Configuration of the Sensor Part

10. Maintenance & Troubleshooting

10-1. Maintenance

To maintain accurate measurement, it is recommended to check and do the following:

Table 10-1. Maintenance

Maintenance Item	Frequency	How To	Effect
Clean Quartz Dome	Several times per week	Remove soil from the quartz dome with air blower or soft cloth and water.	Transmittance will change and sensitivity decreases when the quartz dome is soiled.
Check Glass Dome Condition	Weekly	Check for any crack or scratches on the glass dome.	May lead to water leakage inside the sensor and cause damages to the sensor.
Check Sensor Horizontal Position	Weekly	Adjust the spirit level on the sensor to keep it in horizontal position.	If the sensor level is not in horizontal position, measurements will be inaccurate by affecting cosine/azimuth response.
Check Cable Condition	Weekly	Check the condition of sensor and communication cables, making sure they are connected properly, and they do not have any excess tensions	A disconnected cable may cause abnormal measurement values and operation mistakes. Damaged cables may also have risks of noise or electric shock.
Check Sensor Fixing	Weekly	Make sure the sensor is securely fixed on the mounting base.	Sensor may drop and cause damages and/or injury.
Check Silica Gel and Replace	Weekly	Check the color of the silica gel. If the silica gel color changes from blue to pink, replace them. Turn the drying cartridge in anti-clockwise to remove. Replace with new silica gel on a clear day with less humidity.	Moisture gets inside the sensor while it is used for a long period of time. Moisture saturated silica gel will lead to condensation and may cause decrease of output and damage.
Recalibration	Every 2 years	To maintain the best possible measurement accuracy, it is recommended to recalibrate the sensor every 2 years. Contact EKO for more details and requests for a recalibration and maintenance service.	Sensitivity of the sensor changes by aging and may lead to taking inaccurate measurements.

10-2. Calibration Method

It is recommended to recalibrate the instrument once every 1~2 years. For further information about the calibration and recalibration, please contact EKO.

The spectroradiometer is calibrated against a NIST (National Institute of Standards and Technology) traceable tungsten-halogen OL-FEL standard lamp at a distance of 50 cm. The standard lamp has a known spectrum and the absolute irradiance is calibrated at several wavelengths. By measuring the spectroradiometer's detector responsivity in counts as a function of the irradiance at corresponding wavelengths, the sensitivity of each photo diode array pixel is converted into absolute units ($W/m^2/\mu m$).

The calibration function is determined by averaging 10 single measurements, measured separately for several different wavelength intervals each with a fixed exposure time. This is to use optimal output characteristics of the detector. Finally, the calibration function is uploaded to the spectroradiometer firmware for automatic conversion of measured count into absolute units.

The spectroradiometer is provided with a calibration certificate indicating the measurement uncertainty. The combined uncertainty of the calibration function for each wavelength interval is based on individual uncertainties contributed by the standard lamp, calibration set-up and spectroradiometer performance properties.

10-3. Troubleshooting

Check the following items in case of trouble with the instrument. If any questions should remain, contact EKO for further technical support.

Table 10-2. Troubleshooting

Failure	Action
<ul style="list-style-type: none"> - Cannot operate from PC. - The data cannot be acquired. 	<p>The cable connections for PC, power supply, and/or sensor part may be connected incorrectly.</p> <ol style="list-style-type: none"> 1) Check if the connection between PC and power supply, and power supply and sensor. 2) Check if the power of PC and power supply is turned on. 3) Check the fuse which is in the fuse box on the power supply rear panel; make sure it is not blown. If the fuse is blown, replace with the new fuse which is specified on [Table 11-3. Power Supply Specification]. 4) Check if the COM port connected to PC is correct. 5) Reboot the PC and check the communications and see if PC operation recovers successfully. 6) Remove anything which could cause the noise for power supply cable and sensor cable.
<ul style="list-style-type: none"> - The measured value is abnormal - S/N value of acquired data is not good. - Measured value is very low. 	<ol style="list-style-type: none"> 1) Shutter, spectrometer or PCB could be defected. In case there are any damages or malfunctions, please call EKO for assistance 2) If multiple MS-711N/MS-712 are connected to one PC to operate, make sure to restart the software each time the instrument is switched. <p>Check if the dome is clean. Refer to the chapter "Maintenance"</p>
<ul style="list-style-type: none"> - The software is operating abnormal. 	<p>The PC and software could be defected.</p> <p>Reboot the PC then retry the software.</p>

11. Specification

11-1. Sensor Specifications

Table 11-1. Sensor Specification

	MS-711N	MS-711NF (With Ventilator)	MS-712	MS-712F (With Ventilator)
Wavelength	300~1100nm		900~1700nm	
Wavelength Interval	0.3~0.5nm		1.2~2.2nm	
Spectral Resolution	<7nm		<7nm	
Wavelength Accuracy	±0.2nm			
Temperature Dependency	±2%		±5%	
Operating Temperature	-10~ +50°C		-10~ +40°C	
Temperature Control (Ta: Ambient Temperature)	25°C±2°C (Ta = -10~+40°C) 25°C~ 32°C (Ta = +40 ~ +50°C)		Cooling sensor Controlled @ -5°C±0.5°C	
Exposure time	10msec~5000msec, automatically controlled			
Dome material	Synthetic Quartz		BK7	
Communication	RS422 (between sensor and power supply unit)			
Power supply	12VDC	Sensor: 12VDC Ventilator: 100VAC, 50/60Hz	12VDC/5VDC	Sensor: 12VDC, 5VDC Ventilator: 100VAC, 50/60Hz
Maximum Power Consumption	50W	66W	65W	81W
Dimension (Including cover & dome)	240(φ)×197(H) mm	260(φ)×263(H) mm	320(φ)×200(H) mm	320(φ)×270(H) mm
Weight (Sensor Part)	4.5kg	7.8kg	7.5kg	11.3kg

Table 11-2. Definitions of Terms

Terms	Definitions
Wavelength Range	Range of wavelength which can be measured
Wavelength Interval	Interval of wavelength for measuring data
Wavelength Resolution	Full width at half-maximum when emission line is input
Wavelength Accuracy	Accuracy of wavelength
Cosine Response	Difference from the theoretical value (cos θ) at zenith angle of 0°~ 80°
Temperature Dependency	Tolerance of change in output when ambient temperature changes between -10°C~ +50°C.
Exposure Time	Shutter open time. Optimum value is automatically selected in the time between 10msec ~ 5,000msec.

11-2. Power Supply Specification

Table 11-3. Power Supply Specification (Required one for each MS-711N and MS-712)

Items	MS-711N	MS-712
Power supply (Standard)	Input : 100~240V, 50/60Hz Output : 12VDC(50W)	Input : 100~240V, 50/60Hz Output : 12VDC(50W), 5VDC(15W)
Maximum Power Consumption	100W (when DC output 50W)	130W (When DC output 65W)
Fuse	φ5.2x20, 250V, 2A	
Communication	RS232C(between power supply and PC)	
Operating conditions	Temperature: 0~+40°C, Humidity: 0~90%RH *No condensation.	
Dimension	320(W) x 240(D) x 80(H) mm	320(W) x 220(D) x 120(H) mm
Weight	1kg	1kg

11-3. Software

Table 11-4 Software Specifications

	Details
Software Versions	Measurement Software Version: 3.0.x.x Data Analysis Software Version: 3.0.x.x
Applicable OS	Microsoft Windows XP/Vista/7/8/10/11
Operation Environment	CPU: Pentium 1GHz or more Memory: More than 1GB HHD Capacity: More than 20GB Display Resolution: More than 1024 x 768 Interface: RS-232C port Optical Drive: CD-ROM drive
Software Function	Data Measurement (Continuous, free exposure time adjustments) Data Saving (Personalized format, CSV format) Data Graphing (Tiled/Detailed display, Unit conversion) Data Calculation (PAR, PPFD, Illuminance, Integral)

11-4. Cables

Table 11-5 Cable Specifications

Cables	Details	
Sensor Cable	Cable Type:	MVVS
	Diameter:	0.5mm ² x 12pins
	Outer Diameter:	Φ10.4mm
	Cable end	Y Terminal (Model Number)
	Cable Length:	10m

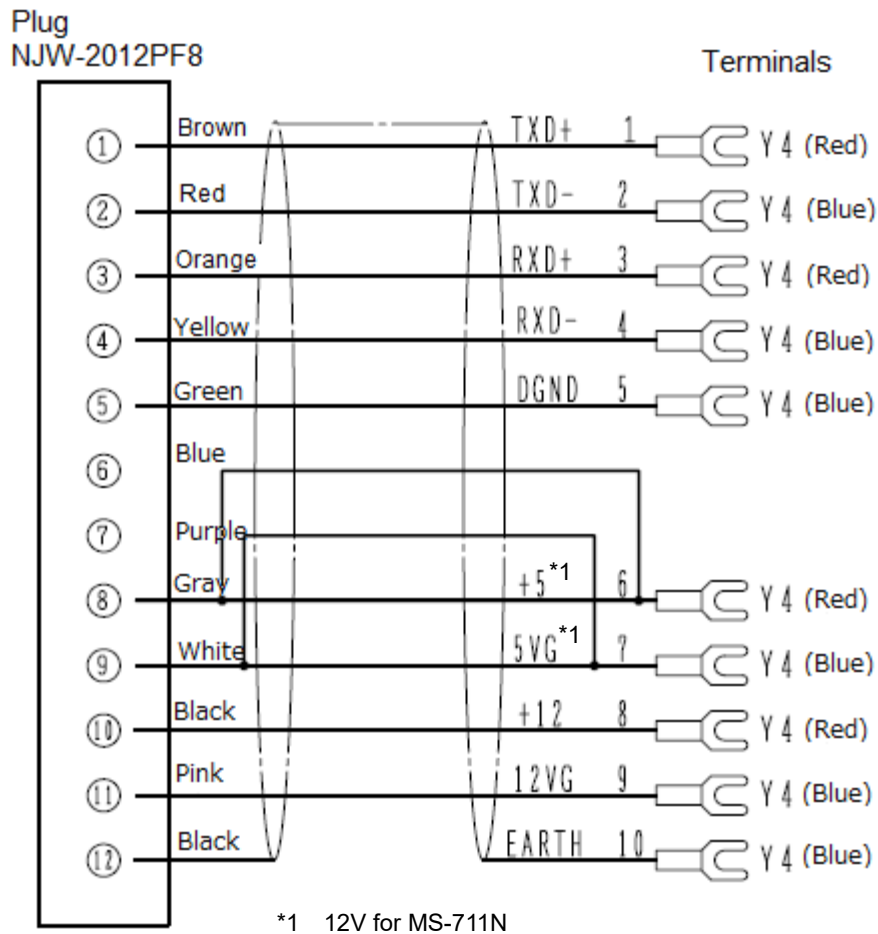

Figure 11-1. Sensor Cable Connections

11-5. Dimensions

1. Sensor Part

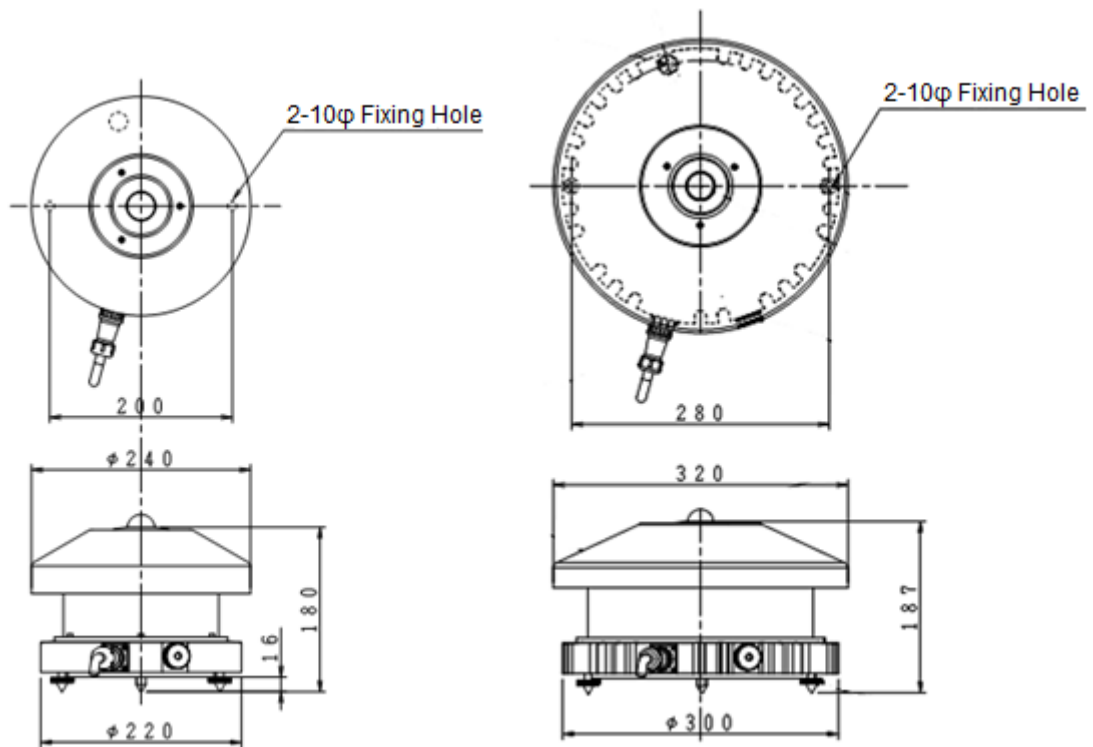

Figure 11-2. Sensor Part Dimensions (Left: MS-711N, Right: MS-712)

2. Power Supply

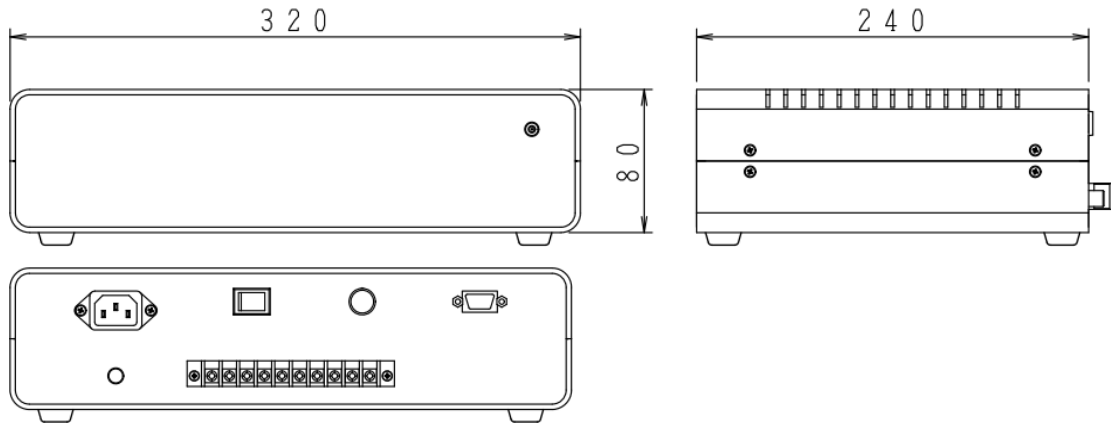

Figure 11-3. MS-711N Power Supply

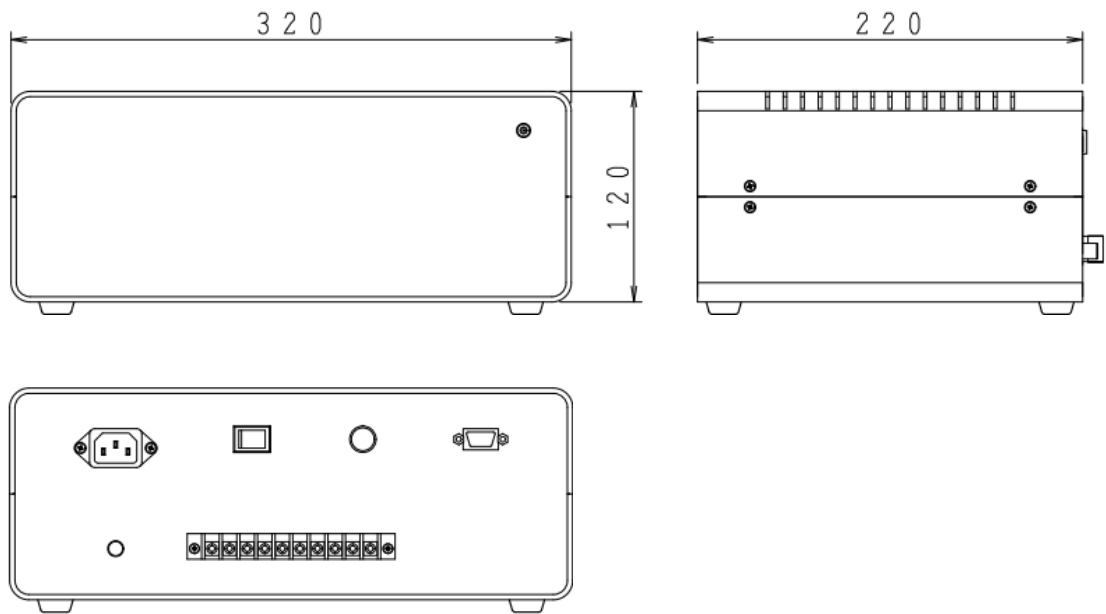

Figure 11-4. MS-712 Power Supply

11-6. Accessories List

Table 11-6. Accessories List

Option Items	Remarks
Sensor Cable	Cable Length: 20m, 30m
STR-22G	Double Arm Sun Tracker
STR-32G	Heavy Duty Sun Tracker
STR-32G DNI Measurement Mounting Plate	STR-32G Mounting Plate for MS-710/711 (Secondary Side)
Collimation Tube for MS-711	
Collimation Tube for MS-712	
Mounting Plate for Diffuse Measurement	
Shading Ball Assembly	Dual Type

11-7. Consumable Items

Table 11-7. Consumable Items

Parts Name	Remarks
Silica Gel	Particle size: $\phi 2.2 \sim \phi 11$
Fuse	$\phi 5.2 \times 20$, 250V, 2A



EKO Asia, Oceania

1-21-8 Hatagaya,
Shibuya-ku, Tokyo
151-0072 Japan
P. +81.3.3469.6713
F. +81.3.3469.6719
info@eko-instruments.com
www.eko-instruments.com

EKO North America

2570 North First Street,
Suite 200, San Jose,
CA 95131, USA
P. +1-408-977-7751
F. +1-408-977-7741
sales-usa@eko-instruments.com
www.eko-instruments.com

**EKO Europe,
Middle East, Africa,
South America**

Lulofsstraat 55, Unit 28,
2521 AL, Den Haag,
The Netherlands
P. +31 [0]70 3050117
sales-eu@eko-instruments.com
www.eko-instruments.com