

INSTRUCTION MANUAL

UV-A radiometer
UV-B radiometer

MS-10S
MS-11S

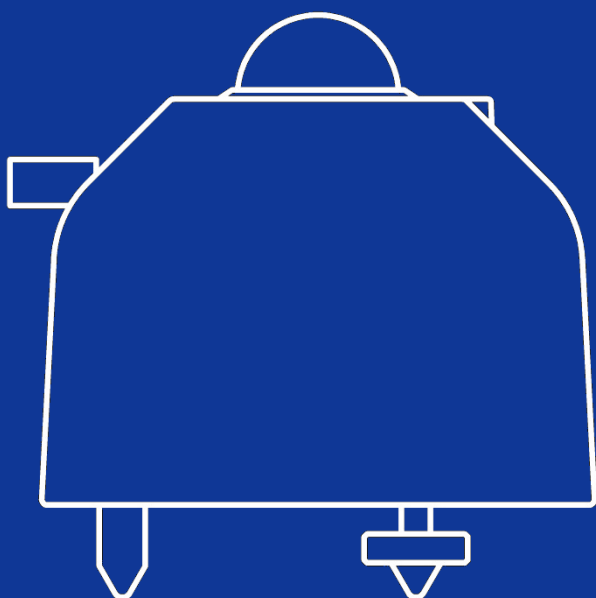

EKO

1. Index

1. Index	1
2. Important User Information	2
2-1. Contact Information	2
2-2. Warranty and Liability	2
2-3. About Instruction Manual	3
2-4. Environment	3
2-5. CE Declaration	4
3. Safety Information	6
3-1. General Warnings	6
4. Introduction	8
4-1. Main features	8
4-2. Package Contents	9
5. Getting Started	10
5-1. Parts Name and Descriptions	10
5-2. Setup	12
5-3. Wiring	14
5-4. Connections	15
5-5. Measurements	23
6. Maintenance & Troubleshooting	26
6-1. Maintenance	26
6-2. Troubleshooting	28
7. Specifications	30
7-1. Specifications	30
7-2. Dimensions	32
7-3. Output Cables	33
7-4. Accessories List	34
APPENDIX	35
A-1. Radiometric Terms	35
A-2. Software (Hibi)	36
A-3. Communication Specifications (Modbus RTU)	50
A-4. Communication specification (SDI-12)	59
A-5. About recalibration	61
A-6. Setting Report	62
A-7. Surge protection	63

2. Important User Information

Thank you for using EKO Products.

Reading this manual is recommended prior to installation and operation of the product. Keep this manual in a safe and handy place for whenever it is needed. For any questions, please contact us at below:

2-1. Contact Information

EKO INSTRUMENTS CO., LTD.

Asia, Oceania Region

www.eko-instruments.com
info@eko-instruments.com

EKO INSTRUMENTS Co., Ltd.
1-21-8, Hatagaya, Shibuya-ku
Tokyo, 151-0072 Japan

Tel: +81 [3] 3469-6713
Fax: +81 [3] 3469-6719

Europe, Middle East, Africa, South America Region

www.eko-instruments.com
sales-eu@eko-instruments.com

EKO INSTRUMENTS Europe B.V.
Lulofsstraat 55, Unit 28
2521 AL, The Hague, The Netherlands

Tel: +31 [0]70 3050117

North America Region

www.eko-instruments.com
sales-usa@eko-instruments.com

EKO INSTRUMENTS USA Inc.
2570 North First Street, Suite 200
San Jose, CA 95131 U.S.A.

Tel: +1 408-977-7751
Fax: +1 408-977-7741

2-2. Warranty and Liability

For warranty terms and conditions, please contact EKO Instruments or your distributor for further details.

EKO guarantees that all products have been tested to ensure the instrument meets its published specifications. The product warranty is valid only if the product has been installed and used according to the instructions provided in this operating manual.

In case any manufacturing defect[s] occurs, the defected part[s] will be repaired or replaced under warranty; however, the warranty will not be applicable if:

- Any modification or repair has been done by other than EKO service personnel.
- The damage or defect is caused by disrespecting the specifications published on the Product Sheet or Manual.
- The bubble level fails or stops working (this part will not be serviced or replaced by EKO under warranty)
- There is discoloration of the UV radiometer body, sun shield, and cable within a range that does not affect the function and performance of the product.

2-3. About Instruction Manual

Copy Rights Reserved by EKO INSTRUMENTS CO., LTD. Making copies of whole or parts of this document without permission from EKO is prohibited.

This manual was issued: Apr. 3, 2026

Version Number: 2

2-4. Environment

1. WEEE Directive [Waste Electrical and Electronic Equipment]



Although this product is not subject to the WEEE Directive 2002/96/EC, please make sure that it should not be disposed of in a landfill or with municipal or household waste. For proper processing, collection and recycling, please contact a specialist collection site or facility.

Disposing of this product correctly will help save valuable resources and prevent any potential negative effects on human health and the environment, which could otherwise arise from inappropriate waste handling.

2-5. CE Declaration



IMPOTANT USER INFORMATION



DECLARATION OF CONFORMITY

We: EKO INSTRUMENTS CO., LTD 1-21-8
Hatagaya Shibuya-ku, Tokyo 151-0072
JAPAN

Declare under our sole responsibility that the product:

Product Name: UV-A Radiometer, UV-B Radiometer
Model No.: MS-10S, MS-11S

To which this declaration relates is in conformity with the following
harmonized standards of other normative documents:

Harmonized standards:

EN 61326-1:2021 ClassA (Emission)
EN 61326-1:2021 (Immunity)

Following the provisions of the directive:

EMC-directive : 2014/30/EU

Date : July 15 , 2025

Position of Authorized Signatory : General Manager of R & D Center

Name of Authorized Signatory : Hitoshi Yokemura

Signature of Authorized Signatory : *Hitoshi Yokemura*



DECLARATION OF CONFORMITY

We: EKO INSTRUMENTS CO., LTD 1-21-8
Hatagaya Shibuya-ku, Tokyo 151-0072
JAPAN

Declare under our sole responsibility that the product:

Product Name : UV-A Radiometer, UV-B Radiometer

Model No. : MS-10S, MS-11S

To which this declaration relates is in conformity with the following harmonized standards of other normative documents:

Harmonized standards:

EN IEC 63000 : 2018. [RoHS]

Date : July / 17 / 2025

W/m
Position of Authorized Signatory : Director of Quality Assurance

Name of Authorized Signatory : Taiji Yamashita

Signature of Authorized Signatory : 

3. Safety Information

EKO Products are designed and manufactured with consideration for safety; however, please make sure to read and understand this instruction manual thoroughly to be able to operate the instrument safely in the correct manner.



WARNING CAUTION

Attention to user; pay attention to the instructions given on the instruction manual with this sign.



HIGH VOLTAGE WARNING

High voltage is used; pay special attention to instructions given on this instruction manual with this sign to prevent electric leakage and/or electric shocks.



3-1. General Warnings

1. Setup

- The installation base or mast should have enough load capacity for the instrument to be mounted. Fix the UV radiometer securely to the base or mast with bolts and nuts; otherwise, the instrument may drop due to a gale or an earthquake, which may lead to unexpected accidents.
- Make sure to install the instrument and cables in a suitable location, and avoid submersion in water.
- Insert the output cable into the connector port on the back of the sensor unit and tighten it all the way. Push the connector in, and check to make sure the screw is tight. If the connection is loose, water can enter the unit and cause it to malfunction.
- When connecting this product to a measuring instrument, the shield wire of the output cable shall be connected to ground earth for the UV radiometer. Otherwise noise may occur in the measurement data. In addition, the surge protection circuit inside the UV radiometer will not operate properly if the shield wire is not connected to ground earth.
- Although this product is tested to meet EMC Directive compliance requirements, it may not fully satisfy its primary specification/performance when using this product near following locations where strong electromagnetic wave is generated. Please pay attention to the installation environment.
Outdoor: High voltage power line, power receiver/distribution facility, etc.
Indoor: Large-size chiller, large electric motors, microwave, etc.
- Do not use this product in the environment where corrosive gas, such as ammonia and sulfurous acid gas, are generated. It may cause malfunction.
- Do not install in the area that cause salt damages. It may cause malfunction by paint peeling off or corrosion. When installing in the area with risk of salt damages, make sure to take following measures:
 1. Wrap the connector with self-fusing tape
 2. Change the fixing screw to bolt screw made of aluminum
 3. Run the cables in a plastic or metal pipe treated with salt-resistant paint such as molten zinc plating
 4. Periodically clean.
- Do not use this instrument in the vacuum environment.
- For proper grounding use the original cable provided.

- If the cable and sensor is in risk for getting damaged by birds and small animals, protect the cable and the sensor by using:
 1. Reflective tape
 2. Repellent
 3. Cable duct
 4. Installing bird-spike
- When using the configurable 0 to 1V output from UV radiometer, please use a precision resistor 100Ω.
- The settings can be changed with the RS485 / USB conversion cable and dedicated software.

2. Handling

- Be careful when handling instruments with glass domes. Strong impact to this part may damage the glass and may cause injuries by broken glass parts.
- When carrying any model with the sun screen attached, always hold the instrument from the bottom. Holding only the sun screen part may lead to dropping the sensor as it comes off from the sun screen.

3. Signal Cable

- Make sure to ground the signal cable. When grounding is insufficient, it may cause not only measurement error due to noise, but also cause electric shock and leakage accidents.
- Check the voltage and types of specified power supply before connecting this instrument. When improper power supply is connected, it may cause malfunction and/or accident.
- Use this instrument with 0.5A fuse connected to the power supply line in series. Without connecting the fuse, it has risks of generating heat and fire due to large-current flowing by the power supply when internal damage of the electronics occurs.

4. About RS485 Modbus RTU connection

- This product supports communication through the RS485 Modbus RTU.
- It is recommended to use the optional EKO converter cable when connecting MS-10S/11S to a PC.
- Depending on the USB-RS485 converter type, an additional termination resistor (120Ω) and/or pull-up/pull-down resistor (680Ω) is required for proper communication.
- When connecting to a RS485 (Modbus RTU) master peripheral device, an additional termination resistor (120Ω) and/or pull-up/pull-down resistor (680Ω) is required for proper communication.

4. Introduction

The MS-10S is an UV radiometer that continuously measures irradiance in the UV-A region (315-400nm), and the MS-11S is in the UV-B region (280-315nm).

The ozone layer absorbs harmful ultraviolet radiation from the sun and plays an important role in protecting human beings and other living things. Recently, it has been confirmed that the ozone layer is decreasing, and this has become a major problem.

UV irradiance is usually divided into three wavelength ranges: UV-A (315-400nm), UV-B (280-315nm), and UV-C (below 280nm). Of these, UV-A light is only slightly absorbed by the ozone layer, so it is not affected by changes in the ozone layer. UV-B light fluctuates greatly depending on the amount of ozone and is harmful to living things, so it is generally referred to as "harmful ultraviolet light."

4-1. Main features

1. Capable of measuring ultraviolet radiation in the UV-A and UV-B spectral region
2. Rainproof structure for constant measurement
3. Multioutput (Modbus RTU, 4-20mA, 0-10mA/0-1V with external 100Ω precision shunt resistor.)
For MS-10S/11S with the serial numbers listed below allow switching between Modbus RTU and SDI-12 digital output signals.
MS-10S: UVA22001~UVA22023, EX22234.01~EX22392.02
MS-11S: UVB22001~UVB22017, EX22166.17~EX22392.05
4. Wide voltage supply input range (5VDC or 8-30VDC)
5. With built-in tilt/roll sensor

4-2. Package Contents

Check the package contents first; if any missing parts or any damage is noticed, please contact EKO immediately.

Table 4-1. Package Contents

Contents	MS-10S/11S
UV radiometer	○
Output Cable	○ ^[1]
Sun screen	○
Instruction Manual	Not included in the package. (Please download the manual from the EKO website.)
Setting Report	○ ^[2]
Calibration certificate	○
Temperature dependency report	○
Cosine response report	○
Quick Start Guide	○
Fixing Bolts	[M5] x2 [Bolt Length: 75mm]
Washers	[M5] x4
Nuts	[M5] x2

[1] In case of MS-10S/11S, standard length is 10m for signal/power cable. For different length of cable [e.g. to meet your application needs] please contact EKO or your local distributor.

[2] Details about the setting report, see appendix A-6.

5. Getting Started

5-1. Parts Name and Descriptions

Each part name and its main function is described below.

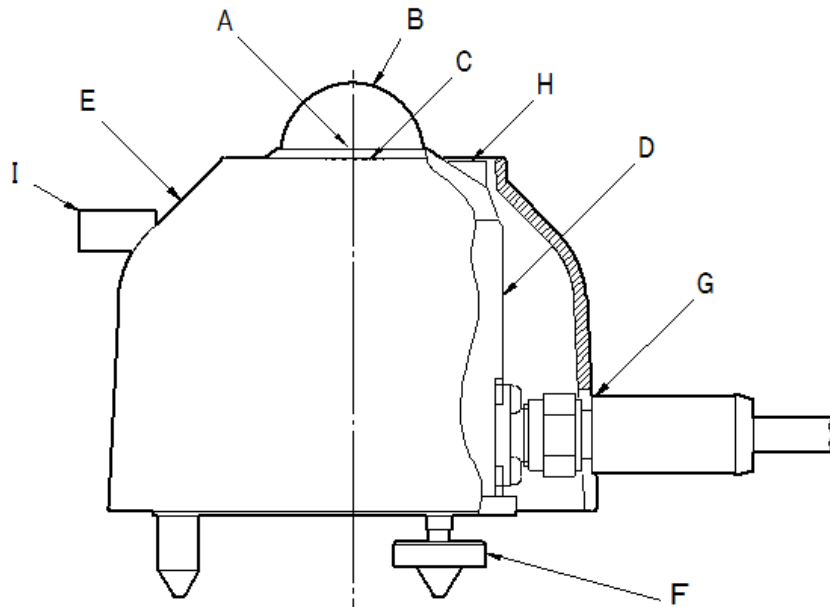

Table 5-1. Parts Name

Parts Name
A. Diffuser
B. Glass Dome
C. Detector
D. Body
E. Sun screen
F. Levelling Screw
G. Cable, Connector
H. Spirit Level
I. Knurling Screw

*Signal converter is built-in for MS-10S/11S.

Figure 5-1. UV radiometer Parts Name

1. Glass Dome, Quartz Diffuser

A glass dome creates a sealed environment for the detector and protects it against dirt and rain. The dome of the EKO UV radiometers is only transparent for radiation emitted by the sun. The combination of the glass dome and the Quartz diffuser give a 180 degrees field of view and good cosine response.

2. Detector

The heart of the product is the detector (UV-A or UV-B dedicated photodiode), which generates a voltage proportional to the irradiance of UV-A or UV-B spectral region. The detector determines the main characteristics of the UV radiometer (response time, temperature characteristics, non-linearity, sensitivity constant, etc.).

3. Sun screen, Body

MS-10S/11S have a sun screen to prevent any excessive body temperature increase generated by direct sun light. Weather resistant metals are used to reduce the effects and degradation caused by heat radiation, rain, and windblown dusts.

4. Spirit level

The integrated spirit level is used for setup and maintaining the sensor in a horizontally levelled position.

* Please note: Depending on the operating environment, the bubble may eventually disappear from the level gauge as the liquid dissipates. The reference circle may also fade out, or cracks may occur.

5. Drying agent

Enclosed drying agents inside the sensor body keep the sensor inside dry, prevents condensation of humidity inside of the glass dome.

6. Cable and Cable Connector

MS-10S/11S are shipped with a 10 meter long output cable as standard length*.

Durable materials are used for the cable and connector, and pin terminals are attached at the end of the cable for easy connection with a data logger terminal block.

* If longer cables, round terminals or fork terminals are required, please contact EKO Instruments or your distributor. Also see [7. Specification, 7-4. Accessories List] for optional items.

The connector should be protected by the self-fusing tape when the UV radiometers are used in the areas with the risk of the salt damage.

5-2. Setup

In order to obtain high quality measurements from UV radiometers, several criteria with respect to setup and mounting of the instruments have to be considered. Also see the Quick Start Guide for comprehensive setup instruction details

The ideal mounting position for a UV radiometer is a location which has a full hemispheric field-of-view without any obstructions [such as buildings, trees, and mountains]; however, it might be difficult to find such locations. Therefore, in practice, it is ideal to install in a position which is free from obstructions at 5° above horizon.

The setup location should be easily accessible for periodic maintenance [glass dome cleaning], and avoid surrounding towers, poles, walls or billboards with bright colors that can reflect solar radiation onto the UV radiometer.

A strong physical impact to the UV radiometer can lead to product damage and/or may cause changes to the sensitivity.

1. Installing at Horizontal or Tilted Position

- 1) Check the installation base where the UV radiometer has to be mounted and make sure it has two fixing holes with the appropriate pitch. The pitch sizes of the fixing holes are as follows [in mm]:

Table 5-2. Fixing Hole Pitch and Bolt Size for UV radiometers

	MS-10S/11S
Fixing Hole Pitch	65 mm
Fixing Bolt Size	M5 x 75 mm

- 2) Remove a sun screen
The sun screen can be removed by loosening the knurling screw and sliding it towards the spirit level direction.
*When carrying MS-10S/11S with a sun screen attached, always hold the instrument from the bottom. Holding only the sun screen may lead to dropping the sensor as it comes off from the sun screen.
- 3) There are two ways to setup the UV radiometer (Horizontal or inclined).

Installing at horizontal Position

Setup the UV radiometer with the signal cable connector facing the nearest Earth's pole. In the Northern hemisphere, the connector should be orientated North, in the Southern hemisphere, the connector should be orientated South. Adjust the UV radiometer in a horizontal position by using the 2 levelling screws observing the air bubble in the spirit level while manipulating the levelling screws. The instrument is levelled horizontally if the air bubble is in the centre ring. The sensitivity of the bubble vial is (0.1° / mm). If the UV radiometer is not levelled properly, the UV radiometer readings are affected by cosine and azimuth errors. Periodically check the spirit level and adjust the UV radiometer's position if necessary.

Installing at an inclined angle

After the MS-10S/11S is adjusted to horizontal position in levelled surface, install it on tilted a tilted mount.

In the case of MS-10S/11S, it is possible to acquire tilt information obtained from the built-in tilt position sensor through Modbus RTU. The sensor position can be measured in two different planes (X,Y).

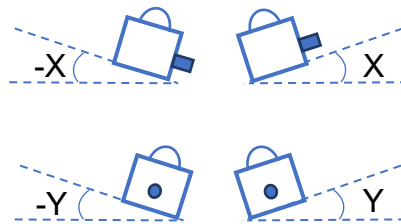

<Tilt (X axis)> (180° to 0) and (0 to -180°)
 <Roll (Y axis)> (180° to 0) and (0 to -180°)

Figure 5.2A Tilt angle (-180 to 0°) and (0 to 180°)
 Roll angle (-180 to 0°) and (0 to 180°)

The tilt and roll angles are relative to the calibrated X and Y axis of the sensor and surface mounting plane X' and Y'. When the sensor is positioned in the same plane X = X' and Y = Y', the measured tilt and roll angles (X and Y) correspond to plane of installation X' and Y'.

The UV radiometer connector is an important reference for setup and corresponds to the X-axis reference plane.



For setup at horizontal plane: Setup the UV radiometer with the signal cable connector facing the nearest Earth's pole. In the Northern hemisphere, the connector should be orientated North, in the Southern hemisphere, the connector should be orientated South. If the cable is not oriented to the nearest pole, it does not affect the angle measurement. The angle measurement reflects the tilt and roll of the corresponding sensor position.

For setup at inclined plane: Setup the UV radiometer with signal cable aligned with the installation platform (X', Y'), see figure 5-2B. When the sensor is not aligned, the tilt (X) and roll (Y) measurement does not reflect the angle X' and Y', see figure 5-2C.

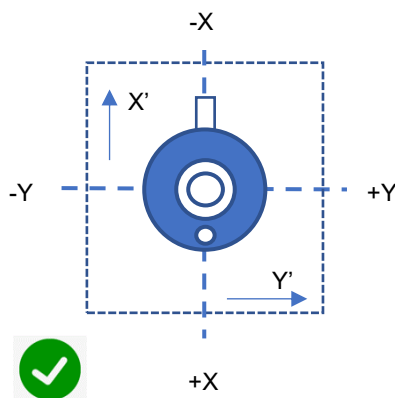

Figure 5-2B Tilt and roll angle corresponding to reference plane

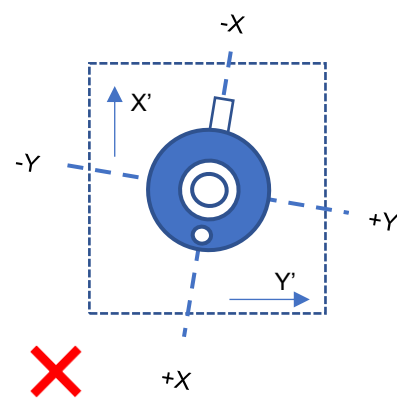

Figure 5-2C Tilt and roll angle not corresponding to reference plane

- 4) Fasten the UV radiometer to the base with the 2 bolts [included] and put the sun screen back on the UV radiometer.

5-3. Wiring

To extend the cable lifetime, make sure that the cables are not exposed to direct sun light or rain/wind by lining the cable through a cable conduit. Cable vibrations will potentially cause noise in the output signal. Fasten the cable so that the cable does not swing or move by wind blowing. Exposure of the signal cable to excessive electromagnetic emissions can cause noise in the output signal as well. Therefore, the cable should be lined at a safe distance from a potential source generating EMC noise, such as an AC power supply, high voltage lines or telecom antenna.

1. Ground connection



The UV radiometer housing is connected to the shield wire of the cable, so connect the shield wire to the ground on the measuring instrument side.

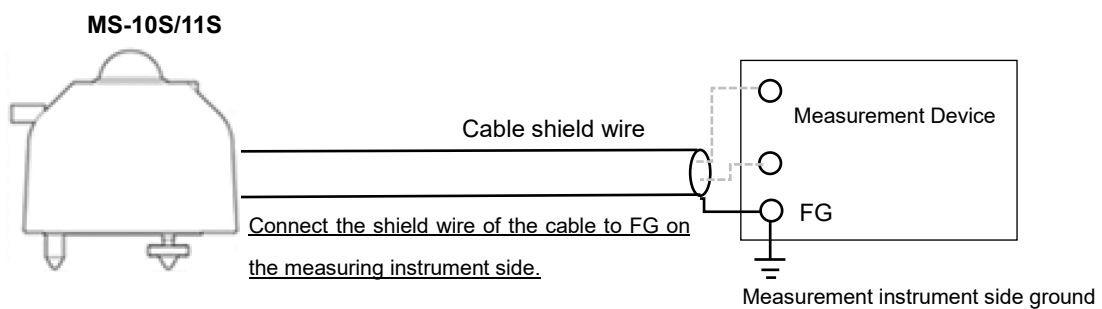

Figure 5-3. MS-10S/11S ground connection method

2. Wiring procedure

Connect the output cable to the MS-10S/11S: **Insert the output cable into the connector port on the back of the sensor unit, and twist clockwise to fasten it. Make sure to tighten the connector all the way.**



- 1) **If the connection is loose, water can enter the unit and cause it to malfunction.**
- 2) Secure the length of the cable to avoid it from being pulled loose.
- 3) Connect the power cable grounding wire to prevent electrical shocks.

5-4. Connections

The MS-10S/11S is based on a digital Smart processing interface providing advanced measurement functions with 3 different industrial signal outputs (**Modbus RTU**, configurable **4-20mA** and **0-1V** with external shunt resistor 100Ω). For MS-10S/11S with the serial numbers listed below allow switching between **Modbus RTU** and **SDI-12** digital output signals.

MS-10S: UVA22001~UVA22023, EX22234.01~EX22392.02

MS-11S: UVB22001~UVB22017, EX22166.17~EX22392.05

Table 5-3. UV radiometer outputs

Output	MS-10S/11S
Modbus RTU (Default)	○
4 - 20 mA (Default)	○
0 -1V ^[1]	○
SDI-12 ^[2]	[2]

[1] 0-10mA output with external precision shunt resistor 100Ω

[2] SDI-12 output is only supported by MS-10S/11S with the following product serial numbers.

MS-10S: UVA22001~UVA22023, EX22234.01~EX22392.02

MS-11S: UVB22001~UVB22017, EX22166.17~EX22392.05

Table 5-4. UV radiometer output parameters

Output parameters	Modbus	4-20mA	0-1V	SDI-12 ^[1]
Irradiance	○	○	○	○
Temperature	○			○
Tilt position	○			○
Alerts for abnormal internal humidity of the UV radiometer	○			○
Relative humidity	○			○
Sensor information	○			○

[1] For MS-10S/11S with the serial numbers listed below allow switching between

Modbus RTU and SDI-12 digital output signals.

MS-10S: UVA22001~UVA22023, EX22234.01~EX22392.02

MS-11S: UVB22001~UVB22017, EX22166.17~EX22392.05

Voltage output (0-1V)

The current output can be converted into a voltage output when a shunt resistor is used in series. The default output is 4-20mA. The 0-10mA (0-1V) output is disabled. The settings can be changed when the MS-10S/11S is connected to a PC through the Hibi software, see appendix 3 for instruction.

Connect the 3 wires with corresponding color to the input terminals of the Voltmeter or data logger (figure 5-5). Connect the power terminals to a DC power supply [8 to 30 V]. We recommend to use a fuse [0.5A] to the DC power supply line [+] for over current protection. The precision shunt resistor (0.1%, T.C.R. 15 ppm) need to be placed across the voltage input terminals of the measurement device.



Interconnect the power supply (-) and 0-1V (-) line. The MS-10S/11S voltage output requires a 3 wire connection.

- **To protect your equipment from noise and surges, the shield wire of the cable must be connected to ground at a single point. If it is not connected, the electronic equipment may be damaged.**
- **The shield wire of the cable is connected to the surge protection circuit inside the UV radiometer itself and to the enclosure.**
- **Be sure to connect a fuse, as this may lead to a fire.**

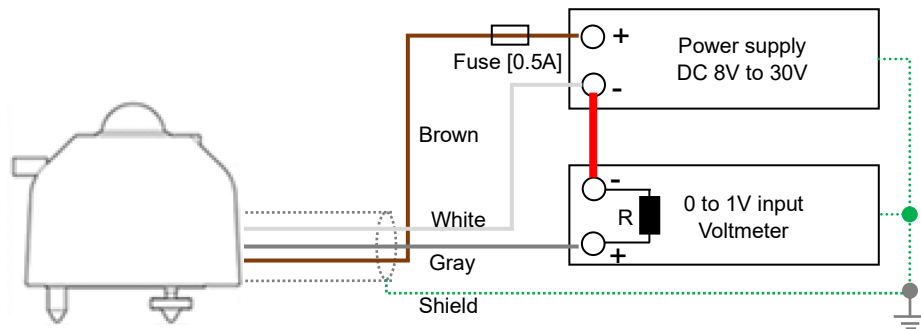

Figure 5-5. How to connect MS-10S/11S (0-1V output)



When using a shunt resistor to convert current to voltage, use a precision resistor which can make the converted voltage less than two third of the power supply voltage.

To convert 0-10mA to 0-1V output, use a 100 Ω precision resistor (0.1%, 15ppm).

To convert 4-20mA to 1-5V output, use a 250 Ω precision resistor (0.1%, 15ppm).

2. Digital output (Modbus RTU / SDI-12)

The MS-10S/11S can work in two digital output modes, respectively Modbus RTU.

For MS-10S/11S with the serial numbers listed below allow switching between Modbus RTU and SDI-12 digital output signals. Modbus RTU and SDI-12. Modbus RTU output is set to default, the SDI-12 output can be selected through the Hibi software.

MS-10S: UVA22001~UVA22023, EX22234.01~EX22392.02

MS-11S: UVB22001~UVB22017, EX22166.17~EX22392.05

PC connection (Modbus RTU)



EKO can provide an optional and approved USB converter for connection with a PC. The converter cable is needed for setup, sensor diagnostics and data logging through the Hibi software. Depending on your region, the optional converter can be different.

- **To protect your equipment from noise and surges, the shield wire of the cable must be connected to ground at a single point. If it is not connected, the electronic equipment may be damaged.**
- **The shield wire of the cable is connected to the surge protection circuit inside the UV radiometer itself and to the enclosure.**
- **Be sure to connect a fuse, as this may lead to a fire.**

For any converter with screw terminals or open wires, connect the 4 wires of the sensor cable with the corresponding wire color to the RS485 to USB converter (figure 5-6). Some converter cables provide a 5V supply voltage from the USB port, in such case no additional power supply is required. In any other case use an additional power supply. Connect the power terminals to a DC power supply [8 to 30 V]. We recommend to use a fuse [0.5A] to the DC power supply line [+].

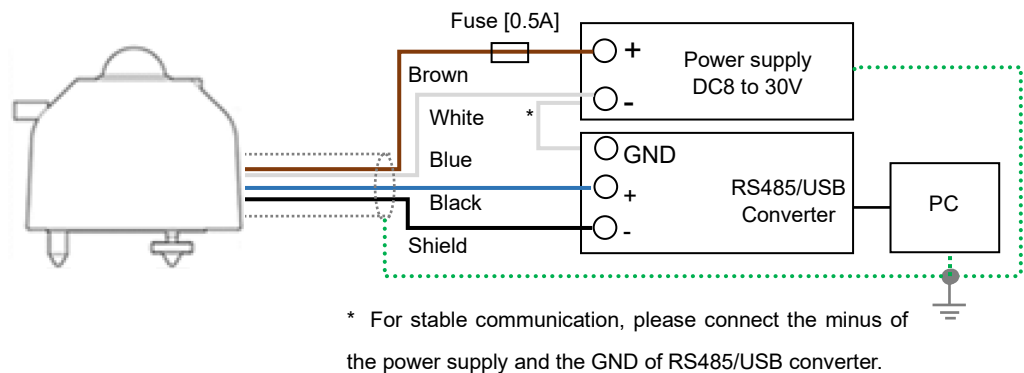

Figure 5-6. How to connect MS-10S/11S (Modbus RTU)



Depending on the converter type and design properties, some commercial RS485 to USB converters may not work properly. A termination resistor is required to prevent reflections from the end of the transmission line. Pull-up and pull-down resistors are necessary to keep the voltage level constant when the transmission line is in a high impedance state.

Data logger connection (Modbus)

Connect the 4 wires of the sensor cable with the corresponding wire color to the RS485 communication port of the data logger master and power supply unit (figure 5-7). Connect the power terminals to a DC power supply [8 to 30 V]. We recommend to use a fuse [0.5A] to the DC power supply line [+] for over current protection.

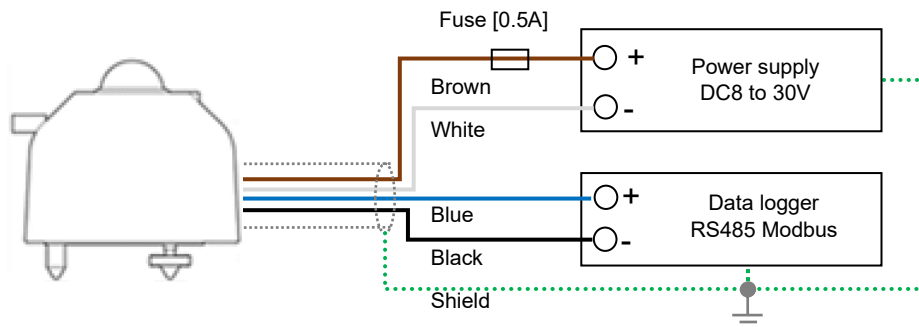

Figure 5-7. How to connect MS-10S/11S (Modbus RTU RS485)

MS-10S/11S can be configured within a multi sensor RS485 Modbus RTU communication network. Up to 31 sensors per one Master can be connected and be assigned with a unique address. For a multiple sensor network the sensors need to be configured according to the recommended RS485 configuration standards as shown in figure 5-8.

The master represents the data-logging device and slaves represent devices such as MS-10S/11S or other serial devices in the same network. Connect the communication wires of the slave to the Modbus RTU communication input of the master. Connect a 120Ω termination resistor at the end of the communication line. The master device may have an integrated termination resistor and pull-up and pull-down resistors. If any communication issues occur, apply those separately.

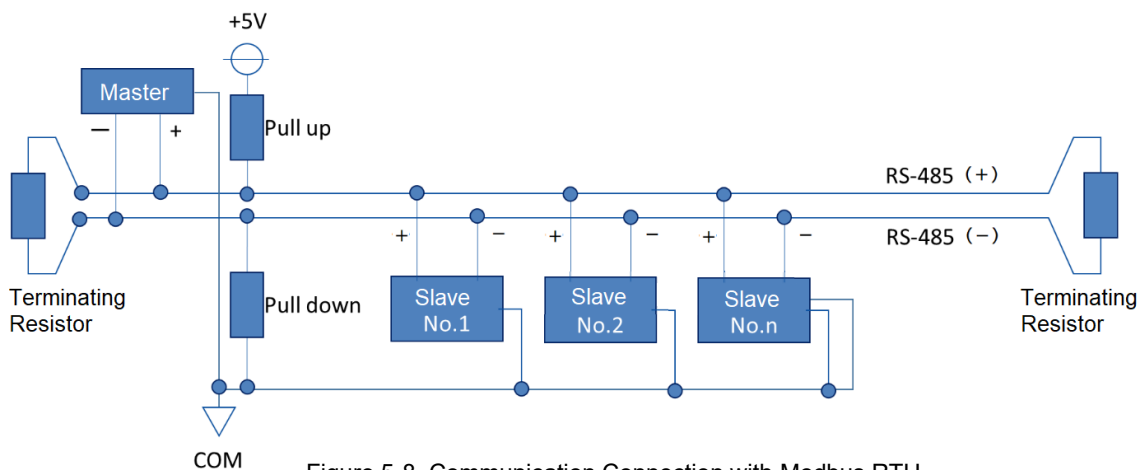

Figure 5-8. Communication Connection with Modbus RTU



Apply a Termination resistor (typically 120 to 150Ω) : Typically reflections occur on long lines, resulting in a receiver misreading logic levels. Proper termination prevents reflections, improving data integrity.

Apply Pull-up and pull-down resistors (typically 680 to 850Ω): Necessary to keep the voltage level constant when the transmission line is in a high impedance state.



Communication errors may occur depending on the connection distance and the number of connections. In that case, please prepare and apply a RS485 booster or a repeater.

Communication problems may occur if Modbus RTU and SDI-12 are used at the same time.



- Although a surge protection board is embedded inside the UV radiometer, if the cable length exceeds 10 m, add an appropriate SPD or the like to protect the measurement system from lightning surges (see A-7).

Data logger connection (SDI-12)

For MS-10S/11S with the serial numbers listed below allow switching between Modbus RTU and SDI-12 digital output signals. Modbus RTU and SDI-12. Modbus RTU output is set to default, the SDI-12 output can be selected through the Hibi software.

MS-10S: UVA22001~UVA22023、EX22234.01~EX22392.02

MS-11S: UVB22001~UVB22017、EX22166.17~EX22392.05

Connect the 3 wires of the sensor cable with the corresponding wire color to the SDI-12 communication port of the data logger master and power supply unit (figure 5-9). Connect the power terminals to a DC power supply [12 V]. We recommend to use a fuse [0.5A] to the DC power supply line [+] for over current protection.



Interconnect the power supply (-) and SDI-12 (-) line.

- **Communication problems may occur if Modbus and SDI-12 are used at the same time.**



- **Although a surge protection board is embedded inside the UV radiometer, if the cable length exceeds 10 m, add an appropriate SPD or the like to protect the measurement system from lightning surges (see A-7).**

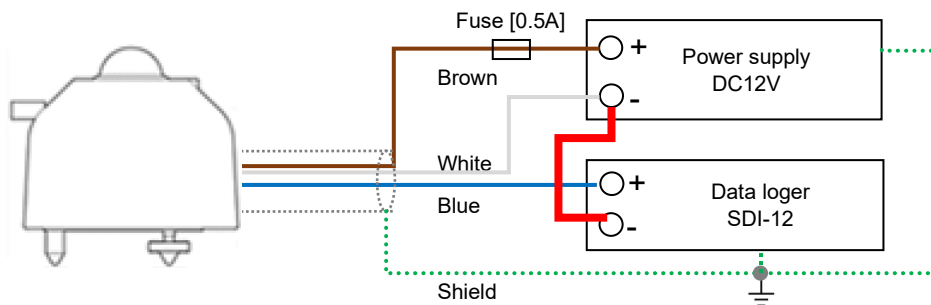

Figure 5-9. How to connect MS-10S/11S (SDI-12)

MS-10S/11S can be configured within a multi sensor SDI-12 communication network. Up to 20 units of S-series sensors can be connected and be assigned with a unique address(*). For a multiple sensor network the sensors need to be configured according to the recommended SDI-12 configuration standards as shown in figure 5-10. Make sure the cable length between the connecting slave and master be less than 60m.

The shield cable must be connected to the ground, otherwise noises may occur.

(*) When connecting other SDI-12 communication devices, the upper limit may change.

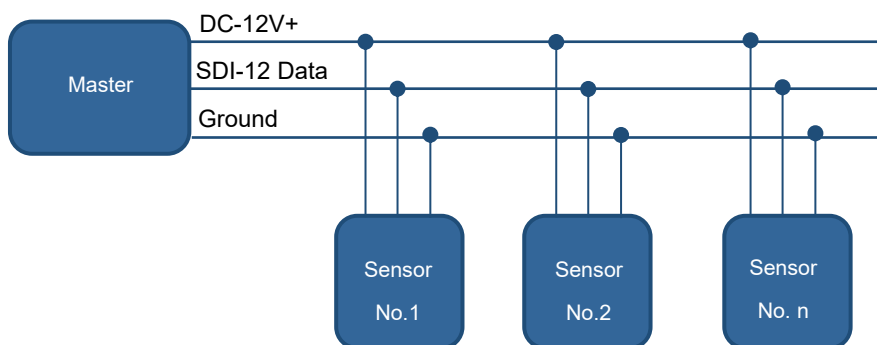

Figure 5-10. Communication Connection with SDI-12

3. Overview wire assignments

Table 5-5. Color Codes of cable

No.	Wire Color	4-20mA	Modbus	0-1V ^[1]	SDI-12 ^[2]
1.	Brown (+)	8 to 30VDC (+)	5VDC (+) or 8 to 30VDC (+)	8 to 30VDC (+)	12VDC (+)
2.	White (-)	4~20mA (-) / GND	Vcc GND / RS485 GND	0~10mA (-) / 0-1V (-) / GND	Vcc GND
3.	Blue (+)	---	RS485 (+)	---	SDI-12 Data (+)
4.	Black (+)	---	RS485 (-)	---	---
5.	Gray (+)	4~20mA (+)	---	0~10mA (+) / 0-1V (+)	---
Shield	Shield	FG	FG	FG	FG

[1] When selecting 0-1V output, a precision resistor is required separately.

[2] SDI-12 output is only supported by MS-10S/11S with the following product serial numbers.

MS-10S: UVA22001~UVA22023, EX22234.01~EX22392.02

MS-11S: UVB22001~UVB22017, EX22166.17~EX22392.05

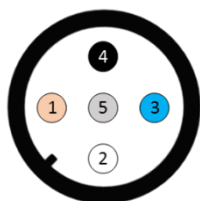

Each number corresponds to the number in Table 5-5.

Figure 5-11. Connector pin number

5-5. Measurements

1. Data logger settings

The output voltage is measured by a measuring device such as a voltmeter or a data logger. If solar irradiance is measured continuously, it is recommended to use a data logger, which has sufficient memory to record data over a longer period and functions to process the measurement parameters of the UV radiometer. Depending on the sensor output which will be used, the data logger should be capable to measure the assigned output type.

For the MS-10S/11S with current output, Modbus RTU and SDI-12 ^[1], the data logger should have one of those inputs. For MS-10S/11S the input range, resolution and impedance are not critical, and considered as standard for any meteorological or industrial type data logger. For current measurement the measurement range should be selected according to the range settings of the MS-10S/11S.

When configuring the data logger parameters, the sampling rate and data reduction methods can be defined right at the beginning of the data acquisition process. The response time that is given in the specifications of the EKO UV radiometers states the amount of time, which is necessary to reach 95% of the final measurement value. It is also possible to define a 63.2% response [which is equal to $1-1/e$]. This time constant, represented by the symbol τ , is 3 times smaller than the values specified by EKO. The recommended ^[1] sampling rate for UV radiometer is smaller than τ . So, for EKO UV radiometers, the sampling rates that have to be programmed in the data logger systems should not exceed the values as given in Table 7-1.

Performing averaging and/or integration of measurement data can be meaningful to, e.g., reduce the data volume or to meet application-specific requirement. Note that shorter sampling rates allow to use shorter averaging/integration times. It could also be meaningful to store not only average values, but to keep track of all statistical values during the averaging period, namely: average, integral, minimum and maximum values, and standard deviation. As a general recommendation, the averaging/integration period should be as short as possible, but long enough to reduce the data volume to store the processed data safely.

[1] SDI-12 output is only supported by MS-10S/11S with the following product serial numbers.

MS-10S: UVA22001~UVA22023, EX22234.01~EX22392.02

MS-11S: UVB22001~UVB22017, EX22166.17~EX22392.05

2. UV radiometer default settings

The MS-10S/11S is based on a digital Smart processing interface providing advanced measurement functions with 3 different industrial signal outputs (**Modbus RTU**, **4-20mA**, configurable **0-10mA** and **0-1V** with external precision shunt resistor 100Ω).

For MS-10S/11S with the serial numbers listed below allow switching between **Modbus RTU** and **SDI-12** digital output signals.

MS-10S: UVA22001~UVA22023, EX22234.01~EX22392.02

MS-11S: UVB22001~UVB22017, EX22166.17~EX22392.05

Where to find information regarding the MS-10S/11S defaults settings and important parameters:

Table 5-6. MS-10S/11S where to find the settings

Items	Default setting parameters
Sensitivity figure	<ul style="list-style-type: none"> - Calibration certificate - Modbus register - SDI-12^[1] register
Modbus RTU (Default)	<ul style="list-style-type: none"> - Setting report (see appendix A-6 Setting report) - Modbus register <ul style="list-style-type: none"> o Address (last two digits of serial number, 100 if “00”) o Baud rate 19200 o Parity Even
SDI-12 ^[1]	<ul style="list-style-type: none"> - Setting report - SDI-12 register <ul style="list-style-type: none"> o Address 0 o Baud rate 1200 - Parity Even
4 - 20 mA (Default)	<ul style="list-style-type: none"> - Setting report <ul style="list-style-type: none"> o 4-20mA = 0-150W/m² or 0-10,000mW/m²
0 - 10 mA	<ul style="list-style-type: none"> - Setting report <ul style="list-style-type: none"> o 0-10mA = 0-150W/m² or 0-10,000mW/m²
0 – 1V	<ul style="list-style-type: none"> - Setting report <ul style="list-style-type: none"> o 0-1V = 0-150W/m² or 0-10,000mW/m²

[1] SDI-12 output is only supported by MS-10S/11S with the following product serial numbers.

MS-10S: UVA22001~UVA22023, EX22234.01~EX22392.02

MS-11S: UVB22001~UVB22017, EX22166.17~EX22392.05

3. UV Irradiance conversion

4-20mA output

If the measurement range can be selected on the data logger, select the measurement range, which can accurately measure the signal within a range of 4 to 20[mA]. The output for the MS-10S is set to be 150[W/m²] at 20[mA] and MS-11S is set to be 10,000[mW/m²] at 20[mA].

When the UV irradiance current value is **A**, the UV irradiance **I** can be determined by the following formula:

$$\text{MS-10S} \quad I [\text{W/m}^2] = (\mathbf{A} [\text{mA}] - 4) \times (150 / 16)$$

$$\text{MS-11S} \quad I [\text{mW/m}^2] = (\mathbf{A} [\text{mA}] - 4) \times (10,000 / 16)$$

0-1V output

If the measurement range can be selected on the data logger, select the measurement range, which can accurately measure the signal within a range of 0 to 1[V]. The output for the MS-10S is set to be 150[W/m²] at 1[V] and MS-11S is set to be 10,000[mW/m²] at 1[V].

When the UV irradiance voltage value is **V**, the UV irradiance **I** can be determined by the following formula:

$$\text{MS-10S} \quad I [\text{W/m}^2] = \mathbf{V} [\text{V}] \times 150$$

$$\text{MS-11S} \quad I [\text{mW/m}^2] = \mathbf{V} [\text{V}] \times 10,000$$

MS-10S/11S [Modbus RTU Output, SDI-12^[1] Output]

When using the digital output (Modbus or SDI-12^(*)) by default the irradiance conversion is performed on-board and is one of the measurement parameters within the data string.

[1] SDI-12 output is only supported by MS-10S/11S with the following product serial numbers.

MS-10S: UVA22001~UVA22023, EX22234.01~EX22392.02

MS-11S: UVB22001~UVB22017, EX22166.17~EX22392.05

4. Daily UV radiant energy

The total daily radiant energy in Joule per meter squared [J/m²] is obtained by integrating the UV irradiance over time. To calculate the total daily UV radiant energy in Joule per meter square [J/m²], multiply the averaged UV irradiance **I** by the averaging interval period [s]. Then sum-up the total data number [n] of averaged data points in one day.

Its physical unit is expressed with [J/m²] and can be calculated with [J] = [W·s]

$$DTI = \sum_{k=1}^n I_k \times t^k$$

6. Maintenance & Troubleshooting

6-1. Maintenance

By using the UV radiometers accurate results can be obtained if the glass dome and the condition of the instrument are maintained properly. Furthermore, regular maintenance and scheduled re-calibrations can extend the lifetime of the UV radiometers. However, environmental conditions, such as for instruments mounted near highly frequented traffic lanes or airports, may have a deteriorating effect on the materials. Therefore, proper maintenance is needed and has to be adapted to the local environmental conditions.

The following table describes the common maintenance tasks that should be performed on a regular basis:

Table 6-1. Maintenance Items1

Maintenance Item	Frequency	How To	Effect
Clean Glass Dome	Several times per week	Keep the glass dome clean by using demineralized water and wiping with a soft cloth dry and clean.	The irradiance measurement will be affected due to a change in transmittance.
Check Appearance Condition	Weekly	Check for cracks and scratches on the glass dome and body.	May lead to shade on the detector and enhanced soiling.
Check Spirit level	Weekly	Verify if the UV radiometer is levelled by checking the bubble is in the center ring of spirit level. [When the UV radiometer is setup in horizontal position].	An additional cosine/azimuth error will be introduced.
Check Cable Condition	Weekly	Verify if the cable connector is properly connected, tightened to the instrument, and how cable is lined; make sure the cable is not shaking from the wind.	A disconnected cable will cause sporadic reading errors or failure of operation. If the cable is damaged, it may lead to noise or electric shock.
Check Setup Base Condition	Weekly	Check if the instrument is tightened properly to the mounting base plate and the base plate and/or table is securely fastened in a proper condition.	Loose instruments and/or mounting plates can lead to damages of the instruments and/or injury.
Check the Sun screen	Weekly, Before/ After Bad Weather	Verify if the sun screen is securely fixed on the body, and knurling screw is securely tightened.	May lead to damaging the instrument and/or lead to increasing measurement error due to temperature increase by sun screen coming off.
Recalibration	Every 2 Years	To maintain the best possible measurement accuracy, recalibration of the UV radiometer is recommended. Contact EKO for more details and requests for a recalibration and maintenance service.	Due to natural aging of materials the detector sensitivity of the UV radiometer can gradually change over time.

Table 6-2. Maintenance Items2 (Advanced remote check can be done)

Maintenance Item	Frequency	How To	Effect
Data validity	Weekly	Check the daytime irradiance data and compare to previous days or adjacent UV radiometers.	When large difference occurs operating problems or installation issues can be detected.
Presence of noise	Weekly	Check night-time irradiance values	Night-time offsets and sensor stability issues can be revealed.
Abnormal temperature detection	Weekly	Check the body temperature via Modbus RTU output.	If the inside temperature becomes abnormally high, the life of the product will be shortened.
Confirm the effect of desiccant	Weekly	Check the relative humidity via Modbus RTU output.	The condition of the drying agent can slightly change over time. If the relative humidity become high, the glass dome might be fogging up.
Checking the tilt angle	Weekly	Check the tilt angle and roll angle via Modbus RTU output.	Any change in tilt position after the installation can affect the measurements due to the cosine response of the sensor.

6-2. Troubleshooting

Read the following in case of any sensor trouble. If any questions should remain, please contact EKO for further technical support.

Table 6-3. Troubleshooting in field

Failure	Action
There is no output.	Make sure that the sensor is properly connected, and type of power supply and voltage values are appropriate. Also check the communication settings [i.e. port, baud rate, converter ID] are appropriate.
Output value is too low	The glass dome maybe soiled with rain or dust. Clean the glass dome with demineralized water and soft cloth. The output may decrease over time. Recalibrate periodically.
Negative output signal during night-time.	Since the UV radiometer amplifies a very small signal internally, an offset of several mW/m^2 may occur depending on the installation environment.
Unusual noise	Check the shield connection and make sure it is connected securely. Make sure if the output cable is not shaking from the wind; take necessary measure by fixing or lining the cables through conduit. Check for any objects, which emit electromagnetic wave around the instrument and or cable.
4-20mA and 0-1V output outside range Example) 2mA output when using 4-20mA. The fluctuation of measured current is large.	Check the signal cable connection and make sure it is connected securely. Note that the appropriate ground wire connection method for this product may differ depending on the type of data logger and measurement environment. Select an appropriate ground wire connection method for this product according to the type of data logger and measurement environment.

Table 6-4. Troubleshooting Hibi

Failure	Action
No connection with PC	Make sure that the sensor is properly connected, and power supply and voltage levels are appropriate. Also check the communication settings [i.e. port, baud rate, converter ID] are correct.
No communication with USB cable	<p>If no COM port shows up when Hibi software is started.</p> <ul style="list-style-type: none"> - Reconnect the USB converter and refresh to search new COM devices - Check for COM port settings in Windows settings - Install an appropriate driver
Settings changes not saved to UV radiometer	<p>Make sure that the sensor is properly connected, and power supply and voltage levels are appropriate. Also check the communication settings [i.e. port, baud rate, converter ID] are correct.</p> <p>Power off/on the UV radiometer, some of the setting are effective after power off/on.</p>

7. Specifications

7-1. Specifications

1. UV radiometer Specifications

This product is calibrated to the sunlight spectrum, and is not suitable for measurement of artificial light sources, etc.

Table 7-1. UV radiometer specifications

Item	MS-10S	MS-11S
Measurement range	0 to 150 W/m ²	0 to 10,000 mW/m ²
Resolution	0.1 (W/m ²)	0.1 (mW/m ²)
Wavelength range for measurement	315-400nm	280-315nm
Spectral error	< 10%	< 20%
Non-linearity	<1%	
Temperature response	<±1% (-20 to +50°C)	
Cosine response	<±5% (0 to 70°)	
Response time	< 0.2 s	
Viewing angle	2π (sr)	
Operating temperature ^[1]	-40 to +80°C (Guaranteed accuracy temperature range: -20 to +50°C)	
Leveling accuracy	0.1 °	
Inclination sensor accuracy	<±1°	
Humidity sensor accuracy	±2%RH (Nominal value)	
Temperature sensor accuracy	±0.5°C (Maximum Tolerance)	
Protection class (IP code)	IP67 equivalent (IEC60529, JIS C0920)	
Weight	0.45kg	
Surface treatment	Anodized aluminum (anodic oxidation treatment)	
Output cable (O.D.)	AWG22 0.3mm ² x 5 cores (φ5.3mm)	
Output cable terminal	Pin terminal (0.3-9.5)	
Output signal ^[2]	1) Modbus RTU (default) 2) 4-20mA (default) 3) 0-1V (When an external 100Ω precision resistor is used) 4) SDI-12 ^[3]	
Supply voltage	<u>Operation mode</u> Modbus : 4-20mA : 0-1V : SDI-12 ^[3] :	<u>Voltage Range</u> 5Vdc±5% or 8 to 30Vdc±10% 8 to 30Vdc±10% 8 to 30Vdc±10% 9.6 to 16Vdc
Recommended load resistance (4-20mA / 0-10mA)	<u>Supply voltage</u> 8 to 15V : 15 to 24V : 24 to 30V :	<u>Recommended load resistance</u> 100 to 250Ω 250 to 500Ω 500Ω
Power consumption	<u>Operation mode</u> Analog output : Digital output :	<u>Power consumption</u> < 0.7 W < 0.2 W

[1] When the instrument is used in the ambient temperature exceeding the accuracy assurance temperature range, the measurement error may increase.

[2] Sensor setting can be changed by connecting the sensor to a PC (Use the USB cable (option)) and download the free "Hibi" configurator software from the EKO website.

[3] SDI-12 output is only supported by MS-10S/11S with the following product serial numbers.

MS-10S: UVA22001~UVA22023, EX22234.01~EX22392.02

MS-11S: UVB22001~UVB22017, EX22166.17~EX22392.05

Table 7-2. Power consumption supply Voltage specific

	5V DC	12V DC	24V DC	Remarks
During stand-by	75mW (Approx. 15mA)	90mW (Approx. 7.5mA)	110mW (Approx. 4.5mA)	-
Modbus RS485	170mW (Approx. 34mA)	180mW (Approx. 15mA)	190mW (Approx. 8mA)	Peak value during communication
4-20mA output	-	300mW (Approx. 30mA)	640mW (Approx. 27mA)	Apply the shunt resistor 250 Ω and 20mA output
0-1V output	-	300mW (Approx. 30mA)	640mW (Approx. 27mA)	Apply the shunt resistor 100 Ω and 10mA output

7-2. Dimensions

1. MS-10S/11S

Table 7-3. Dimensions

	MS-10S / MS-11S
A. Fixing Hole Pitch	65 mm
B. Body Height	73 mm
C. Levelling Screw Height	16 mm
D. Width [including Sun screen/Cover]	Φ96 mm
E. Overall Height [approx.]	101.5mm

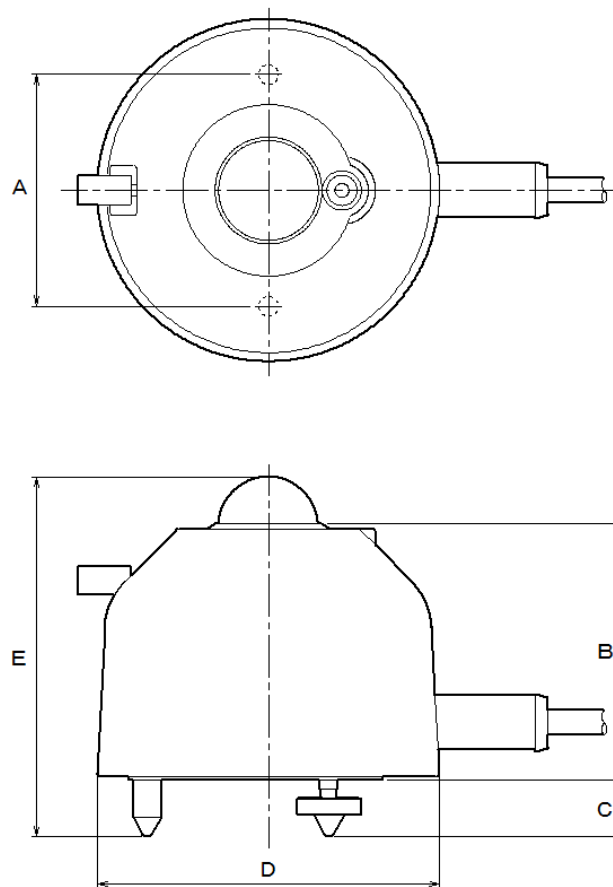

Figure 7-1. External Dimensions

7-3. Output Cables

See [5-2. Setup, 5-3. Wiring] for instruction

1. MS-10S / MS-11S

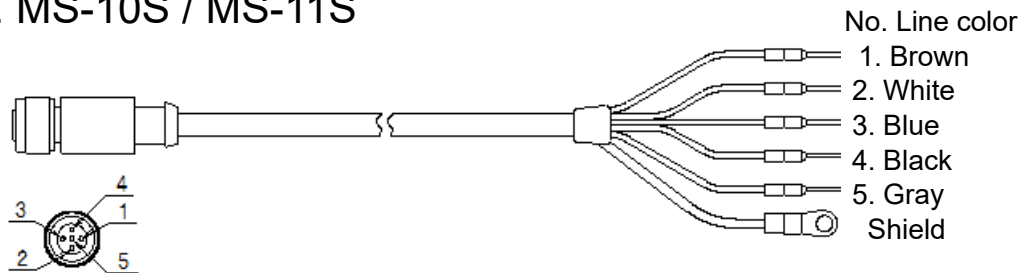

Figure 7-2. Output Cables

Different length (10m standard, 20m / 30m / 50m optional).

Table 7-4. Color Codes of cable

No.	Wire Color	4-20mA	Modbus	0-1V ^[1]	SDI-12 ^[2]
1.	Brown (+)	8 to 30VDC (+)	5VDC (+) or 8 to 30VDC (+)	8 to 30VDC (+)	12VDC (+)
2.	White (-)	4~20mA (-) / GND	Vcc GND / RS485 GND	0~10mA (-) / 0-1V (-) / GND	Vcc GND
3.	Blue (+)	---	RS485 (+)	---	SDI-12 Data (+)
4.	Black (+)	---	RS485 (-)	---	---
5.	Gray (+)	4~20mA (+)	---	0~10mA (+) / 0-1V (+)	---
Shield	Shield	FG	FG	FG	FG

[1] When selecting 0-1V output, a precision resistor is required separately.

[2] SDI-12 output is only supported by MS-10S/11S with the following product serial numbers.

MS-10S: UVA22001~UVA22023, EX22234.01~EX22392.02

MS-11S: UVB22001~UVB22017, EX22166.17~EX22392.05

2. EKO Converter Cable (Option)

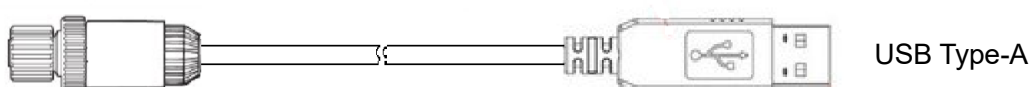

Figure 7-3. EKO Converter cable

7-4. Accessories List

Table 7-5. Accessories List

Option Items	Description
Output cable ^[1] ^[2]	Cable Length: 10m, 20m, 30m, 50m Terminals: Fork Terminals, Round Terminals, Pin Terminals
Ventilation Unit with Heater	MV-01 ventilator and heater
EKO Converter Cable	Converts from RS485 to USB for the communication with MS-10S/11S and allows to connect to PC via USB terminal. Cable Length:5m

[1] The standard cable length for the MS-80SH is 10 m.

[2] When using the optional cable, a power supply voltage of 24VDC or higher is recommended.

A-1. Radiometric Terms

Table A-1. Definitions of Terms

Response time	Time required for the output of the ultraviolet radiometer to reach 95%.
Non-linearity	Difference between the output value and the theoretical value for linearly varying light intensity
Directional response	Difference between the output value and the theoretical value for light incident from zenith angles of 0 to 70°.
Spectral error	The maximum spectral mismatch error of the UV radiometer with respect to the spectral irradiance at AM1.5 and AM5 under multiple atmospheric conditions on a clear day, relative to the standard spectral irradiance of AM1.5 as defined in IEC60904-3: 2016 Photovoltaic devices "Measurement principles for terrestrial photovoltaic (PV) solar devices with reference spectral irradiance data".
Temperature response	Output error relative to the output at 20°C when irradiating light at a constant intensity and varying the ambient temperature from -20 to +50°C.

A-2. Software (Hibi)

'Hibi' means 'day by day' in Japanese, and with this software, users will be able to visualize detection signals, set communication parameters, and rapidly troubleshoot any issues from day one. You can change the settings of the MS-10S/11S using this software downloadable from the EKO website (MS-10S/11S product page) and the optional USB cable.

1. Software Installation

Follow the steps below to install "Hibi" configurator software.

- 1) Download the latest version of the "hibi.zip" file [Compressed file: Zip format] from MS-10S/11S product page on the EKO website.
- 2) Unzip "hibi.zip" file and check that the "setup.exe" file exists.
- 3) Run the "setup.exe" file to install "Hibi" configurator software.

2. Hardware Preparation

After the software is installed, connect the MS-10S/11S with the PC to change the setting.

- 1) After installing the software, connect the USB connector of "RS485/USB Converter cable" to the PC.
- 2) Connect the ends of the signal cable of MS-10S/11S to the communication terminal of "RS485/USB converter".
- 3) Connect the power lines of the signal cable to the power supply (DC5V or 8 to 30V), and turn on the power supply. (Refer to Figure A2-1.)

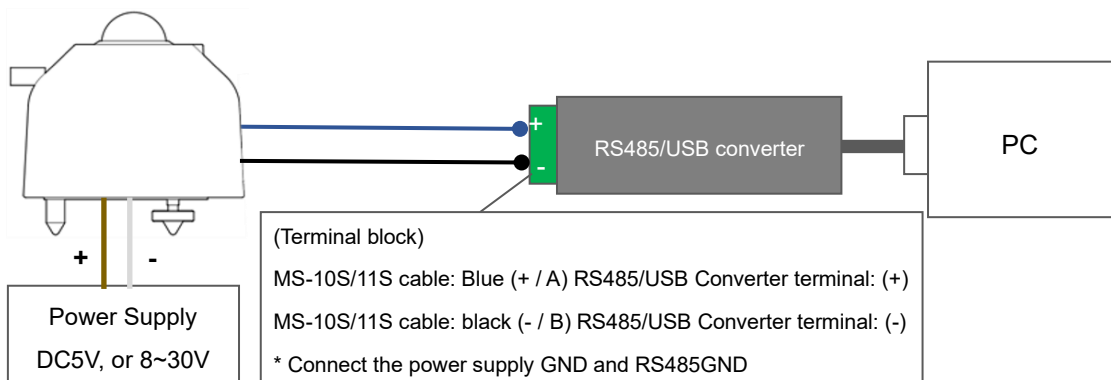

Figure A2-1. Hardware preparation

If you use the optional "EKO Converter cable", you can install it simply by connecting the cable to sensor the main unit. Power for the MS-10S/11S can be supplied via USB. (See Figure A2-2).

* This conversion cable is for installation, so please avoid using it outdoors for a long time. Because the ground wire is not connected, surges can damage your PC during a lightning strike.

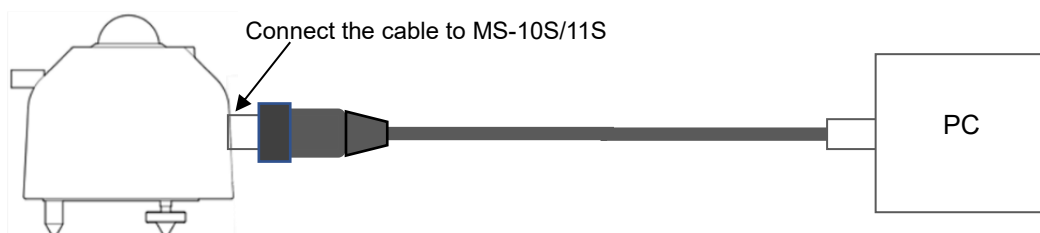

Figure A2-2. Using "EKO Converter cable"

3. Software

Start the “Hibi” software and make the required settings.

- 1) Start “Hibi” software. (Launch the software from “hibi.exe” located in the shortcuts or installation folder.)
- 2) After the software starts, the "Welcome" window appears.



Figure A2-3. Welcome window

- 3) Automatic connection

When using the “Auto-connect” function to connect MS-10S/11S with the “Hibi” software, select the COM port that the RS485/USB converter cable is connected to.

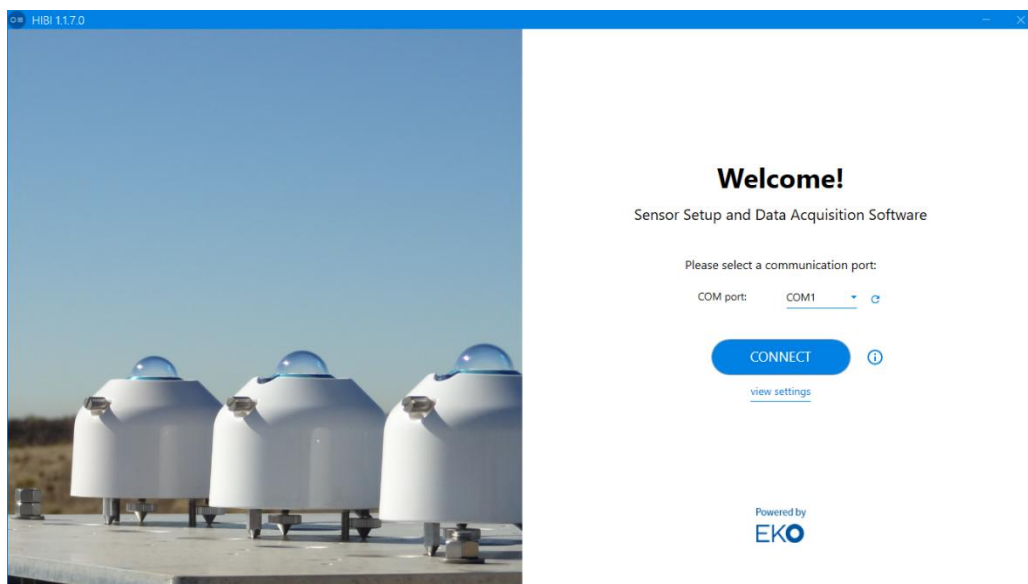

Figure A2-4. Com port select

Click “Select” of “COM port:” on the startup screen, and select the COM port number assigned to the RS485 / USB conversion cable from the displayed COM port numbers.

If you can't find a selectable COM port, click the Refresh button and click Select again to try again.

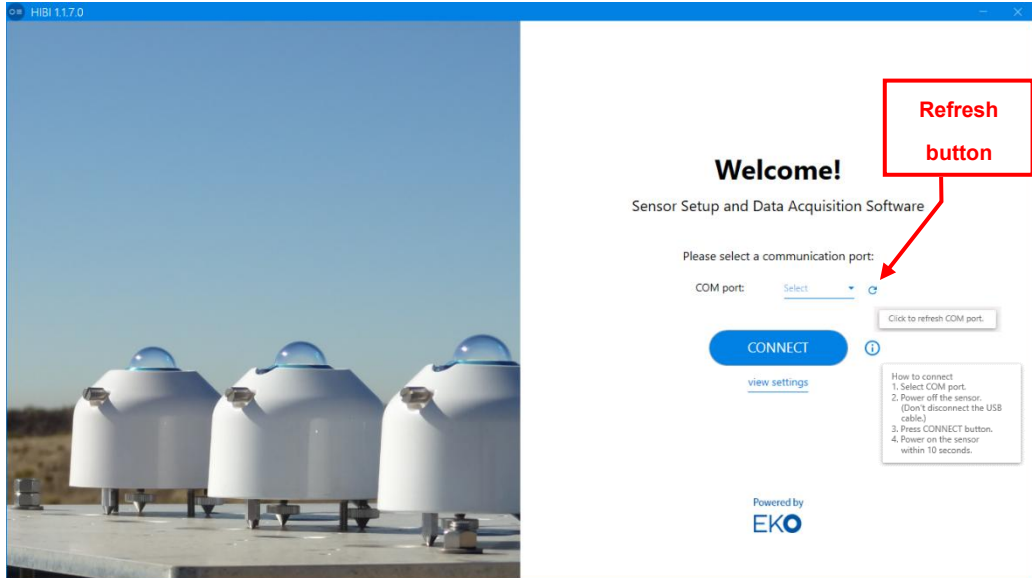

Figure A2-5. Com port select

Check that the power supply of the main unit is "OFF". Then, click "CONNECT" button.

If the COM port is not recognized, press the refresh button and try again.

Power on the MS-10S/11S within 10 seconds once the "Connecting your sensor" message appears.

When using the "EKO converter cable", connect the cable to the MS-10S/11S within 10 seconds after pressing the "CONNECT" button, and communication will start automatically.

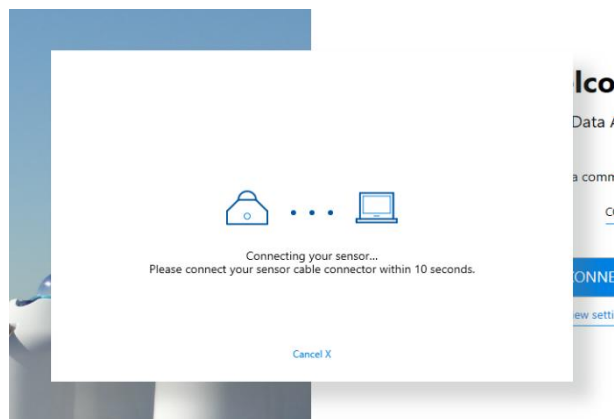

Figure A2-6. Connecting screen

When the connection is completed, the window automatically switches to the "Dashboard" window. In the upper-right corner of the display changes to "UV radiometer Connected".

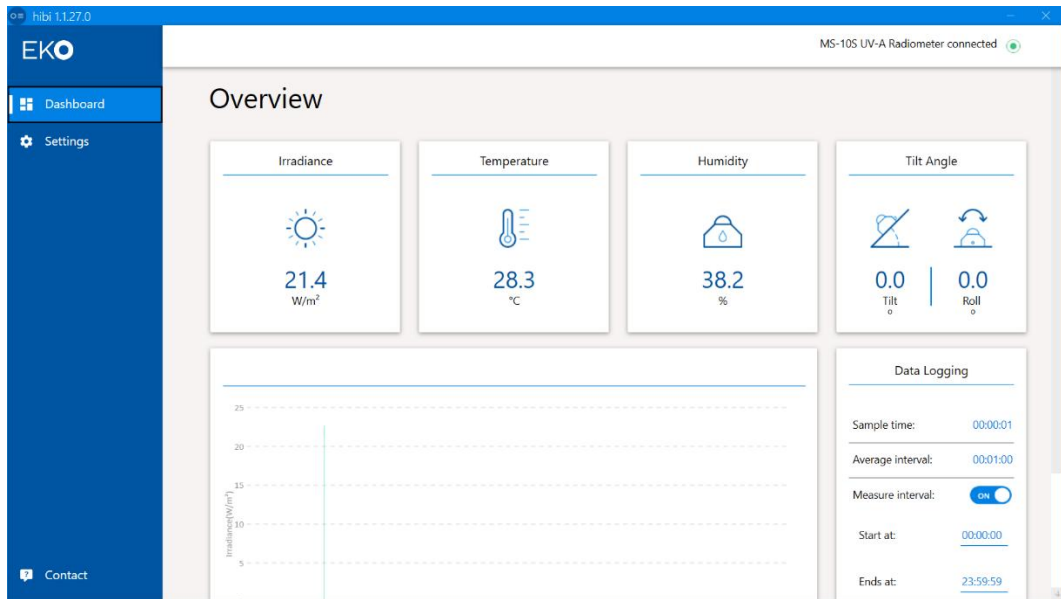

Figure A2-7. Dashboard

If the connection fails, the screen returns to the "Welcome" screen and "CONNECTION FAILED" is displayed.

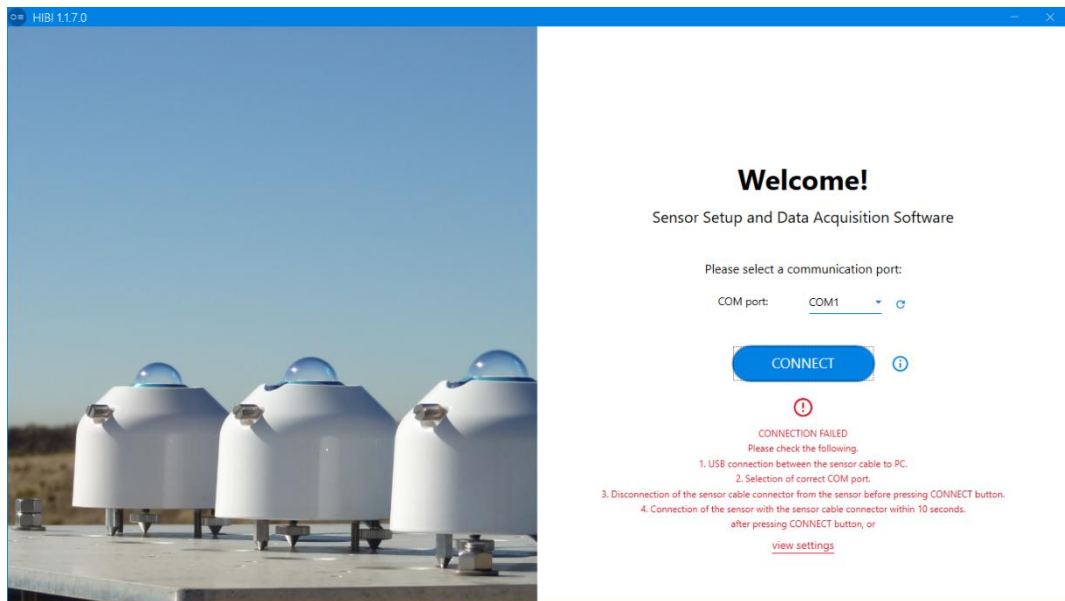

Figure A2-8. CONNECTION FAILED

Make sure the connection settings are correct. To perform the "Auto-connection" again, turn off the power of the MS-10S/11S, select "COM port", and then click "CONNECT".

For manual connections, click "View settings" at the bottom of "CONNECTION FAILED" to go to "Settings screen". (As for how to set and connect by "Manual connection", refer to the procedures (4) Manual connection) from the next section.

4) Manual connection

After turning on the power of the MS-10S/11S, click "CONNECT" without selecting "COM port".

Clicking "view settings" at the bottom of the "CONNECTION FAILED" screen moves to the "Settings" screen. (The same screen appears even when the "Auto-connection" fails. To perform manual connection, set and connect using this procedure.)

After that, click the "CONNECT" button in Connection status.

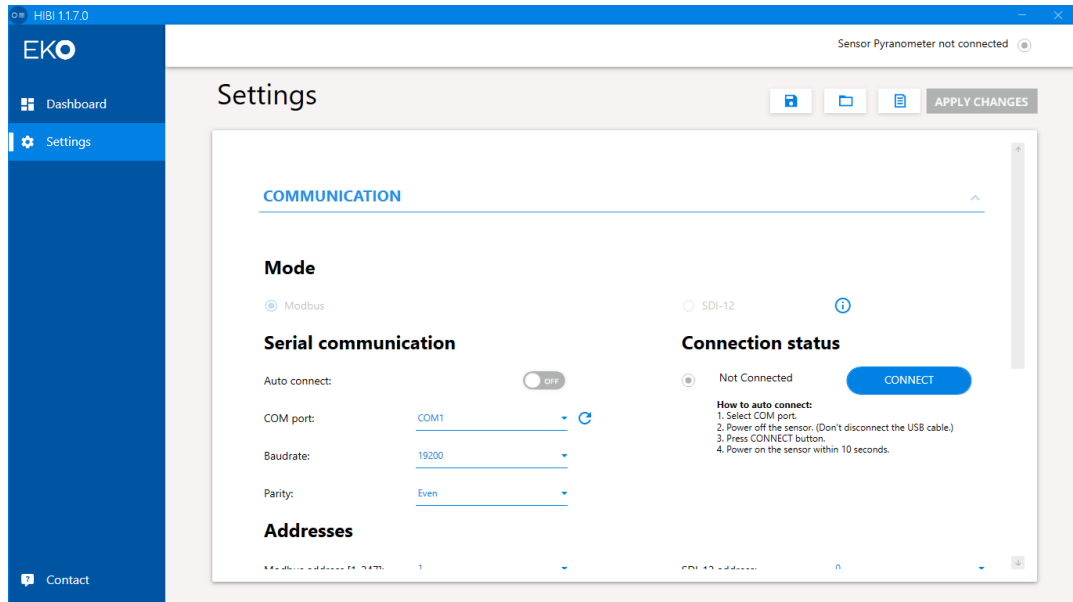

Figure A2-9. Manual connection

When the connection is completed, "Connected" is displayed.

"XXXX UV radiometer Connected" is also shown in the upper-right corner of the display.

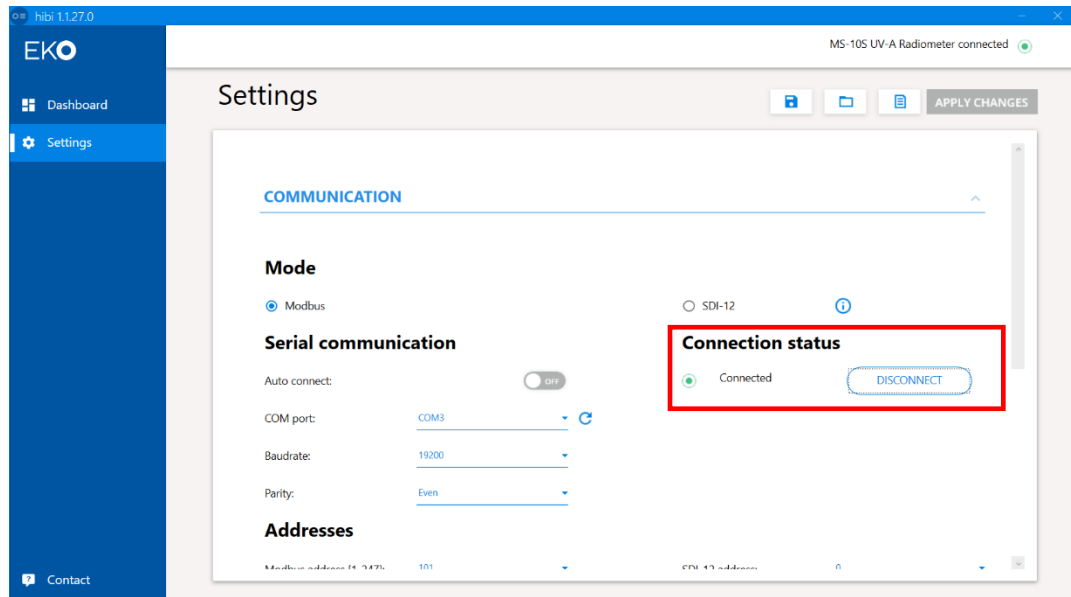

Figure A2-10. Disconnect appear

When the connection fails, the "Oops..." screen is displayed with the cause of the connection failure.

When connection fail appears

Check that the cable connection, COM port and the communication requirements are correct.

When changing the connection condition after successful connection, set "COM port", "Baud rate" and "Parity" in the "Serial communication" setting of the "COMMUNICATION" items and set "Modbus address [1-247]" and "Register Type" in the "Addresses" setting.

After entering the settings, click "APPLY CHANGES"
A confirmation window will be displayed.

Click "YES, SAVE" to make the settings for the MS-10S/11S.

The settings in "Settings" can be saved / read / exported to CSV files.

Click the button with icons in the upper-right corner of "Settings" window.

- "Save" button: Save the settings.
- "Read" button: Read out the settings.
- "Output" button: Output the settings to CSV file

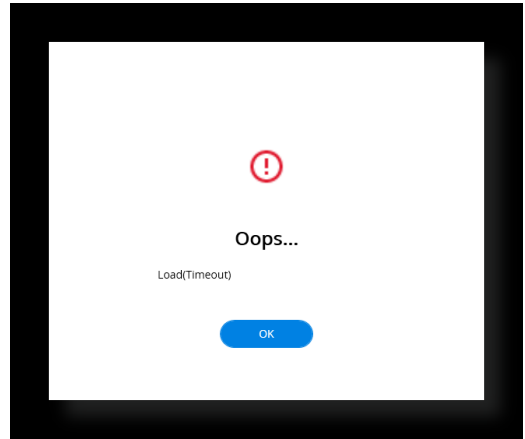

Figure A2-11. Oops screen

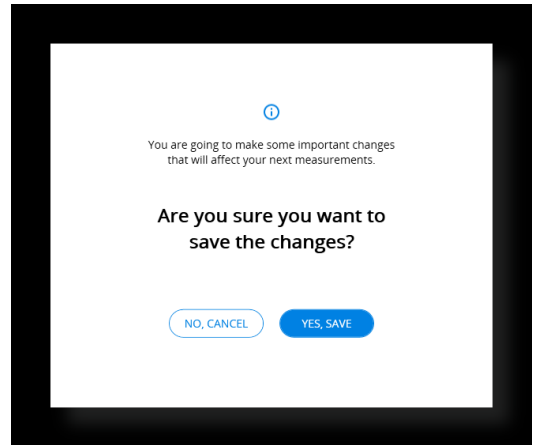

Figure A2-12. Apply changes screen

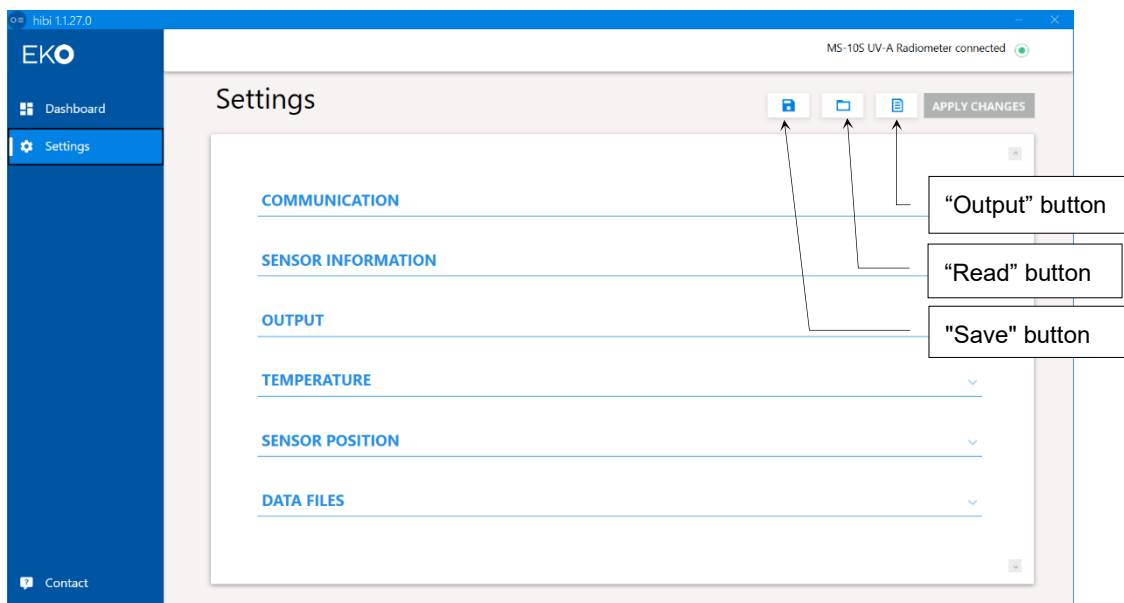

Figure A2-13. Settings screen

5) Setting items

1. COMMUNICATION setting items

Item Name	Setting contents	Setting range
Mode	Modbus	Switch to Modbus RTU interface (Default)
	SDI-12 [*]	Switch to SDI-12 interface.
Serial communication	Auto search	OFF/ON: Manual/Auto-connect
	COM Port	COM1 to COM256
	Baud rate	2400 / 4800 / 9600 / 19200 / 38400 / 115200bps
	Parity	Even / Odd / None
Addresses	Modbus address [1-247]	1 to 247 (last 2 digits of serial number is default address, 100 when "00")
	Register Type	S-series / M-series/ SMP-series/ SRD-series
	SDI-12 address [*]	0 to 9 / A to Z / a to z
Connection status	---	Connected / Disconnect

[*] SDI-12 output is only supported by MS-10S/11S with the following product serial numbers.

MS-10S: UVA22001~UVA22023, EX22234.01~EX22392.02

MS-11S: UVB22001~UVB22017, EX22166.17~EX22392.05

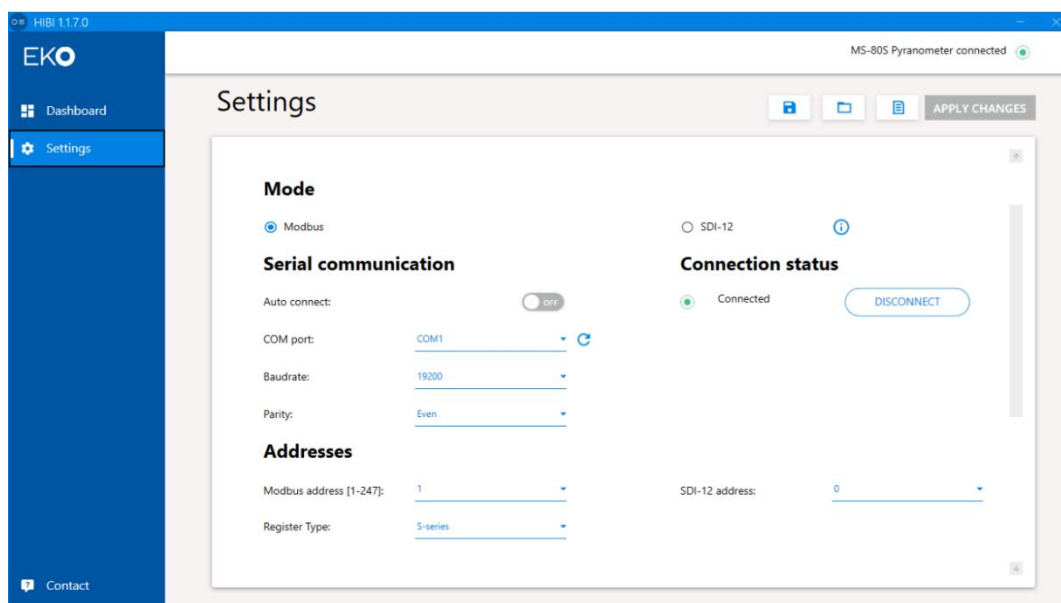

Figure A2-14. Communication setting screen

2. "SENSOR INFORMATION" setting items

Item Name	Setting contents	Setting range
Model information	Model	Model name registered in the MS-10S/11S (cannot be changed)
	Serial number	Serial number registered to the MS-10S/11S (cannot be changed)
	MFG. date	Date of manufacturing (cannot be changed)
	Firmware version	Firmware version of MS-10S/11S (cannot be changed)
	Hardware version	Hardware version of MS-10S/11S (cannot be changed)
Calibration	Calibration date	Calibration date and time: Registered at the time of calibration by the manufacturer, but can also be registered by the user.
	Sensitivity [$\mu\text{V}/\text{W}/\text{m}^2$] or [$\mu\text{V}/\text{mW}/\text{m}^2$]	Sensitivity constant: Registered at the time of manufacturer calibration, but can also be registered at the user side.

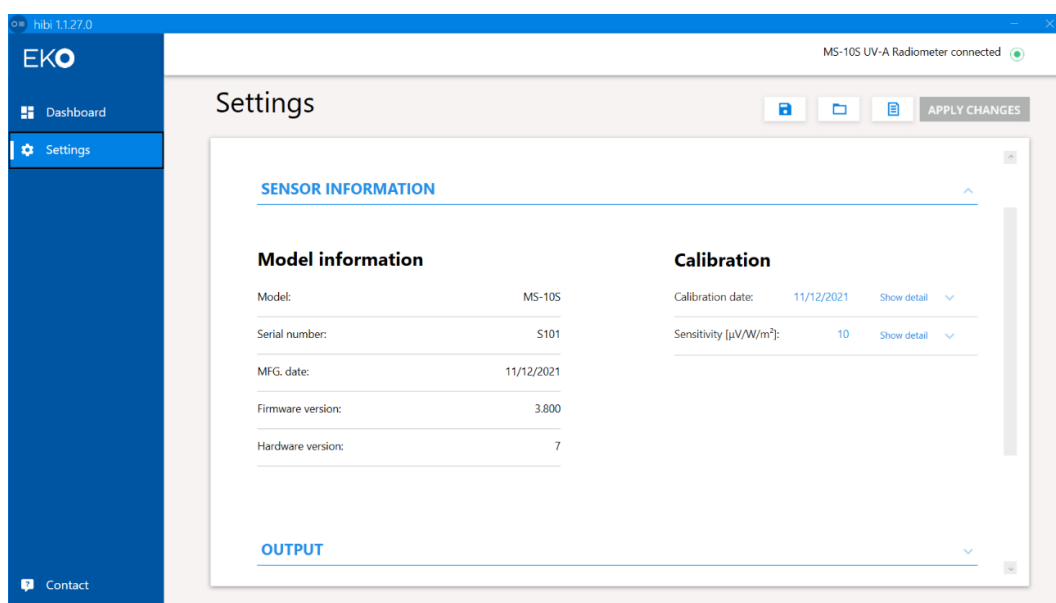

Figure A2-15. Sensor information settings

3. "OUTPUT" setting items

Item Name	Setting contents	Setting range
Analog output	Enable analog output	Analog output OFF/ON (selected with the radio button) Either 4-20mA or 0-1V power can be selected. * Default is 4-20mA.
	4-20mA	Current[mA] / Irradiance[W/m ²] or [mW/m ²]: Setting of minimum and maximum irradiance [W/m ²] or [mW/m ²] corresponding to the output.
	0-1V	Voltage[V] / Irradiance[W/m ²] or [mW/m ²] : Setting of minimum and maximum irradiance [W/m ²] or [mW/m ²] corresponding to the output.
	Resistance [ohm]	Load resistor value for calculating output current at 0-1V output

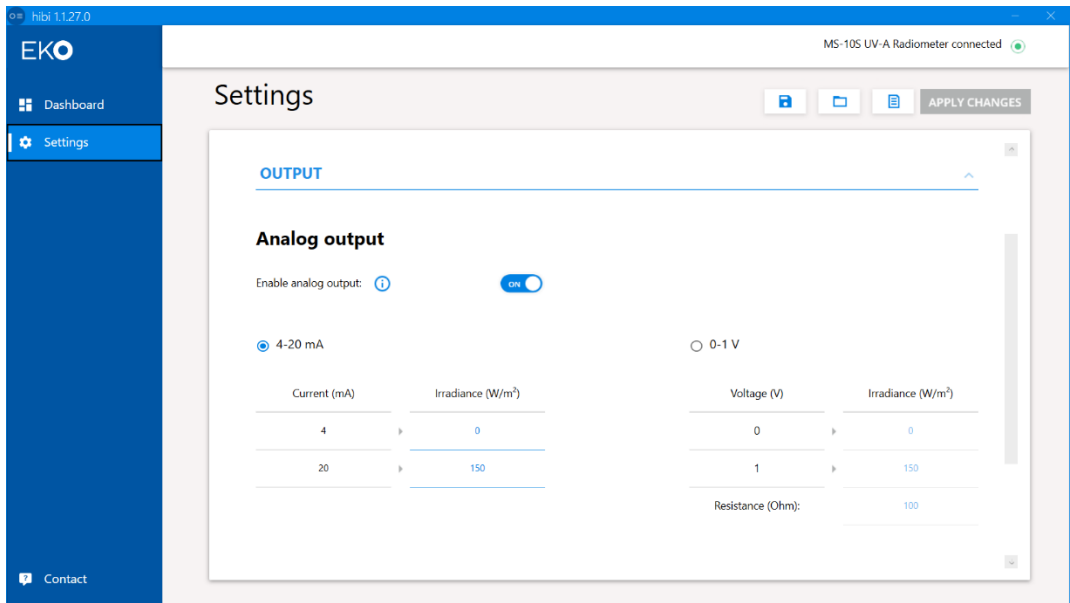

Figure A2-16. Analog settings screen

4. "TEMPERATURE" setting items

Item Name	Setting contents	Setting range
UNIT	Preferred unit (temperature unit setting)	°C -Celsius / °F -Fahrenheit / K-Kelvin

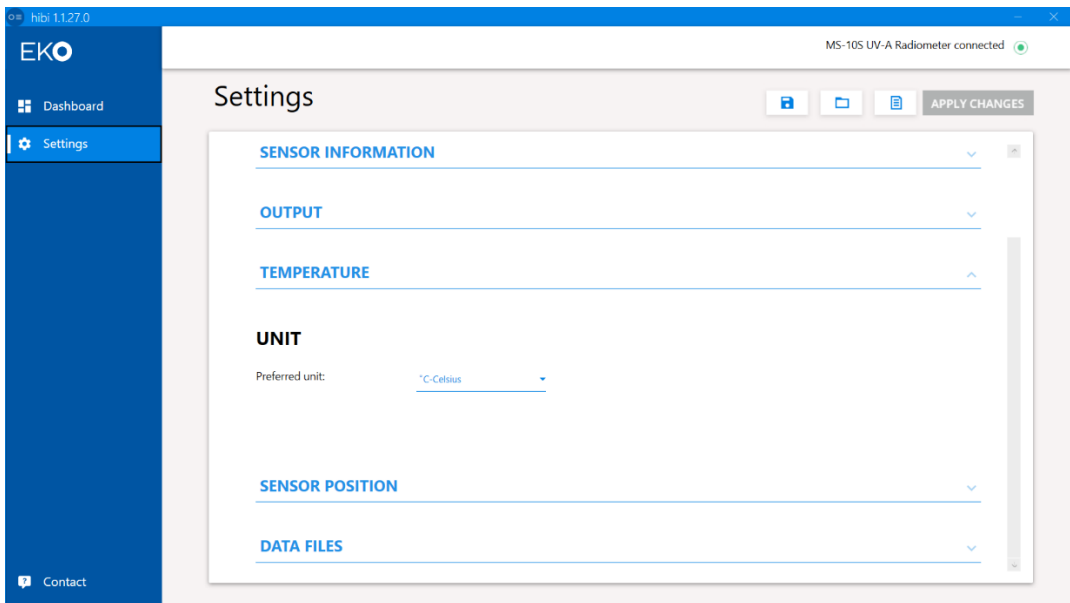

Figure A2-17. Sensor settings screen

5. "SENSOR POSITION" setting items

The sensor position can be measured in two different planes (X, Y).

<Tilt (X axis)> (180° to 0) and (0 to -180°)

<Roll (Y axis)> (180° to 0) and (0 to -180°)

The tilt and roll angles are relative to the calibrated X and Y axis of the sensor and surface mounting plane X' and Y'. When the sensor is positioned in the same plane $X = X'$ and $Y = Y'$, the measured angles X and Y represent the corresponding plane of installation X' and Y'.



Clicking "ZERO ADJUSTMENT" allows you to adjust Tilt (X axis) and Roll (Y axis) of Tilting items using the present tilt angle as 0°. The spirit vial can be used as a reference to readjust the tilt and roll position. For MS-10S/11S X and Y position is factory calibrated.

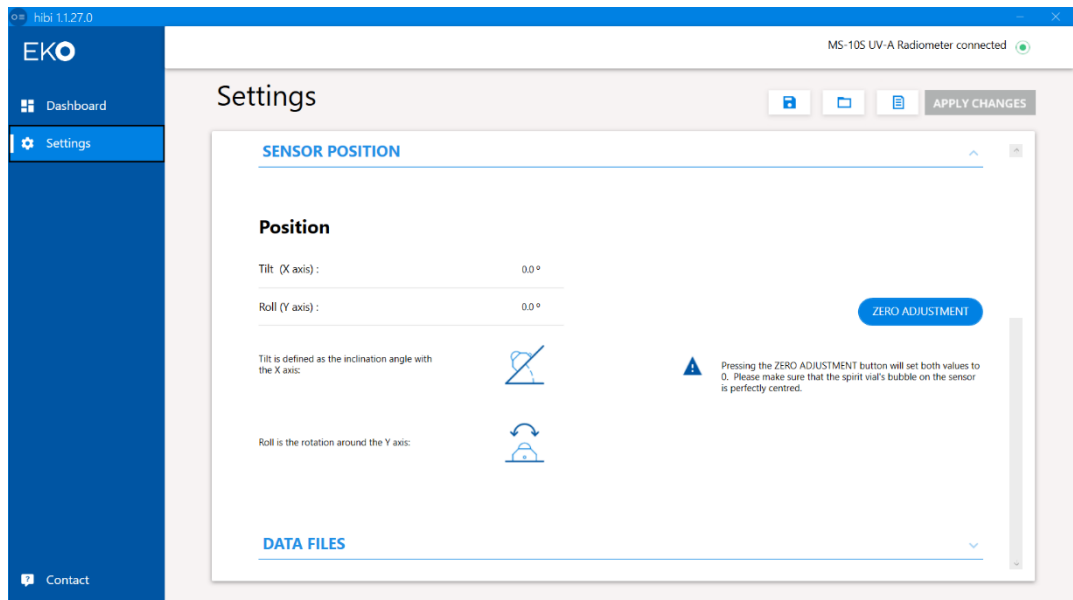

Figure A2-18. Sensor Position setting

6. DATA FILES setting items

[Measurements]

<Save file to> Enter the name of the measurement data storage folder.

Default file name format : SensorYYYYMMDDhhmmss.csv

[Sensor settings]

<Save file to> Enter the name of the setting file storage folder.

Default file name format : MS-10S/11S_serialnumber_0_YYYYMMDDhhmmss.ini

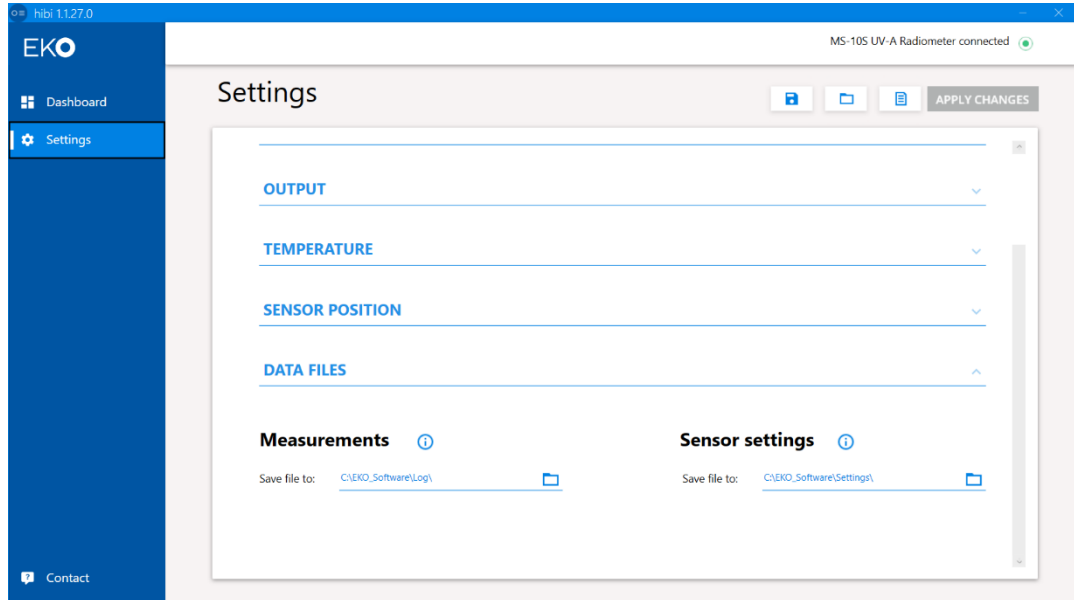

Figure A2-19. Data Files setting

6) Measurement (Dashboard)

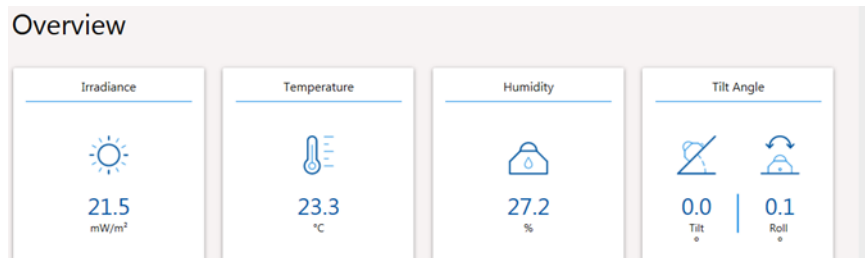

Figure A2-20. Dashboard screen

[Overview]

- Measurement data of irradiance, temperature, humidity, and tilt angle are read from MS-10S/11S every 1 second and displayed.

<Irradiance> Irradiance measurement data. Unit: MS-10S is W/m², MS-11S is mW/m².

<Temperature> Internal temperature measurement data.

Unit: selected from "°C (Celsius)", "°F (Fahrenheit)" or "K (Kelvin)". (°C: default)

<Humidity> Humidity measurement data (Unit: "%RH")

<Tilt Angle> Tilt (X axis angle) and Roll (Y axis angle) data

[Real-time measurement view]



Figure A2-21. Real-time measurement view

<Real time measurement-Irradiance>

- Display measured irradiance data in a graph (1-second update).
- Drag the graph to change the horizontal axis position and use the mouse wheel to zoom in or out on the desired area.
- The time range of the graph is 00:00:00 to 23:59:59.
- Clicking "Back to default" resets the change of the setting of the graph.

<Data Logging>

Logging function of measurement data

"Sample time:" Set the logging interval for measurement data.

Setting range: 00:01~01:00 (1 sec to 1 min)

"Average interval:" Set the logging interval for averaged measurement data.

Setting range: 00:01~01:00 (1 sec to 1 min)

"Measure intervals:" Set the time interval for data logging.

By checking "Continue next days", it is also possible to keep setting after the next consecutive days.

"Start at:" Set the start time for data logging.

"Ends at:" Set the end time for data logging.

* Setting across the day is not possible. The start time must be earlier than the end time. (Start time < End time)

"LOG DATA buttons:" Click to start logging measurement data.

When "STOP" is clicked while measurement data is being logged, logging stops.

7) Contact (Contact)

When you click the “Contact” button, the contact page on [EKO Instruments] website appears in the Browser.

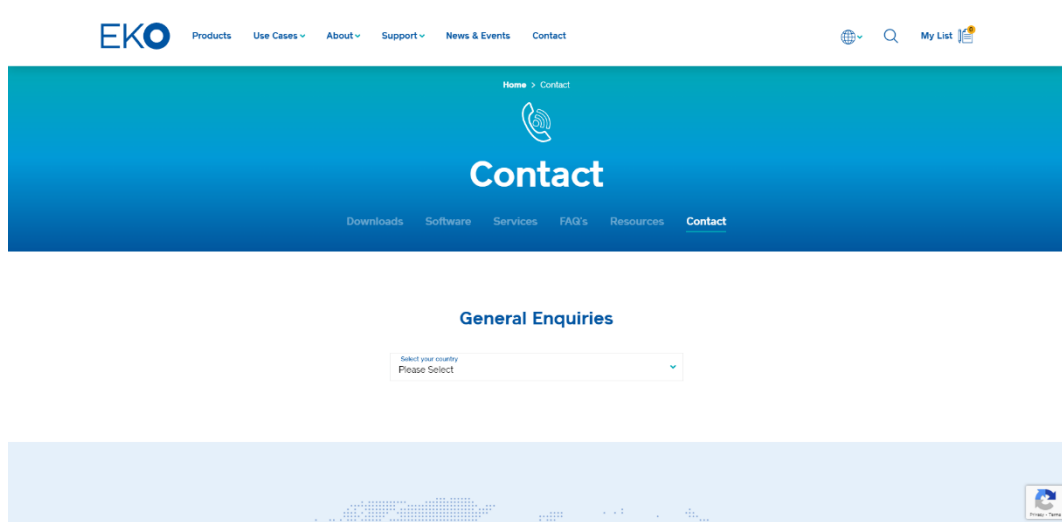

Figure A2-22. Contact page @EKO website

8) Sensor internal humidity abnormality alert

Hibi has a function to monitor the relative internal humidity of the UV radiometer at all times. When the internal relative humidity exceeds the standard value due to external failure or deterioration of drying agent over time, Hibi judges it to be abnormal and displays an alert. If a UV radiometer is left as is after the alert, the possibility of a problem such as condensation inside the UV radiometer glass dome will increase, so please contact EKO.

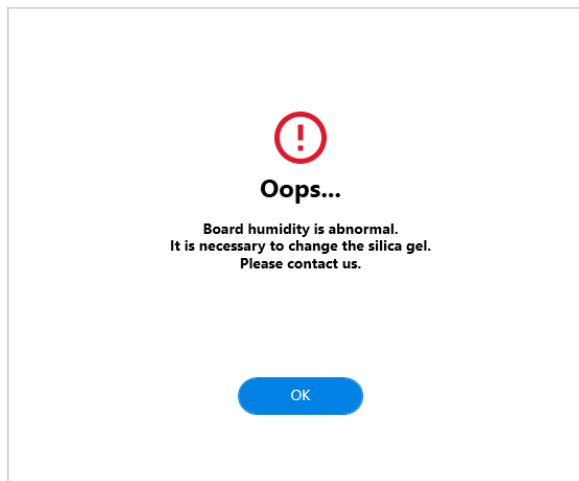

Figure A2-23. Sensor internal humidity abnormality alert

9) Recalibration recommendation notice

If Hibi detects that 2 years (730 days) have passed since the initial calibration date, a recalibration recommendation notice will appear.

If the above notification is displayed, please contact EKO for recalibration.

* In the case of leap years, notifications will be displayed from the day before.

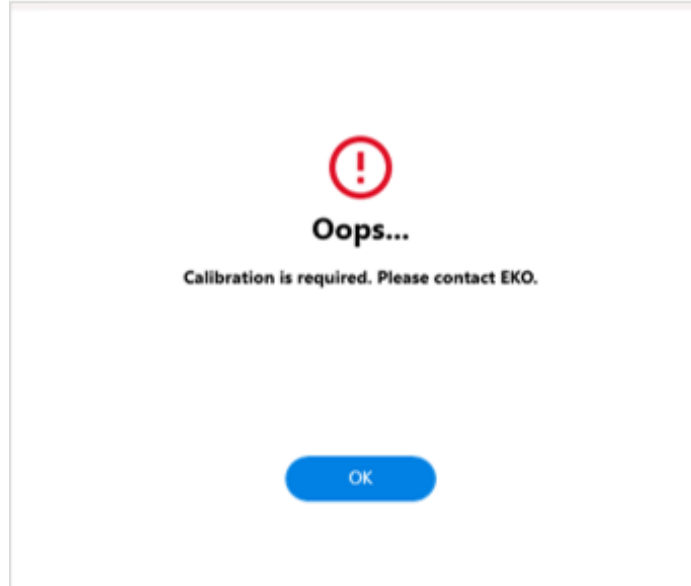

FigureA3-24. Recalibration recommendation notice

10) Exiting the software (Hibi)

To exit Hibi, click the "X" in the upper-right corner of the window.

A-3. Communication Specifications (Modbus RTU)

A3-1. Outlines

- This device is compatible with Modbus RTU*. ASCII modes are not supported.
(* This is an open protocol for serial communication developed by Modicon.)
 - The initial setting of the communication interface is Modbus mode. To use the SDI-12^(*) mode, change the settings from “Hibi” software. After changing the setting, turn the power off and then on again to operate with SDI-12^(*). To return to Modbus mode again, change the setting from “Hibi” software.
 - It corresponds to RS485, half-duplex and double-wire multi-drop networks.
- [*] SDI-12 output is only supported by MS-10S/11S with the following product serial numbers.
- MS-10S : UVA22001~UVA22023、EX22234.01~EX22392.02
- MS-11S : UVB22001~UVB22017、EX22166.17~EX22392.05

The communication specifications are as follows.

Table A3-1. Modbus RTU communication protocol

Optional item	Remarks
Electrical specifications	EIA-485
Connection form	Multi-drop method (1 for Master, 31 for Slave, 32 for total)
Communications protocols	Modbus RTU ^(*) (Slave)
Communication speed baud rate	2400, 4800, 9600, 19200 , 38400, 115200 bps
Data length	8 Bit
Stop bit	1 bit / 2 bit ^(*)
Parity bit	None/Odd/ Even
Communication distance	Max.1000m (ideal value)
Error detecting system	CRC-16

*1: An open protocol developed by Modicon for serial communication.

*2: The value of the stop bit is determined automatically by the parity bit setting.

A3-2. Function code

- There is no distinction between Coil and Discrete Input addresses.
- There is no distinction between Holding Register and Input Register addresses.
- Coil, Discrete Input, Holding Register, Input Register addresses start from “0”.

Table A3-2. Supported Function Codes

Function code (hexadecimal)	Function
0x01	Read Coils
0x02	Read Discrete Inputs
0x03	Read Holding Registers
0x04	Read Input Register
0x05	Write Single Coil
0x06	Write Single Register
0x10	Write Multiple Registers

A3-3. Communication specification

- The address range can be used from 1 to 247.
- The maximum frame size that can be communicated at a time is 256 bytes (maximum read registers: 125, maximum write registers: 123).
- The baud rate (bit/sec) can be selected from 2400, 4800, 9600, 19200, 38400 and 115200.
- Parity can be selected from “Even”, “Odd” or “None”.
- The bit width is 8 bits, the stop bit is 1 bit when parity is present, and 2 bits when parity is absent.
- If the address and communication settings are changed, the equipment must be restarted.

Table A3-3. Communication setting

Setting No.	Bit rate	Parity
0	2400	None
1	2400	Even
2	2400	Odd
3	4800	None
4	4800	Even
5	4800	Odd
6	9600	None
7	9600	Even
8	9600	Odd
9	19200	None
10 (default)	19200	Even
11	19200	Odd
12	38400	None
13	38400	Even
14	38400	Odd
15	115200	None
16	115200	Even
17	115200	Odd

A3-4. Cable connection

- RS485 communication ground and the power ground are the same.

Be sure to connect the ground of RS485 communication interface to the power ground.

A3-5. Data format

Table A3-4. Data format to use.

Format	Abstract
U16	Unsigned 16bit Integer
S16	Signed 16bit Integer
U32	Unsigned 32bit Integer
S32	Signed 32bit Integer
F32	IEEE754 32bit floating point format
Str	ASCII characters string

- The byte order for communication is big endian.
 2byte values are sent in the order of H byte → L byte
 4byte values are sent in the order of H word → L word
 Character strings are sent in the order of 1 byte from the beginning.
 Allocation of each format is shown in the table below.

Table A3-5. Assignment of 8/16/32 bit value

8bit	0x12	0x34	0x56	0x78
16bit	0x1234(MSW)		0x5678(LSW)	
32bit	0x12345678			

Table A3-6. Assignment of 8/16 bits and F32

8bit	0x41	0x45	0x85	0x1E
16bit	0x4145(MSW)		0x851E(LSW)	
F32	12.345			

Table A3-7. Assignment of 8/16bit and Str

8bit	0x41	0x42	0x43	0x44
16bit	0x4142(MSW)		0x4344(LSW)	
Str	'ABCD'			

- Unless otherwise stated, the 32-bit register is in the order of high word (MSW) followed by low word (LSW).
 The following table shows the cases where 0x12345678 is assigned to address n of Modbus register.

Table A3-8. Relationship between 32-bit values and Modbus registers

32-bit value	0x12345678
Modbus register (address n)	0x1234(MSW)
Modbus register (n+1)	0x5678(LSW)

A3-6. Outline of 1 Holding/Input register map

- The register map starts from address 0.
- Registers No. 0 to 99 are read-only.
- Registers after No.101 can be read or written to.

A3-7. No. 0-49 Register details

- See in parentheses for the unit.
- Fixed value if the content is numeric.
- The blank space is not used. It is filled with zero in U16 format.

Table A3-9. No. 0-49 Register S-series type (default)

0	Model	U16	Model number of the transmitter. (MS-10S:0x0130, MS-11S:0x0131)
1	0	U16	Fixed value
2	Comp.Irr	F32	Corrected UV irradiance
3			Unit: MS-10S(W/m ²), MS-11S(mW/m ²)
4 to 13 are Reserve			
14	X-axis tilt angle	F32	X-axis component of the tilt angle
15			Unit: (°)
16	Y-axis tilt angle	F32	Y-axis component of the tilt angle
17			Unit: (°)
18	Raw.Irr	F32	UV irradiance before correction
19			Unit: MS-10S(W/m ²), MS-11S(mW/m ²)
20	ADmV	F32	Sensor output voltage
21			Unit: (mV)
22	Internal temperature	F32	Temperature measured by the internal temperature sensor
23			Unit: (°C)
24	Internal humidity	F32	Relative humidity measured by the internal humidity sensor
25			Unit: (% RH)
26	Alerts for abnormal internal humidity of the UV radiometer	U32	Alerts for abnormalities in the internal humidity of the UV radiometer
27			Normal: 0, Abnormality occurs: 1
28 to 49 are Reserve			

A3-8. Measurement value register update cycle

- The sensor output and the tilt angle measurement value in the register are automatically updated.

The update cycle is about 110 msec. If the data read cycle is less than 110msec, the same data will be read multiple times. The data read cycle should be 110msec or more.

A3-9. Register details from No.50 to 99

- A fixed value of zero (U16) has been written to an address that is not used.
- The "EKO" character is written as the company name registration in register No. 96 and 97.

Table A3-10. Register No.50-95

50 to 95 are Reserve

Table A3-11. Register No.96-99

96	Company name (0,1)	Str	The company name in ASCII format "EKO" is read.
97	Company name (2,3)		Four "EKO" characters, three "EKO" characters and one space (0x20).
98	Firmware version	U16	Firmware version number.
99	Hardware version	U16	Various parts of hardware

A3-10. No. 101 or later registers

- Registers after No.101 are readable and writable, and values written are immediately reflected.
- To save the written data, use Discrete Coil shown below to save the data.
- The 2 registers, Modbus address (No.101) and serial communication setting (No.102) related to communication are not reflected in the operation after saving and rebooting.

Table A3-12. Register No.100-199

100 is Reserve			
101	Modbus Address	U16	Modbus slave address
102	Serial communication setting	U16	Set bit rate and parity, see Table A3-3. "Communication setting"
103 to 105 are Reserve			
106	Setting the analog outputs	U16	Analog current output setting, Table A3-14. "Analog output setting details"
107 to 130 are Reserve			
131	0-1V loading resistor	F32	Accurate load resistance value, default 100 Ω Used to calculate the output current in 0-1V mode.
132			
133	Irradiance (0-1Vmode 0V)	F32	Sets the radiance in 0-1V or 0V.
134			
135	Irradiance (0-1Vmode 1V)	F32	Sets the radiance in 0-1V or 1V.
136			
137	Irradiance (4-20mode 4mA)	F32	Irradiance intensity value at 4-20mA mode and output current of 4[mA] defaults to 0 [W/m ²]
138			
139	Irradiance (4-20mode 20mA)	F32	Irradiance intensity value at 4-20mA mode and an output current of 20mA defaults use 150[W/m ²] (MS-10S) or 10,000[mW/m ²] (MS-11S)
140			
141 to 161 are Reserve			
162	Date of manufacture	U32	Date of manufacture in YYYYMMDD format
163			
164	Serial number	U32	Serial number with 32-bit integer value (maximum value 4294967295) Enter the number part excluding the alphabet S.
165			
166	Sensor name (0,1)	Str	Sensor name according to ASCII format, up to 16 characters Null-terminated unless all 16 characters are used
167	Sensor name (2,3)		
168	Sensor name (4,5)		
169	Sensor name (6,7)		
170	Sensor name (8,9)		
171	Sensor name (10,11)		
172	Sensor name (12,13)		
173	Sensor name (14,15)		
174 to 181 are Reserve			

182	L.Coeff.k1	F32	Linear correction factor k1
183			
184	L.Coeff.k2	F32	Linear correction factor k2
185			
186	L.Coeff.k3	F32	Linear correction factor k3
187			
188	L.Coeff.k4	F32	Linear correction factor k4
189			
190	Cal.Date	U32	Calibration date in YYYYMMDD format
191			
192	Cal.Value	F32	Calibration value
193			MS-10S: $\mu\text{V}\cdot\text{W}^{-1}\cdot\text{m}^{-2}$, MS-11S: $\mu\text{V}\cdot\text{mW}^{-1}\cdot\text{m}^{-2}$
194 to 199 are Reserve			

Table A3-13. Register No.200-219

200	Cal.Date history0	U32	Calibration History, Date 0
201			
202	Cal.Value history0	F32	Calibration history, sensitivity constant 0
203			
204	Cal.Date history1	U32	Calibration History, Date 1
205			
206	Cal.Value history1	F32	Calibration History, Sensitivity Constant 1
207			
208	Cal.Date history2	U32	Calibration History, Date 2
209			
210	Cal.Value history2	F32	Calibration History, Sensitivity Constant 2
211			
212	Cal.Date history3	U32	Calibration History, Date 3
213			
214	Cal.Value history3	F32	Calibration History, Sensitivity Constant 3
215			
216	Cal.Date history4	U32	Calibration History, Date 4
217			
218	Cal.Value history4	F32	Calibration History, Sensitivity Constant 4
219			

Table A3-14. Analog output setting details

Analog output setting value	Operation modes
0	Output OFF
1	0-1V Mode
2	4-20 mA Mode

A3-11. Linear correction factor

- Calculate the UV radiometer output after linear correction using the following equation using the coefficient k1/k2/k3/k4 for the UV radiometer output V(raw) after temperature correction.
- Linear post-correction the UV radiometer output $V(L) = k1 + (k2 \cdot V(\text{raw})) + (k3 \cdot V(\text{raw})^2) + (k4 \cdot V(\text{raw})^3)$
- The default value is k2=1, k1=k3=k4=0, so $V(L)=V(\text{raw})$, and the raw value is used for the corrected UV radiometer output.

A3-12. UV irradiance after correction

- After the linear correction and temperature correction written above, using the sensitivity value **S** [$\mu\text{V}\cdot\text{W}^{-1}\cdot\text{m}^{-2}$] for the output voltage, according to the following equation, calculate the irradiance value.

$$\text{Corrected UV irradiance: } I(C) = V(L) \times 1000/S$$

*Since the unit of **V(L)** is millivolts, multiply it by 1000 to obtain the irradiance value.

A3-13. Outline of Coil / Discrete Input Registers

- Reboot the device and save the settings by writing a specified bit.
- Do not write to any Coil other than Reboot/Save.
- The readout is always zero.

A3-14. Register details

Table A3-15. Coil register

Addr	Parameter	R/W	Type
0	-	-	-
1	Reboot	W	Bit
2	-	-	-
3	Save	W	Bit
4	-	-	-
5	-	-	-
6	-	-	-
7	-	-	-

A-4. Communication specification (SDI-12)

A4-1. Abstract

- SDI-12 output is only supported by MS-10S/11S with the following product serial numbers.
MS-10S : UVA22001~UVA22023、EX22234.01~EX22392.02
MS-11S : UVB22001~UVB22017、EX22166.17~EX22392.05
- SDI-12 (Version:1.4) is supported.
- The initial setting of the communication interface is Modbus. To use the SDI-12 interface, change the settings from "Hibi" software. After changing the setting, turn the power off and then on again to operate with SDI-12 mode. To return to Modbus mode again, change the setting from "Hibi" software.
- When SDI-12 is enabled, the unit operates in "low power standby mode" with power consumption of approx. 2.5mA (at 12V) during non-communication.

A4-2. Communication specification

- The communication specifications of SDI-12 are as follows.

Table A4-1. SDI-12 Communication Specifications

Item	Description
Communications protocols	SDI-12 Version 1.4
Baud rate	1,200 bps
Data length	7bit
Stop bit	1
Parity bit	Even
Communication distance	Within 60 m

A4-3. Command list

- SDI-12 commands are listed below.
- The lowercase letter 'a' in the command list indicates SDI-12 address number.
- SDI-12 address number that can be set is 0-9, A-Z, a-z.

Table A4-2. SDI12 Commands

Command	Response	Description
?!	a<CR><LF>	Check the address number of the connected device. NOTE: If more than one device is connected, it will not function properly. Be sure to use the device alone.
a!	a<CR><LF>	Verify that the device with address number "a" is active.
aAb!	b<CR><LF>	Change the address number of the device with address number "a" to "b".
a!	Refer to the right section	Returns information. <Response example> "a14EKOINST_MS-10SV3220000001<CR><LF>" a: SDI-12 address 14: SDI-12 version (represents version 1.4) EKOInst: Company name (8 characters) MS-10S: Sensor model name (6 characters) V32: Sensor version (3 characters) 20000001: Serial number (8 characters)

aM!	a0001<CR><LF>	Request the device with address number "a" to execute measurement. 0001: indicates the 3-digit measurement execution time (000 indicates instantaneous), and the 4th digit indicates the number of data to be returned (1 piece).
aD0! aD1! aD2! aD3!	a+1000.0<CR>><LF>	Request to send data to the device with address number "a". The output value is always appended with a sign (+ or -). If there is more than one output, the sign is also the delimiter. D0: Irradiance (mW/m ²) 1 digit after decimal point D1: Sensor output voltage (mV) 4 digits after decimal point and Sensor temperature (Celsius) 2 digits after decimal point D2: X-axis tilt angle (degree) 1 digit after decimal point, forward/backward with connector facing back, positive value when back is up, Y-axis tilt angle (degree) 1 digit after decimal point, left/right with connector facing back, negative value when left is down D3: Temperature inside enclosure (°C) 1 digit after the decimal point, Humidity inside the enclosure (%RH) 1 digit after the decimal point. If the pre-measurement command is "MC", then three CRC characters are followed, please refer to SDI-12 standard for the content of CRC characters.
aMC!	a0011<CR><LF>	Request the device with address number "a" to start measurement and request the CRC to confirm that the command is correctly accepted. The response format is the same as "aM!"
aC!	a00101<CR><LF>	This device is the same as the "aM!" command except for the difference in the number of response characters. The character following a indicates the number of seconds (3 digits) and the number of data (2 digits).
aCC!	a00101<CR><LF>	This transmitter is the same as the "aMC!" command except for the difference in the number of response characters.
aR0!	a+0.0<CR><LF>	Request a measurement from the device with address number "a". Measurement is executed and a response is returned immediately. The answer is similar to "aD0!" to "aD2!" command.
aRC0!	a+0.0EmT<CR>R><LF>	Request measurement from the device with address number "a" and request error detection to verify that the command was accepted correctly. Measurement is executed and the measured value with three CRC characters added at the end is returned instantly.
aXSE!	a+XX.XX<CR>><LF>	Read the sensitivity constant of this device. Two digits after the decimal point.
aXCD!	aYYYYMMDD<CR><LF>	Read the calibration date of this device. YYYY: AD, MM: month, DD: day.
METADATA	Variable depending on request data	Identify Measurement Commands and Identify Measurement Parameter Commands are supported.

A-5. About recalibration

When recalibrating at a recalibration center other than EKO, the calibration scale of the other center may differ slightly from the UV radiometer calibration scale and sensitivity constants ($\mu\text{V}/\text{W}\cdot\text{m}^{-2}$) obtained by EKO. The differences may be caused by differences in the calibration method, differences in the reference standard, measurement uncertainty, and measurement conditions.

If a new sensitivity constant was found and needs to be applied to the UV radiometer, it can be applied in two ways:

- 1) (Post data correction) Multiply the relative difference of the irradiance value measured with the UV radiometer. In this case, the original factory sensitivity value given by EKO remains unchanged. When the new sensitivity figure was found apply the ratio of the new and original calibration figure according to the formula below:

$$I_{\text{new}} [\text{W}/\text{m}^2] = \frac{E [\mu\text{V}]}{S_{\text{original}} [\mu\text{V}/\text{W}\cdot\text{m}^{-2}]} \times \frac{S_{\text{original}} [\mu\text{V}/\text{W}\cdot\text{m}^{-2}]}{S_{\text{new}} [\mu\text{V}/\text{W}\cdot\text{m}^{-2}]}$$

Example:

It was proven that there was a relative difference in irradiance measured by MS-10S/11S and the reference UV radiometer. In this example the irradiance measured by MS-10S/11S was lower than the irradiance measured by the reference UV radiometer, a new sensitivity value can be calculated and applied by the following equation.

For MS-10S

$$S_{\text{new}} = I_{\text{sensor}} / I_{\text{ref}} \times S_{\text{original}}$$

S_{new}	New MS-10S Sensitivity ($\mu\text{V}/\text{W}/\text{m}^2$)
S_{original}	MS-10S Original Sensitivity ($\mu\text{V}/\text{W}/\text{m}^2$)
I_{sensor}	Irradiance measured by MS-10S (W/m^2)
I_{ref}	Irradiance measured by reference UV radiometer (W/m^2)

For MS-11S

$$S_{\text{new}} = I_{\text{sensor}} / I_{\text{ref}} \times S_{\text{original}}$$

S_{new}	New MS-11S Sensitivity ($\mu\text{V}/\text{mW}/\text{m}^2$)
S_{original}	MS-11S Original Sensitivity ($\mu\text{V}/\text{mW}/\text{m}^2$)
I_{sensor}	Irradiance measured by MS-11S (mW/m^2)
I_{ref}	Irradiance measured by reference UV radiometer (mW/m^2)

- 2) (Change the sensitivity figure of the MS-10S/11S) Set a new sensitivity figure to the MS-10S/11S. This can be done via through the Hibi software. Connect the MS-10S/11S to a PC with a RS485/USB converter cable. In settings, the new sensitivity figure can be applied. The original sensitivity figure remains, but will be replaced by the "last" sensitivity figure. Multiple calibration figures can be stored inside the UV radiometer, the "last" sensitivity figure is the actual one to calculate the irradiance.

A-6. Setting Report



EKO INSTRUMENTS CO.,LTD.
1-21-8 Hatagaya, Shibuya-ku,
Tokyo 151-0072 Japan
P. +81.3.3469.6713
F. +81.3.3469.6719
www.eko.co.jp

S-series Setting Report

Issue Date: 1-Jul-25

Factory setting data	
Sensor type	UV Radiometer
Model name	MS-10S
Serial number	12345678
Manufacturing date	April 8, 2025
Calibration date	April 8, 2025
Analog sensitivity $[\mu\text{V}/\text{W}/\text{m}^2]$	5678.91
Hardware version	7
Firmware version	7054

Current output range	Current output
Enable/Disable	Enable (Default)
Output range corresponding to 4-20 [mA].	0- 150 [W/m ²]

Current output range	Current output
Enable/Disable	Enable (Default)
Output range corresponding to 0-10 [mA].	0- 150 [W/m ²]

Modbus RTU	Setting
Enable/Disable	Enable (Default)
Address	78
Baudrate	19200
Parity	EVEN
Reg. type	EKO-S

SDI-12	Setting
Enable/Disable ^(*)	Disable (Default)
Address	1
Baudrate	1200

(*) SDI-12 output is only supported by MS-10S/11S with the following product serial numbers.

MS-10S : UVA22001~UVA22023、EX22234.01~EX22392.02

MS-11S : UVB22001~UVB22017、EX22166.17~EX22392.05

A-7. Surge protection

Since a surge protection board is embedded inside the UV radiometer, this alone provides strong protection against lightning surges.

However, if the UV radiometer cable is longer than 10m, or if multiple UV radiometer are connected and the total cable length exceeds 10m, the connected loggers, power supply, and other devices may be damaged by lightning surges.

Please refer to the figure below and add an appropriate SPD to protect the measurement system.

A. Modbus connection (when the cable length exceeds 10m)

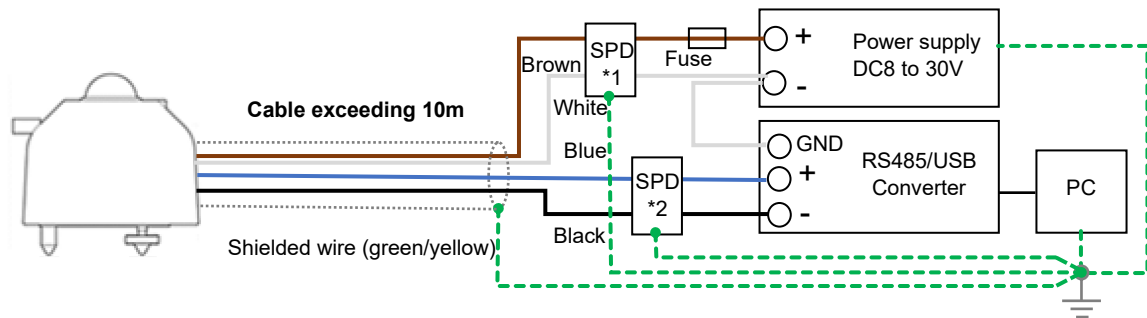

Figure A7-1. Modbus connection (when the cable length exceeds 10m, etc.)

*1 *2

If the cable length exceeds 10m, it is recommended to set up an SPD for the communication line and an SPD for the DC power supply because surges may enter from the communication line and the power supply line.

B. SDI-12^[1] connection (when the cable length exceeds 10m)

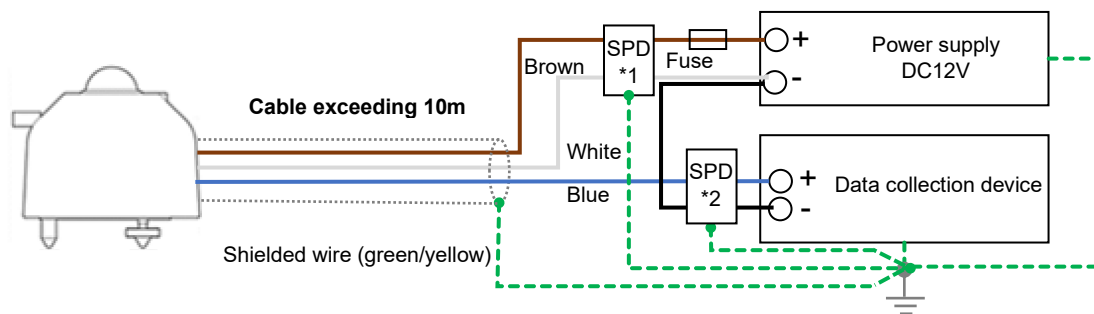

Figure A7-2. SDI-12 connection (when the cable length exceeds 10m, etc.)

*1 *2

If the cable length exceeds 10m, it is recommended to set up an SPD for the communication line and an SPD for the DC power supply because surges may enter from the communication line and the power supply line.

[1] SDI-12 output is only supported by MS-10S/11S with the following product serial numbers.

MS-10S : UVA22001~UVA22023, EX22234.01~EX22392.02

MS-11S : UVB22001~UVB22017, EX22166.17~EX22392.05

In the case of lightning surges, the more countermeasure components are used, the lower the probability of failure. However, the type, rating, and connection method of the SPD to be used vary depending on the manufacturer, so please read the instruction manual of each manufacturer carefully.



EKO Asia, Oceania

1-21-8 Hatagaya,
Shibuya-ku, Tokyo
151-0072 Japan
P. +81.3.3469.6711
F. +81.3.3469.6719
info@eko-instruments.com
www.eko-instruments.com

EKO North America

2570 North First Street,
Suite 200, San Jose,
CA 95131, USA
P. +1-408-977-7751
F. +1-408-977-7741
sales-usa@eko-instruments.com
www.eko-instruments.com

**EKO Europe,
Middle East, Africa,
South America**

Lulofsstraat 55, Unit 28,
2521 AL, The Hague,
The Netherlands
P. +31 [0]70 3050117
sales-eu@eko-instruments.com
www.eko-instruments.com