

It is Good to Know

Thank you for purchasing the RSB-02 Rotating Shadow Band. This Quick Start Guide provides basic instructions to help you set up and get started. Please see the Instruction Manual for more detailed information about this product.

Product Warranty

Your RSB-02 Rotating Shadow Band comes with a 2-year warranty while the MS-80SH comes with a 5-year warranty.
Please note: All of our products are tested to ensure that they meet their published specifications. The warranty included in the conditions of delivery is valid only if the product has been installed and used in accordance with the instructions provided in the Instruction Manual*.



1 In the System

Name/Specification	Qty.	Name/Specification	Qty.
Shadow band	1	Fastening bolt set (M5×30mm) Fastening bolt set (M6×50mm) Washer (M6) Nut (M6)	2 4 8 4
Pyranometer MS-80SH	1	C-BOX unit	1
Cable (Standard 10m, Option 20m, 30m : Shielded cable with connector)* Cable (1.5 m Shielded cable with both straight connector) Cable (1.5 m Shielded cable with straight - angled connector)	1 1 1	Rotating shadow band main unit Alignment jig	1 1
Fixed foot	2	Quick Start Guide	1
USB-KIT (Optional)	(1)	Instruction Manual**	

* When using the optional shielded cable with connector (20m or 30m), be sure to set a power supply voltage to 24 VDC. **Instruction Manual can be downloaded from our website.

First, please check the package contents. If any part is missing or damaged, please contact EKO or your local EKO distributor.

• We recommended that you keep the original packaging for return shipping in case of recalibration or repair.

Required Tools & Devices

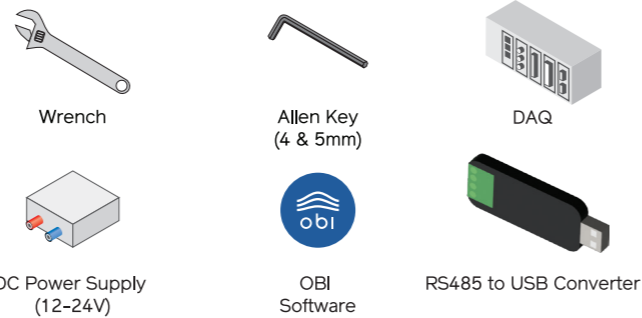

2 Main Unit Assembly

- Cautions About Installation**
- Switch off power during setup, service and maintenance.
 - When installing or carrying the main unit, do not lift it by the shadow band. The band may break.
 - Be aware when approaching, the device suddenly moves.

1 Attach the Shadow Band

- 1 Attach the shadow band to the band holder as shown in the figure below.
- 2 Tighten the two bolts with a hex wrench (4 mm).

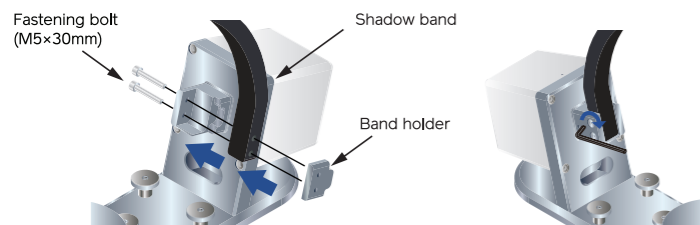

- Fully tighten the two bolts. (Specified torque: 3 Nm)
- After tightening, confirm that the band does not rattle.

2 Attach the Pyranometer

- 1 ① Remove the pyranometer leveling feet (2 pcs).
② Attach the included fixed feet (2 pcs).

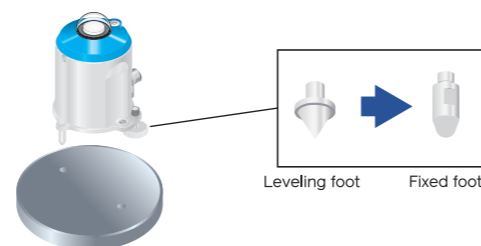

2 Main Unit Assembly / Continuation

- 2 ① Place the pyranometer on the rotating shadow band main unit, and align to the mounting holes.
② Put the washers (M5) onto the included cap bolts (M5×30mm) and insert these into the pyranometer mounting holes.
③ Tighten the cap bolts with a hex wrench. (4 mm, Specified torque: 2.0 Nm)
- 3 ① Orient so that the spirit level on the pyranometer can be seen through the cutout in the sun screen.
② Place the sun screen on so that the two protrusions on the inside of the sun screen slip into the notches on the pyranometer.
③ Hand tighten the sun screen mounting screw (knurled screw).
④ Make sure that the sun screen does not come off.

⚠ Install the pyranometer cable connector so that it faces the outside of the rotating shadow band main unit.

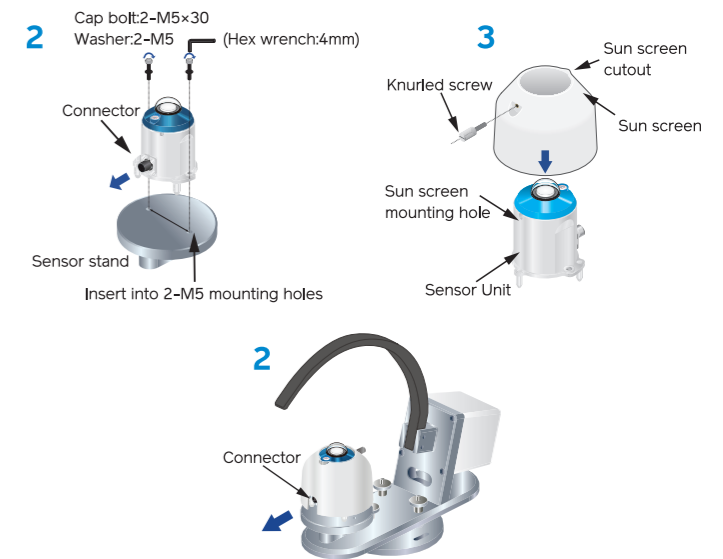

3 Wiring

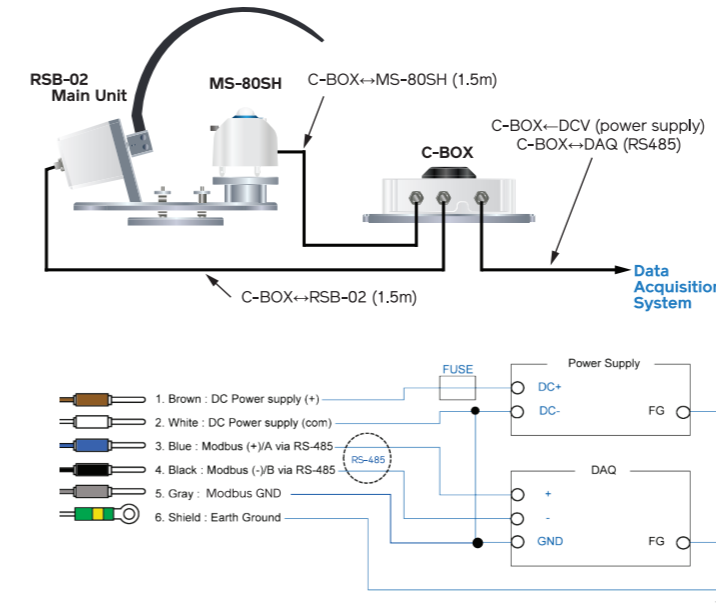

Connect wires **No. 1** and **No. 2** to the terminals of the power supply (12 to 24V DC). Make sure to connect a fuse (2.5A slow blow fuse) in series to wire **No.1**. Connect wire **No. 3** and **No. 4** to the DAQ system. Ground the system with the shield (**No. 6**), power supply and DAQ (**FG**).

Default Communication Settings

Modbus RTU:
19200bps / 8bit / Even / 1 stop bit / node 1

Configuring the first pyranometer

Use the included Obi application software, or follow the steps below to configure.

- 1 Set register 69 GHLNODE_ADDR to the pyranometer address*.
- 2 Set register 64 UPDATE to 1.
- 3 Turn the system off and then on again.

*Last two digits of the pyranometer serial number.

4 Startup Checks

Shadow Band:

Once wiring is complete and the power is supplied to the C-BOX, check that the RSB-02 shadow band starts automatically and it is positioned vertically at 90° matching the squares for a few seconds before automatically returning to the resting position.



- After position information has been acquired from GPS satellites (at least 5 GPS on sight) the equipment is ready to begin measurements.
- You can check the data acquired from the satellite after Obi is connected or by checking the MODBUS register 27.

5 On-Site Installation

1 Checking Installation Location

- Free from shadows cast by structures like steel towers and buildings.
- There are no brightly colored walls or signboards nearby that could easily reflect sunlight.
- Conducive to daily maintenance (cleaning the glass dome, etc.).
- A visibility angle of 180° with nothing to obstruct sunlight over the entire area (at minimum, this should be a place with a solar altitude angle of 5° or more, and no cover).

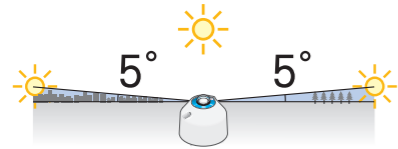

- During installation, please ensure there are no obstructions to the RSB-02's shadow band rotation, such as existing equipment or the C-BOX.

2 Determining Installation Orientation

- Prepare a setup base with fixing holes for the RSB base plate.
- Make sure the motor is facing the equator.

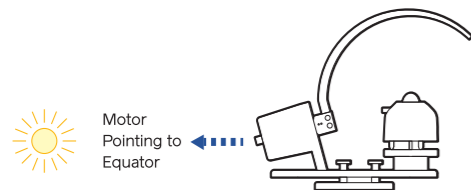

- Perform the installation on a clear, sunny day if possible. In absence of direct sunlight, you can use a compass but be aware of magnetic declination.

Check the manual for further instruction.

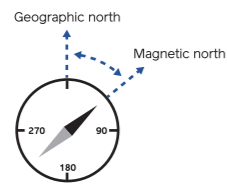

- Use the OBI application to perform the INSTALLATION MODE or follow the steps below to set the band in TSB (tracking shadow band).

- Set register 74 WORK_MODE to 2 and register 64 UPDATE to 1.

- Turn the system off and then on again.

- After the set-up is complete, if you want to operate the unit in RSB mode set register 74 WORK_MODE to 1 and set register 64 UPDATE to 1.

Check the manual for further instruction.

3 Leveling

Level the instrument, make sure the bubble is centred in the red circle.

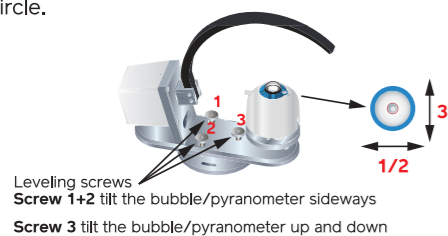

- Deviation from a horizontal position may lead to error between the orientation and angle of incidence.
- Regularly check that the equipment is level.

4 Adjusting Installation Orientation

While in TSB mode, attach the alignment jig into the band. Ensure the band's shadow is aligned within the jig's guidelines.

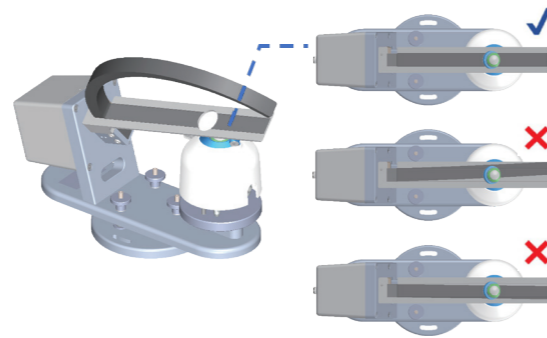

- To return to RSB mode after completing adjustments, set register 74 WORK_Mode to 1, and then set register 64 UPDATE to 1.

5 Securing the RSB-02 main unit

Securing the RSB-02 main unit to the installation location with the two bolts. (Specified torque: 5.2 Nm) After installation, remove the alignment jig. Check the level and make fine leveling if necessary to ensure it is horizontal.

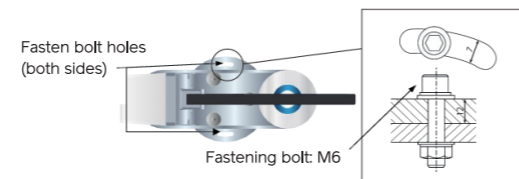

6 Securing the C-BOX

Place the C-BOX as close as possible to the rotating shadow band main unit. However, please maintain a distance that does not affect the operation of the shadow band. Secure the C-BOX to the installation base with two bolts, washers and nuts (M6). Ensure the GPS unit is facing the sky. It can be installed horizontally or vertically.

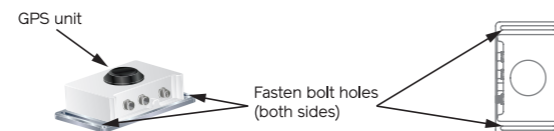

6 Dimensions

Rotating shadow band Main unit

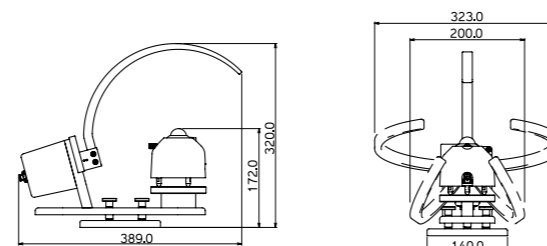

C-BOX

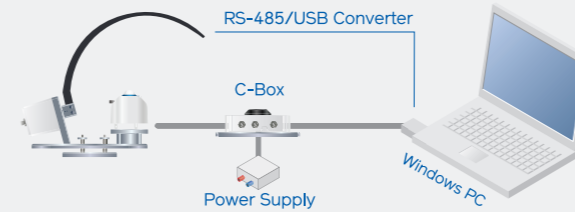
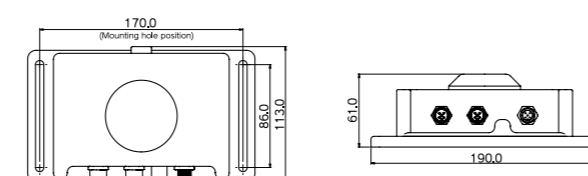

What can Obi do?

Change your communication settings

Manage the communication settings between sensors and C-Box and output communication.

Realtime display of measurement values and sensor conditions

Get instant, easy to read measurement values and live information on the condition of your system (temperature, humidity, tilt, GPS status, timestamp, solar position).

Dashboard



Record measurement data

Measurement data can be recorded and output as a CSV (comma delimited) file.

Change measurement mode

Modify RSB-02 measurement mode RSB or TSB, default is TSB.

1 Preparation

1 Download & Install

Download Obi from the MS-80SH Plus+ product page on the EKO website. Execute the installer file (.exe) and install Obi on your PC. If a dialogue window appears during the installation process, click 'Run Anyway'.

2 Connect sensor and PC using cable

Connect 5 cable terminals as shown in the Communication Cable Wiring Diagram.

Communication Cable Wiring Diagram

How to connect to PC when using general purpose RS-485/USB converter.

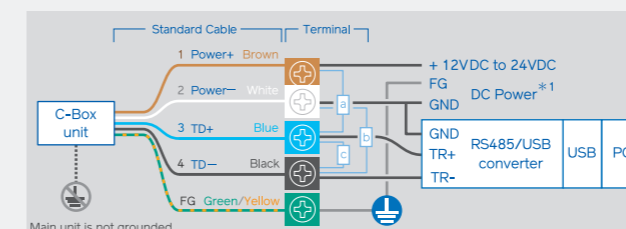

a : Pull-up resistor 680Ω b : Pull-down resistor 680Ω c : Terminating resistor 120Ω

Depending on the converter cable type and specifications, pull-up/pull-down resistors and a termination resistor are required. With the optional EKO Converter cable, additional resistors are not necessary.

* External power supply between 12VDC to 24VDC is required. The 5 VDC supply from USB will not be sufficient to power the system.

3 Start up Obi

To automatically connect, remove the cable from the C-Box, click CONNECT, then reconnect the cable within 10 seconds.

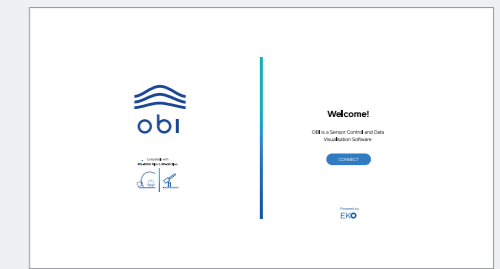

If the auto-connect doesn't establish a connection, please refer to the MS-80SH Plus+ manual for further information on troubleshooting.

2 Operation

- Once the connection between Obi and the sensor is established, the Obi dashboard will automatically load.

2 Communication Settings

Once the connection to the C-Box is established, make sure that you configure the pyranometer address in "Node Address" (a); By default the address is the last two digits of the pyranometer serial number (e.g., if the serial number ends in 100, enter 00).

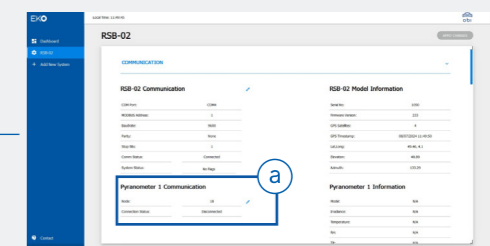

3 Measurement Modes

- RSB Mode:** Intermittently shades and un-shade the pyranometer. A single pyranometer measures GHI and DHI, and calculates DNI. The measured value is updated every 15 seconds.
- TSB Mode:** This working mode continuously shades the pyranometer by tracking the movement of the sun. It measures DHI continuously.
- Manual Mode:** This mode allows the band angle to be set by the user.

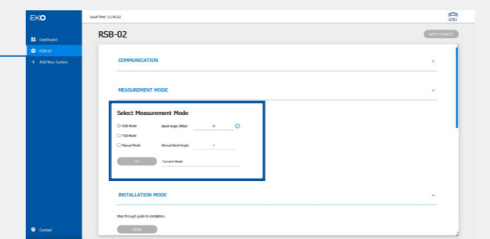

For further information, please check the manual.



EKO Japan, Asia P.+81 (3) 3469 6711
EKO North America P.+1 408 977 7751
EKO Europe, Middle East, Africa, South America P.+31 (0) 70 305 0117