

INSTRUCTION MANUAL

Pyrheliometer
ISO9060: 2018 Class A
ISO9060: 1990 First class

MS-57SH

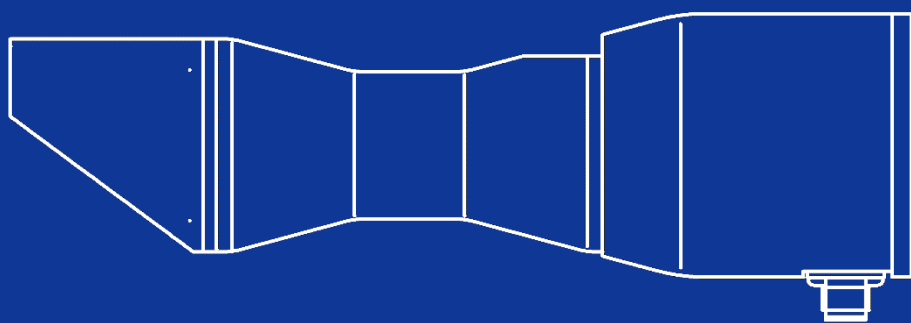

1. Index

1.	Index	1
2.	Important User Information	2
2-1.	Contact Information	2
2-2.	Warranty and Liability	2
2-3.	About Operating Manual	3
2-4.	Environment	3
2-5.	ISO/IEC 17025	4
2-6.	CE Declaration	5
3.	Safety Information	6
3-1.	WARNING/CAUTION	6
4.	Introduction	8
4-1.	Introduction	8
4-2.	Package Contents	9
5.	Getting Started	10
5-1.	Parts Name and Descriptions	10
5-2.	Setup	11
5-3.	Wiring	13
5-4.	Connections	14
5-5.	Measurements	20
6.	Maintenance & Troubleshooting	23
6-1.	Maintenance	23
6-2.	Calibration and Measurement Uncertainty	25
6-3.	Troubleshooting	26
7.	Specification	27
7-1.	Specifications	27
7-2.	Dimensions	30
7-3.	Output Cables	31
7-4.	Accessories List	32
APPENDIX		33
A-1.	Radiometric Terms	33
A-2.	Pyrheliometer Characteristics	34
A-3.	Software (Hibi)	35
A-4.	Communication Specifications (Modbus RTU)	49
A-5.	Communication specification (SDI-12)	57
A-6.	About recalibration	60
A-7.	Temperature Response Measurement Test Report	61
A-8.	MS-57SH Setting Report	63
A-9.	Surge protection	64

2. Important User Information

Thank you for using EKO Products

Make sure to read this instruction manual thoroughly and to understand the contents before starting to operate the instrument. Keep this manual in safe and handy place for whenever it is needed.

For any questions, please contact us at below:

2-1. Contact Information

EKO INSTRUMENTS CO., LTD.

Asia, Oceania Region

www.eko-instruments.com	EKO INSTRUMENTS Co., Ltd.	Tel: +81 (3) 3469-6713
info@eko-instruments.com	1-21-8 Hatagaya, Shibuya-ku	Fax: +81 (3) 3469-6719
	Tokyo, 151-0072 Japan	

Europe, Middle East, Africa, South America Region

www.eko-instruments.com	EKO INSTRUMENTS Europe B.V.	Tel: +31 (0)70 3050117
sales-eu@eko-instruments.com	Lulofsstraat 55, Unit 28,	
	2521 AL, Den Haag, The Netherlands	

North America Region

www.eko-instruments.com	EKO INSTRUMENTS USA Inc.	Tel: +1 408-977-7751
sales-usa@eko-instruments.com	111 North Market Street, Suite 300	Fax: +1 408-977-7741
	San Jose, CA 95113 USA	

2-2. Warranty and Liability

For warranty terms and conditions, please contact EKO Instruments or your distributor for further details.

EKO guarantees that all products have been tested to ensure the instrument meets its published specifications.

The product warranty is valid only if the product has been installed and used according to the instructions provided in this operating manual.

In case any manufacturing defect[s] will occur, the defective part[s] will be repaired or replaced under warranty; however, the warranty will not be applicable if:

- Any modification or repair has been done by anyone other than EKO service personnel.
- The damage or defect is caused by disrespecting the specifications published on the Product Sheet or Manual.
- There is discoloration of the pyrgeometer body, sun shield, and cable within a range that does not affect the function and performance of the product.

2-3. About Operating Manual

Copy Rights Reserved by EKO INSTRUMENTS CO., LTD. Making copies of whole or part of this document without permission from EKO is prohibited.

This manual was issued: Jul. 30, 2024

Version Number: 1

2-4. Environment

1. WEEE Directive (Waste Electrical and Electronic Equipment)



Although this product is not subject to the WEEE Directive 2002/96/EC, please make sure that it should not be disposed of in a landfill or with municipal or household waste. For proper processing, collection and recycling, please contact a specialist collection site or facility.

Disposing of this product correctly will help save valuable resources and prevent any potential negative effects on human health and the environment, which could otherwise arise from inappropriate waste handling.

2. RoHS Directive

EKO Instruments has completed a comprehensive evaluation of its product range to ensure compliance with RoHS Directive 2011/65/EU+(EU)2015/863 regarding maximum concentration values for substances.

As a result, all products are manufactured using raw materials which concentration level are less than the hazardous substances specified in RoHS Directive 2011/65/EU+ (EU) 2015/863.

2-5. ISO/IEC 17025

EKO Instruments Co. Ltd. calibration laboratory is accredited by Perry Johnson Laboratory Accreditation, Inc. (PJLA) to perform pyranometer and pyrhemliometer calibrations in accordance with the requirements of ISO/IEC17025, which are relevant to calibration and testing.

EKO is a unique manufacturer who can offer calibration service for pyranometers and pyrhemliometers in-house. Based on the applied calibration methods EKO provides the best quality solar sensor calibrations compliant to the international standards defined by ISO/IEC17025 / 9847 (Indoor calibration method) and ISO9059 (Outdoor calibration method).

ISO/IEC17025 provides a globally accepted basis for laboratory accreditation that specifies the management and technical requirements. With calibrations performed at the EKO Instruments laboratory we enable our customers to:

- Clearly identify the applied calibration methods and precision
- Be traceable to the World Radiation Reference (WRR) through defined industrial standards:
 - ISO9846 Calibration of a pyranometer using a pyrhemliometer
 - ISO9847 Calibration of field pyranometer by comparison to a reference pyranometer
 - ISO9059 Calibration of field pyrhemliometers by comparison to a reference pyrhemliometer
- Obtain repeatable and reliable calibration test results through consistent operations

Our clients will obtain a highly reliable data by using an ISO/IEC17025 calibrated sensor. Our Accredited lab is regularly re-examined to ensure that they maintain their standards of technical expertise.

2-6. CE Declaration



IMPORTANT USER INFORMATION



DECLARATION OF CONFORMITY

We: EKO INSTRUMENTS CO., LTD
1-21-8 Hatagaya Shibuya-ku, Tokyo
151-0072 JAPAN

Declare under our sole responsibility that the product:

Product Name: pyrhelimeter
Model No.: MS-57SH

_To which this declaration relates is in conformity with the following
harmonized standards of other normative documents:

Harmonized standards:

EN 61326-1:2013 (Emission)
CISPR11 Class A
EN 61326-1:2013 (Immunity)
EN 61000-4-2 EN 61000-4-3
EN 61000-4-4 EN 61000-4-5
EN 61000-4-6

Following the provisions of the directive:

EMC-directive : 2014/30/EU

Date: April. 11, 2023
Position of Authorized Signatory: General Manager of Quality Assurance Div.
Name of Authorized Signatory: Taiji Yamashita

Signature of Authorized Signatory: 

3. Safety Information

EKO products are designed and manufactured under the consideration of the safety precautions. Please make sure to read and understand this instruction manual thoroughly in order to be able to operate the instrument safely and in the correct manner.



WARNING CAUTION

Attention to user; pay attention to the instructions given on the instruction manual with this sign.



HIGH VOLTAGE WARNING

High voltage is used; pay special attention to instructions given in this instruction manual with this sign to prevent electric leakage and/or electric shocks.



3-1. WARNING/CAUTION

1. Setup

- When installing the pyrheliometer on the tracker, fix it firmly. Otherwise, it may fall due to strong winds or earthquakes, leading to an unexpected accident.
- Make sure the instrument and the cables are installed in a location where they will not get soaked.
- Insert the output cable into the connector port and tighten it all the way. Push the connector in, and check to make sure the screw is tight. If the connection is loose, water can enter the unit and cause it to malfunction.
- When using this instrument by connecting to a measuring instrument, make sure to connect the shield cable to either the signal ground terminal on the measuring instrument side or GND (the reference potential on the single end input side). Otherwise noise may occur in the measurement data. In addition, the surge protection circuit inside the pyrheliometer will not operate properly if the shield wire is not connected to ground earth.
- Although this product is tested to meet EMC Directive compliance requirements, it may not fully satisfy its primary specification/performance when using this product near following locations where strong electromagnetic wave is generated. Please pay attention to the installation environment.
 - Outdoor: High voltage power line, power receiver/distribution facility, etc.
 - Indoor: Large-size chiller, large rotation device, microwave, etc.
- Do not use this product in environment where corrosive gas, such as ammonia and sulfurous acid gas, are generated. It may cause malfunction.
- Do not install in an area likely to result in salt damage. It may cause malfunction by paint peeling or corrosion. When installing in an area at risk of salt damage, make sure to take the following measures:
 1. Wrap the connector with self-fusing tape
 2. Change the fixing screw to a bolt screw made of aluminum
 3. Run the cables in a plastic or metal pipe treated with salt-resistant paint such as molten zinc plating
 4. Periodically clean.
- Do not use this instrument in vacuum environment.

- If the cable and main unit are in risk for getting damaged by birds and small animals, protect the cable and the main unit by using:
 1. Reflective tape
 2. Repellent
 3. Cable duct
 4. Installing bird-spike

2. Handling

- Be careful with glass window when handling instruments. Strong impact to this part may damage the glass and may cause injuries by broken glass parts.

3. Signal Cable

- Make sure to ground the signal cable. When grounding is insufficient, it may cause not only measurement error due to noise, but also cause electric shock and leakage accidents.
- Check the voltage and types of specified power supply before connecting this instrument. When improper power supply is connected, it may cause malfunction and/or accident.
- Use this instrument with a 0.5A fuse connected to the power supply line in series. Without connecting the fuse the large-current flowing through the power supply may generate heat, potentially leading to internal damage of the electronics and fire.

4. About RS485 Modbus RTU connection

- This product supports communication through the RS485 Modbus RTU.
- It is recommended to use the optional EKO converter cable when connecting MS-57SH to a PC.
- Depending on the USB-RS485 converter type, an additional termination resistor (120Ω) and/or pull-up/pull-down resistor (680Ω) is required for proper communication.
- When connecting to a RS485 (Modbus RTU) master peripheral device, an additional termination resistor (120Ω) and/or pull-up/pull-down resistor (680Ω) is required for proper communication.

4. Introduction

4-1. Introduction

The ISO9060:2018 “Fast response and spectrally flat Class A” pyrheliometer MS-57SH is a research grade normal incidence direct solar irradiance sensor also known as a pyrheliometer or DNI sensor, which is highly suitable for routine operation on automated Sun Tracker. The all-weather MS-57SH is sensitive to solar irradiance throughout the spectral range 200 to 4000nm and can work under most extreme conditions in a temperature range from -40°C to 80°C.

In principle to perform high precision direct solar radiation measurements under non-stable atmospheric conditions, ideally a fast-responding detector is required to detect quick radiation changes. Although photodiode type detector offers a quick response but it has a limited spectral sensitive range; in contrary thermopile broadband detectors cover the full spectral range, but it is considered to be slow. The versatile MS-57SH combines all those features of a quick broadband detector enabled by an advanced technology thermopile detector. It combines a unique fast response time (<0.5s 99%), high sensitivity, excellent thermal stability and very low temperature coefficient to make it hardly immune to ambient temperature variations, therefore it is suitable to be used in a wide temperature range.

The MS-57SH has a standard full 5° (degrees) opening angle and 1° slope angle as defined by ISO Pyrheliometers Standards and greatly performs when used in combination with the EKO STR-21(G), STR-22(G) or STR-32(G) Sun Tracker. The standard built-in platinum resistance temperature sensor (Pt100, Class A, IEC751 compliance) can be used as a temperature reference for extensive research purposes. MS-57SH has the window heating function that mitigates dew or frost build-up on the quartz window.

The MS-57SH has a robust but compact and smooth design which forms the new generation of EKO Instruments solar radiometers that are designed for most demanding Photovoltaic and Meteorological applications at any place on earth. The MS-57SH also no longer has a drying cartridge, with silica gel instead used inside to keep the sensor dry.

Each MS-57SH is calibrated and tested at EKO upon manufacture against EKO's reference sensors which are fully traceable to the WRR (World Radiometric Reference) maintained at the PMOD/WRC (Physikalisch-Meteorologisches Observatorium Davos/World Radiation Center) in Davos, Switzerland. Besides, EKO provides a unique calibration service for pyranometers and pyrheliometers compliant to the international standards defined by ISO/IEC17025 / 9059 (Outdoor calibration method). When an ISO/ IEC17025 calibrated sensor is purchased, EKO offers sensor at nearly constant calibration uncertainty. The Accredited lab is regularly re-examined to ensure that they maintain their standards of technical expertise.

MS-57SH unique properties:

Dew and frost mitigation The window heating function reduces dew and frost build-up on the window. The window heating function can be switched ON/OFF as needed, and when ON, the temperature of the quartz window is 1°C to 3°C higher than the ambient temperature.

MS-57SH features smart sensor technology and onboard diagnostic functions. 2 different output types can be selected, which is a great benefit for system integrators who work with various industrial standards. This new Smart transducer includes internal temperature and humidity sensors and a tilt sensor for remote sensor diagnostics. These internal sensors will help the user to monitor the stability of the irradiance sensors as well as to ensure proper installation and maintenance practices.

Up to 31 smart sensors per one Master can be connected in one network. The signal converter settings can be changed using the optional RS485 / USB converter cable and the configurator software.

4-2. Package Contents

Check the package contents first; if any missing item or damage is noticed, please contact EKO immediately.

Table 4-1. Package Contents

Contents	MS-57SH
Pyrheliometer	○
Output Cable	○ ⁽¹⁾
Instruction Manual	Not included in the package [Please download from EKO Website]
Setting Report	○ ⁽²⁾
Calibration Certificate	○
Temperature Dependency Report	○
Fixing Ring (Optional)	○

(1) The MS-57SH, standard length is 10m for both signal/power cable. For different length of cables [e.g., to meet your application needs] please contact EKO or your local distributor.

(2) Details about the setting report, see appendix A-8.

5. Getting Started

5-1. Parts Name and Descriptions

Each part name and its main function are described below.

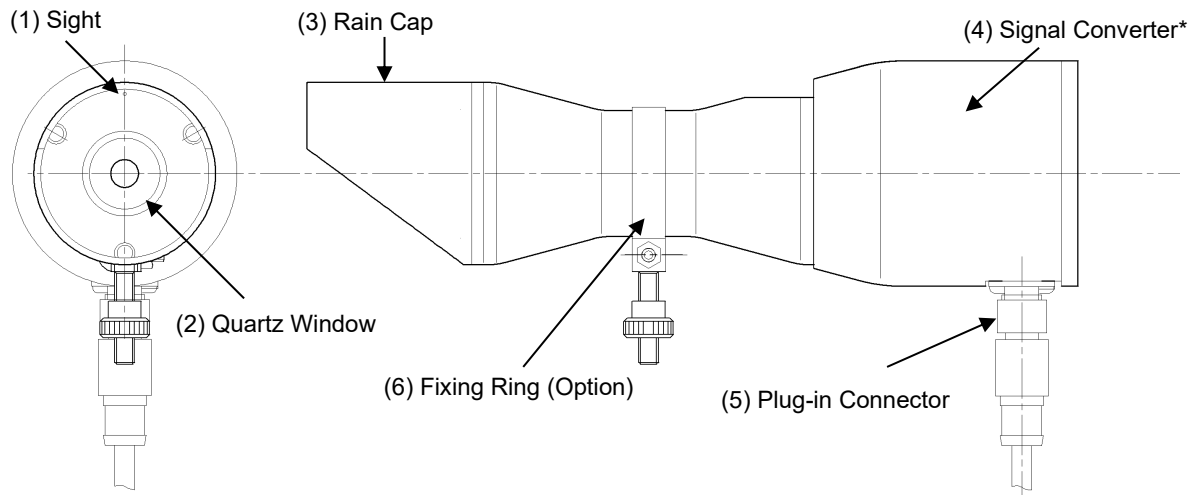

*Signal converter is built-in for MS-57SH.

Figure 5-1. Pyrheliometer Parts Name [MS-57SH]

MS-57SH pyrheliometer is designed to capture direct solar radiation with high precision and long-term reliability. The new concept is a result of combining new technologies with proven pyrheliometer basics to fulfill most stringent demands for solar energy research in the Photovoltaic and Meteorological market.

The Pyrheliometer is based on a well-balanced light weight thermopile detector, which gives a highly stable output under most critical situations and variable measurement conditions. Each detector is individually characterized and temperature compensated to guarantee its best performance. During field operating, the detector temperature can be monitored with a platinum resistance temperature sensor (Class A Pt100) to extend further research applications.

The MS-57SH has a full 5° opening angle and 1° slope angle geometry. The front aperture has a unique integrated alignment sight for easy and precise alignment of the instrument on a Sun Tracker. The rain cap works as a rain shield. In order to attain the proper spectral characteristics and spectral range, the pyrheliometer has Quartz precision optics and ultra-low reflective black detector absorber to capture direct solar radiation in the specified spectral range.

The built-in large-capacity desiccant ensures a dry environment inside the pyrheliometer to protect delicate optical parts from any condensation. A cable with plug in connector is provided for easy handling and flexibility during installation, maintenance and service. The basic construction outline is shown in the assembly drawing.

5-2. Setup

1. Installation

In this application the MS-57SH is mounted on the EKO Sun Tracker STR-21G/22G/32G, which is a fully automatic sun tracking system supporting solar sensors capable of measuring Direct, Diffuse and Global radiation.

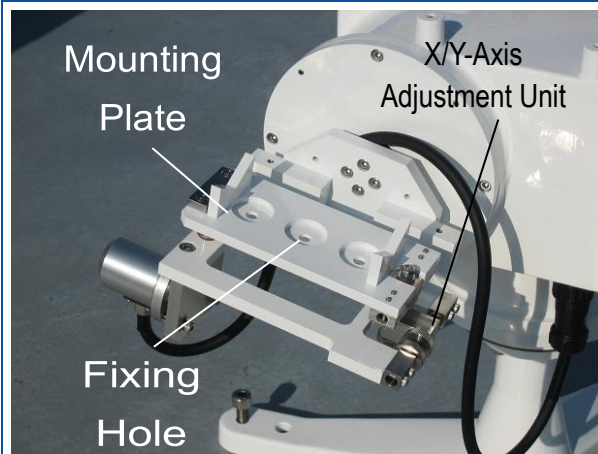

- 1) When mounting the MS-57SH, use the fixing hole in the middle of the mounting plate.

*If the mounting plate is the 2-hole version, it is necessary to replace with 3-hole version.



- 2) Remove the knurling nut from the MS-57SH mounting screw by hand. (Above picture shows condition the knurling nut is removed.)



- 3) Place the MS-57SH on the Sun Tracker mounting plate. Insert the mounting screw through the mounting plate center hole.



- 4) Attach the knurling nut which was removed earlier back on the mounting screw; tighten so the MS-57SH is fixed securely.

When installing on the Sun Tracker, make sure to have enough cable length for Sun Tracker rotational movement.

2. Sight Spot Adjustment

In order to take an accurate measurement, MS-57SH has to be aligned with the sun properly. When the sky is clear, the sunlight will go through the sight and a spot of light is shown on the sight spot surface of body top. Adjust the X/Y-Axis adjustment unit (Zenith and Azimuth angles) so the center of this light spot will hit the dot engraved on the sight spot surface.

When the MS-57SH is installed on an automated sun tracking system, like the EKO Sun Tracker and taking a long-term measurement, check the sight spot on the next day after installation to make sure the spot is still in the place, and continue checking the sight spot periodically.

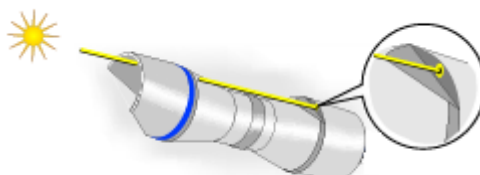

Figure 5-2 Sight Spot Adjustment

3. Setting of window heating function

The initial setting of the window heating function is ON.

To obtain a high condensation/frost reduction effect, always use it in the ON state.

It takes about 3 hours for the window temperature to stabilise after switching ON the window heating function.

For power-saving use, please set it to OFF.

The window heating function can be switched ON/OFF by the following methods.

[Hibi]

The window heating function can be switched ON/OFF using the radio button in the 'Settings' => 'HEATING' screen.

[Modbus RTU]

ON/OFF can be switched by directly rewriting the internal register of the MS-57SH from the control device using RS485 communication.

Register number: 151 ⇒ Set value: OFF = 0, ON = 1

[SDI-12]

ON/OFF can be switched by sending the following commands from the control device to the MS-57SH using SDI-12 communication.

Transmission command: OFF = 'aXHT0!', ON = 'aXHT1!'

5-3. Wiring

To extend the cable lifetime, make sure that the cables are not exposed to direct sun light or rain/wind by lining the cable through a cable conduit. Cable vibrations will potentially cause noise in the output signal. Fasten the cable so that the cable does not swing or move in the wind. Exposure of the signal cable to excessive electromagnetic emissions can cause noise in the output signal as well. Therefore, the cable should be lined at a safe distance from a potential source generating EMC noise, such as an AC power supply, high voltage lines or telecom antenna.

1. Ground connection



<MS-57SH>

The pyrheliometer housing is connected to the shield wire of the cable, so the shield wire shall be connected to the ground on the measuring instrument side. The surge protection circuit inside the pyrheliometer will not operate properly if the shield wire is not connected to ground. Also do not connect the pyrheliometer housing to ground. It will be a two-point ground and it causes a noise.

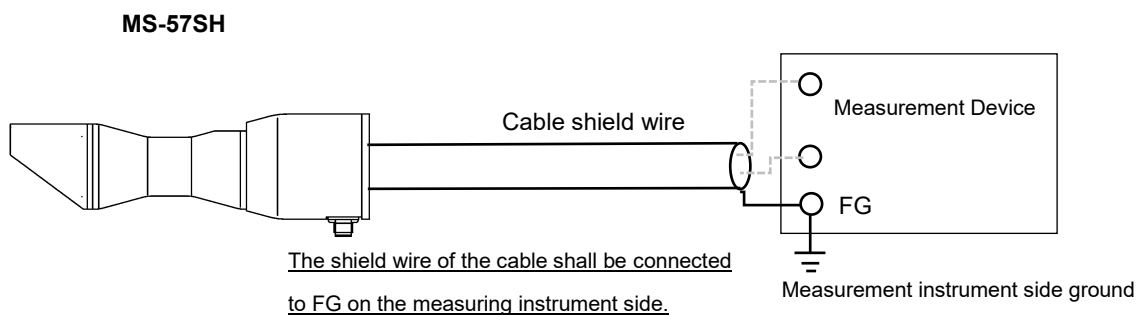

Figure 5-3. MS-57SH ground connection method

2. Wiring procedure

Connect the output cable to the MS-57SH: **Insert the output cable into the connector port on the back of the sensor unit, and twist clockwise to fasten it. Make sure to tighten the connector all the way.**



- 1) **If the connection is loose, water can enter the unit and cause it to malfunction.**
- 2) Secure the length of the cable to avoid it from being pulled loose.
- 3) Connect the power cable grounding wire to prevent electrical shocks.

5-4. Connections

The MS-57SH features a digital smart processing interface providing advanced measurement functions with 2 different industrial signal outputs (**Modbus RTU, SDI-12**).

Table 5-1. Pyrheliometer output parameters

Output parameters	MS-57SH Modbus RTU / SDI-12
Irradiance	<input type="checkbox"/>
Temperature	<input type="checkbox"/>
Zenith angle	<input type="checkbox"/>
Alerts for abnormal internal humidity of the pyrheliometer	<input type="checkbox"/>
Relative humidity	<input type="checkbox"/>
Alerts for abnormal window heating of the pyrheliometer	<input type="checkbox"/>
Sensor information	<input type="checkbox"/>

1. Digital output (Modbus RTU / SDI-12)

The MS-57SH can work in two digital output modes, respectively Modbus RTU and SDI-12.

PC connection (Modbus RTU)



EKO can provide an optional and approved USB converter for connection with a PC. The converter cable is needed for setup, sensor diagnostics and data logging through the Hibi software. Depending on your region, the optional converter can be different.

- To protect your equipment from noise and surges, the shield wire of the cable shall be connected to ground at a single point. If it is not connected, the electronic equipment may be damaged.
- The shield wire of the cable is connected to the surge protection circuit inside the pyrhelimeter itself and to the enclosure.
- Be sure to connect a fuse, as this may lead to a fire.

For any converter with screw terminals or open wires, connect the 4 wires of the sensor cable with the corresponding wire colour to the RS485 to USB converter (figure 5-5). Some converter cables provide a 5V supply voltage from the USB port, in such case no additional power supply is required. If the window heating function is 'OFF' when the internal settings of the pyrhelimeter are being changed. In any other case use an additional power supply. Connect the power terminals to a DC power supply [8 to 30 V]. We recommend to use a fuse [0.5A] to the DC power supply line [+].

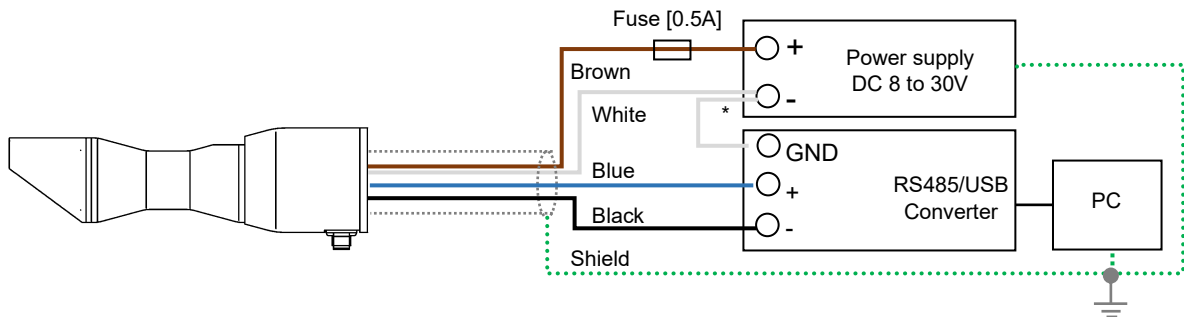

* For stable communication, please connect the minus of the power supply and the GND of RS485/USB converter.

Figure 5-5. How to connect MS-57SH (Modbus RTU)



Depending on the converter type and design properties, some commercial RS485 to USB converters may not work properly. A termination resistor is required to prevent reflections from the end of the transmission line. Pull-up and pull-down resistors are necessary to keep the voltage level constant when the transmission line is in a high impedance state.

Data logger connection (Modbus RTU)

Connect the 4 wires of the sensor cable with the corresponding wire colour to the RS485 communication port of the data logger master and power supply unit (figure 5-5). Connect the power terminals to a DC power supply [8 to 30 V]. We recommend to use a fuse [0.5A] to the DC power supply line [+] for over current protection.

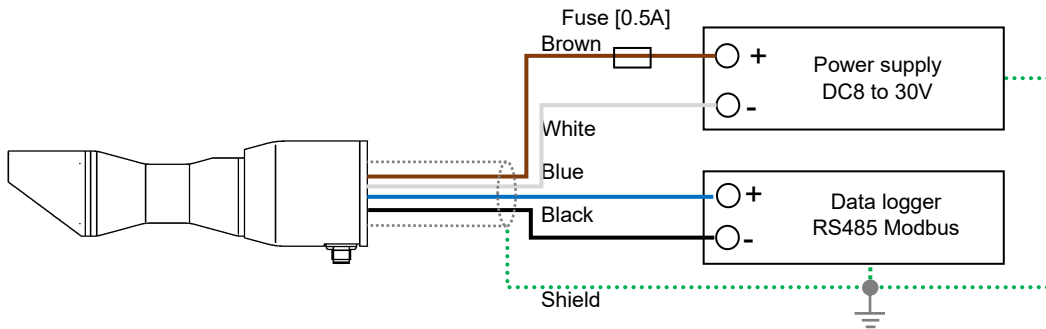

Figure 5-5. How to connect MS-57SH (Modbus RTU RS485)

The MS-57SH can be configured within a multi sensor RS485 Modbus RTU communication network. Up to 31 sensors per one Master can be connected and be assigned with a unique address. For a multiple sensor network the sensors need to be configured according to the recommended RS485 configuration standards as shown in figure 5-6.

The master represents the data-logging device and slaves represent devices such as the MS-57SH or other serial devices in the same network. Connect the communication wires of the slave to the Modbus RTU communication input of the master. Connect a 120Ω termination resistor at the end of the communication line. The master device may have an integrated termination resistor and pull-up and pull-down resistors. If any communication issues occur, apply those separately.

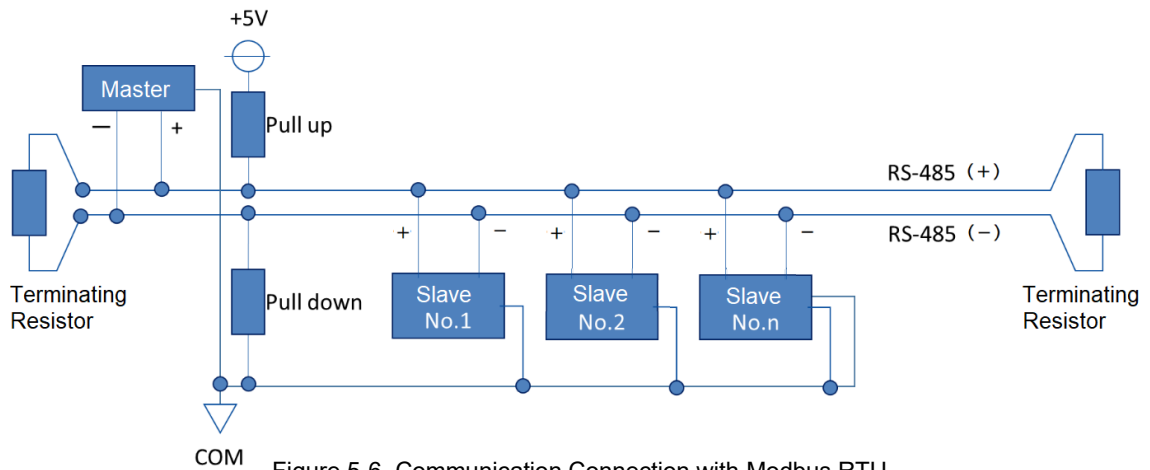

Figure 5-6. Communication Connection with Modbus RTU



Apply a termination resistor (typically 120 to 150Ω) : Typically, reflections occur on long lines, resulting in a receiver misreading logic levels. Proper termination prevents reflections, improving data integrity.

Apply pull-up and pull-down resistors (typically 680 to 850Ω): Necessary to keep the voltage level constant when the transmission line is in a high impedance state.



Communication errors may occur depending on the connection distance and the number of connections. In that case, please prepare and apply a RS485 booster or a repeater.



Although a surge protection board is embedded inside the pyrhelimeter, if the cable length exceeds 10 m, add an appropriate SPD or the like shall be added to protect the measurement system from lightning surges (see A-9).

Data logger connection (SDI-12)

Connect the 3 wires of the sensor cable with the corresponding wire colour to the SDI-12 communication port of the data logger master and power supply unit (figure 5-7). Connect the power terminals to a DC power supply [12 V]. We recommend to use a fuse [0.5A] to the DC power supply line [+] for over current protection.



Interconnect the power supply (-) and SDI-12 (-) line.



➤ **Although a surge protection board is embedded inside the pyrhelimeter, if the cable length exceeds 10 m, add an appropriate SPD or the like to shall be added to protect the measurement system from lightning surges (see A-9).**

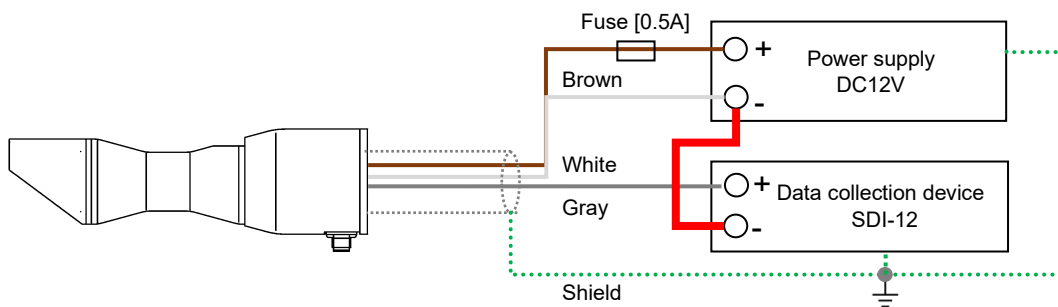

Figure 5-7. How to connect MS-57SH (SDI-12)

The MS-57SH can be configured within a multi sensor SDI-12 communication network. Up to 20 units of S-series sensors can be connected and be assigned with a unique address (*). For a multiple sensor network, the sensors need to be configured according to the recommended SDI-12 configuration standards as shown in figure 5-8. Make sure the cable length between the connecting slave and master be less than 60m.

The shield cable shall be connected to the ground, otherwise noises may occur.

(*) When connecting other SDI-12 communication devices, the upper limit may change.

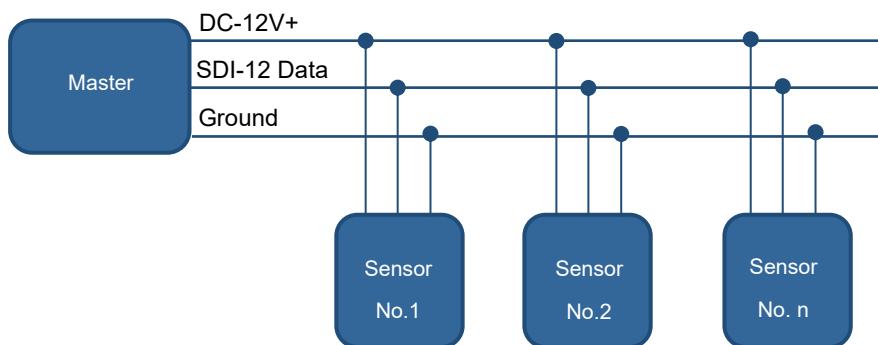

Figure 5-8. Communication Connection with SDI-12

2. Overview wire assignments

Table 5-2. Cable Colour Codes

No.	Wire Color	Modbus RTU	SDI-12
1.	Brown (+)	5VDC (+) ^(*) or 8 to 30VDC (+)	12VDC (+)
2.	White (-)	Vcc GND / RS485 GND	Vcc GND
3.	Blue (+)	RS485 (+)	---
4.	Black (-)	RS485 (-)	---
5.	Gray (+)	---	SDI-12 Data (+)
Shield	Shield	FG ^(**)	FG ^(**)

(*) Window heating function is not available when operating with 5 VDC power supply.

(**)The shield must be connected for surge protection.

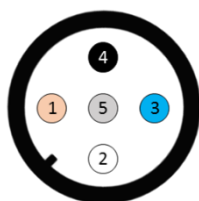

Each number corresponds to the number in Table 5-2.

Figure 5-9. Connector pin number of the MS-57SH

5-5. Measurements

1. Data logger settings

The output signal of pyrheliometer is measured by a measuring device such as a data logger. If solar irradiance is measured continuously, it is recommended to use a data logger, which has sufficient memory to record data over a longer period and functions to process the measurement parameters of the pyrheliometer. Depending on the sensor output which will be used, the data logger should be capable to measure the assigned output type.

For the MS-57SH with digital output, Modbus RTU or SDI-12, the data logger should have those inputs. For the MS-57SH the input range, resolution and impedance are not critical, and considered as standard for any meteorological or industrial type data logger.

When configuring the data logger parameters, the sampling rate and data reduction methods can be defined right at the beginning of the data acquisition process. The response time that is given in the specifications of the EKO pyrheliometers states the amount of time, which is necessary to reach 95% of the final measurement value. It is also possible to define a 63.2% response [which is equal to $1-1/e$]. This time constant, represented by the symbol τ , is 3 times smaller than the values specified by EKO. The recommended ^[1] sampling rate for pyrheliometers is smaller than τ . So, for EKO pyrheliometers, the sampling rates that have to be programmed in the data logger systems should not exceed the values as given in Table 7-1.

Performing averaging and/or integration of measurement data can be meaningful to, e.g., reduce the data volume or to meet application-specific requirement. Note that shorter sampling rates allow to use shorter averaging/integration times [In case of the MS-57: 10 Hz sampling rate, 1 minute averaging period]. It could also be meaningful to store not only average values, but to keep track of all statistical values during the averaging period, namely: average, integral, minimum and maximum values, and standard deviation. As a general recommendation, the averaging/integration period should be as short as possible, but long enough to reduce the data volume to store the processed data safely.

Recommendations for irradiance measurements are explained in ^[1]'Guide to Meteorological Instruments and Methods of Observation', WMO reference document No. 8.

2. Pyrheliometer default settings

The MS-57SH features a digital smart processing interface providing advanced measurement functions with different industrial signal outputs (**Modbus RTU, SDI-12**).

Where to find information regarding the MS-57SH defaults settings and important parameters:

Table 5-3. Where to find the settings?

MS-57SH	Defaults setting and parameters
Sensitivity figure	<ul style="list-style-type: none"> - Calibration certificate - Modbus register - SDI-12 register
Modbus RTU	<ul style="list-style-type: none"> - Setting report (see appendix A-8 of the MS-57SH setting report) - Modbus register <ul style="list-style-type: none"> o Address (last two digits of serial number, 100 if '00') o Baud rate 19200 o Parity Even
SDI-12	<ul style="list-style-type: none"> - Setting report (see appendix A-8 of the MS-57SH setting report) - SDI-12 register <ul style="list-style-type: none"> o Address 0 o Baud rate 1200 o Parity Even
Window heating function[*] (Default ON)	<ul style="list-style-type: none"> - Setting report - Modbus register

(*) The window heating function is set to ON when the product is shipped. The function can be switched ON/OFF via Hibi or by rewriting the registers of Modbus RTU and SDI-12 respectively. See the following section for details on the operating procedure.

A-3. Software (Hibi) 3. Software 5) Setting items 3.'DOME HEATING' setting items

A-4. Communication Specifications (Modbus RTU) A4-10. No. 101 or later registers

3. Calculate Direct Normal Incidence Solar Irradiance

The direct normal incidence solar irradiance is calculated from the measured output voltage according to the following linear expression.

$$I = E/S$$

I	[W/m ²]:	Direct Normal Incidence solar irradiance
E	[μV]:	Output voltage of the sensor
S	[μV/W·m ⁻²]:	Sensitivity (Indicated on the calibration certificate)

MS-57SH [Modbus RTU Output, SDI-12 Output]

When using the digital output (Modbus or SDI-12) by default the irradiance conversion is performed on-board and will be outputted as one of the measurement parameters within the data string.

4. Calculate Direct Horizontal Incidence Solar Irradiance

The direct horizontal incidence solar irradiance is calculated from the measured output voltage according to the following linear expression.

$$I_{hor.} = I \cdot \sin \theta$$

θ	[°]:	Solar Elevation Angle
----------	------	-----------------------

6. Maintenance & Troubleshooting

6-1. Maintenance

Using the MS-57SH, accurate results can be obtained if the quartz window and the condition of the instrument are maintained properly. Regular maintenance and scheduled re-calibrations can also extend the lifetime of the pyrliometer. However, environmental conditions, can have a deteriorating effect on the materials. Therefore, proper maintenance, adapted to the local environmental conditions, is required.

The following table describes the common maintenance tasks that should be performed on a regular basis:

Table 6-1. Maintenance Items1

Maintenance Item	Frequency	How To	Effect
Clean Quartz Window	Several times per week	Keep the quartz window clean by using demineralized water and wiping with a soft cloth dry and clean.	The irradiance measurement will be affected due to a change in transmittance.
Check Appearance Condition	Weekly	Check for cracks and scratches on the quartz window and body.	May lead to shade on the detector and enhanced soiling.
Check Sight spot	Weekly	Sometimes rain and dirt maybe collected in the through-hole for the sight and the sight spot cannot be confirmed. Clean and remove the water and/or dirt by using a small diameter pin.	The pyrliometer will not be able to accurately measure direct solar irradiance.
Check Cable Condition	Weekly	Verify if the cable connector is properly connected, tightened to the instrument, and how the cable is lined; make sure the cable is not shaking from the wind.	A disconnected cable will cause sporadic reading errors or failure of operation. If the cable is damaged, it may lead to noise or electric shock.
Check Setup Base Condition	Weekly	Check if the pyrliometer is tightened properly to the mounting plate is securely fastened in a proper condition.	Loose instruments and/or mounting plates can lead to damages of the instruments and/or injury.
Recalibration	Every 5 Years	To maintain the best possible measurement accuracy, recalibration of the pyrliometer is recommended. Contact EKO for more details and requests for a recalibration and maintenance service.	Due to natural aging of materials the detector sensitivity of the pyrliometer can gradually change over time.

Table 6-2. Maintenance Items2 (Advanced remote checks can be done on the MS-57SH)

Maintenance Item	Frequency	How To	Effect
Data validity	Weekly	Check the daytime irradiance data and compare to previous days or adjacent pyrhemometers.	When large difference occurs operating problems or installation issues can be detected.
Presence of noise	Weekly	Check night-time irradiance values	Night-time offsets and sensor stability issues can be revealed.
Check the temperature Inside	Weekly	Check the body temperature via Modbus RTU or SDI-12 output.	If the inside temperature becomes abnormally high, the life of the product will be shortened.
Check the effect of desiccant	Weekly	Check the internal relative humidity alert status of the pyrhemometer via Modbus RTU or SDI-12 output.	The condition of the drying agent can slightly change over time. If the relative humidity becomes high, the quartz window might be fogging up.
Window heating current	Weekly	Check window heating current alert register via Modbus RTU or SDI-12 output.	When the window heating function is turned on, if the window heating current is not energized properly, the dew and frost mitigation effect cannot be fully achieved.

6-2. Calibration and Measurement Uncertainty

It is recommended to recalibrate the instrument once every 5 years (*). For further information about recalibration and maintenance procedures, please contact EKO or find out more on the EKO website [eko-instruments.com].

1. Calibration Method

The MS-57SH is calibrated under natural sunlight against the EKO instruments reference pyrheliometer which is traceable to the World Radiation Reference (WRR) maintained at the World Radiation Center (PMOD) in Davos (CH).

Both MS-57SH and reference pyrheliometer are mounted on a Sun Tracker to capture the direct solar radiation. The direct solar radiation is measured based on 1 minute averaged value for total of more than 2 hours both in the morning and the afternoon on a clear day. The calibration value of the subjected pyrheliometer was obtained by multiplying the sensitivity value [$\mu\text{V}/\text{W}\cdot\text{m}^2$] of the reference pyrheliometer with the averaged ratio of the measured total direct irradiance data. To improve the calibration accuracy and minimize the measurement uncertainty several operating criteria are applied.

(*) When there is no condensation inside of the body.

2. Calibration Uncertainty and Traceability

The criteria for the operating conditions like the indicated ambient temperature, minimum direct radiation and minimum solar elevation angle are applied to minimize the overall uncertainty in the calibration. The pyrheliometer uncertainty figure is statistically calculated based on a standard deviation of (1.96σ) , which means that 95% of the measured direct irradiance values agree with the reference pyrheliometer.

The reference pyrheliometer will be calibrated at every 2 years against a primary standard pyrheliometer, called absolute cavity pyrheliometer. The absolute cavity pyrheliometer is directly traceable to the WRR (World Radiometric Reference) and maintained in the group of standard radiometers calibrated every 5 years during the IPC (International Pyrheliometer Comparison), as well as by NPC (NREL Pyrheliometer Comparison), which is held every year.

The data acquisition system is traceable to JEMIC (Japan Electric Meters Inspection Corporation).

6-3. Troubleshooting

This section contains information that can be used to make a failure diagnosis whenever the sensor does not function properly. Contact your distributor or EKO for any further technical support.

Table 6-3 Troubleshooting

Failure	Action
There is no output.	Make sure that the sensor is properly connected, and type of power supply and voltage values are appropriate. Also check the communication settings [i.e., port, baud rate, converter ID] are appropriate.
Output value is too low	The quartz window maybe soiled with rain or dust. Clean the quartz window with demineralized water and soft cloth. The output may decrease over time. Recalibrate periodically.
Negative output signal during night-time.	Pyrheliometer generate an output signal, which is proportional to the temperature differences between the sensor's so-called hot and cold junctions. Night-time offset can occur when the window temperature will cool down below the temperature of the detector. A slight negative offset within the specification can be expected.
Unusual noise	Check the shield connection and make sure it is connected securely. Make sure if the output cable is not shaking from the wind; take necessary measure by fixing or lining the cables through metal pipe. Check for any objects, which emit electromagnetic wave around the instrument and or the cable.
Window heating current alert	Check that the power supply voltage of the pyrliometer is not less than 8VDC. (A power supply of 8VDC or more is required to use the window heating function.)

Table 6-4. Troubleshooting Hibi

Failure	Action
No connection with PC	Make sure that the sensor is properly connected, and power supply and voltage levels are appropriate. Also check the communication settings [i.e., port, baud rate, converter ID] are correct.
No communication with USB cable	If no COM port shows up when Hibi software is started. <ul style="list-style-type: none"> - Reconnect the USB converter and refresh to search new COM devices - Check for COM port settings in Windows settings - Install an appropriate driver
Settings changes not saved to pyrliometer	Make sure that the sensor is properly connected, and power supply and voltage levels are appropriate. Also check the communication settings [i.e., port, baud rate, converter ID] are correct. Power off/on the pyrliometer, some of the settings are effective after power off/on.

7. Specification

7-1. Specifications

Table 7-1 Specification: Specifications are indicated as typical values.

Characteristics ⁽¹⁾	ISO9060: 2018	MS-57SH
	(ISO9060: 1990)	Class A
	Spectrally flat	(First class)
	Fast response	Compliant
Response time 95% output	< 10 Sec	< 0.3 Sec
Response time 99% output	---	< 0.5 Sec
Zero off-set a) 5K/hr	$\pm 1 \text{ W/m}^2$	$\pm 1 \text{ W/m}^2$
Total zero off-set b)	$\pm 2 \text{ W/m}^2$	$\pm 1 \text{ W/m}^2$
Non-stability	$\pm 0.5 \text{ \% / 1yr}$	$\pm 0.5 \text{ \% / 5yrs}$
Non-linearity	$\pm 0.2 \text{ \%}$	$\pm 0.2 \text{ \%}$
Spectral error	$\pm 0.2\%$	$\pm 0.2\%$
Spectral selectivity	$\pm 3 \text{ \%}$	$\pm 1 \text{ \%}$
Temperature response -10 to +40°C	$\pm 0.5 \text{ \%}$	$\pm 0.5 \text{ \%}$
-30 to +60°C	---	$\pm 0.5 \text{ \%}$
-40 to +70°C	---	$\pm 1 \text{ \%}$
Tilt response	$\pm 0.2 \text{ \%}$	$\pm 0.2 \text{ \%}$
Signal processing errors	$\pm 1 \text{ W/m}^2$	$\pm 1 \text{ W/m}^2$
Expected Daily Measurement Uncertainty	---	$\pm 1\%$

(1) The content of the characteristic item is partly changed from ISO 9060: 1990. Please also refer to "A-2. Pyrheliometer Characteristics"

Table 7-2. Other Specification

Characteristics	MS-57SH
Field of View	5°
Wavelength Range	200 –4000nm
[1] Operating Temperature	-40 to +80 °C Accuracy guaranteed temperature range: -40 to +70°C
[2] Maximum Irradiance	4000W/m ²
Digital signal output	-200W/m ² to +2000W/m ²
Tilt sensor accuracy	<±1°
Humidity sensor accuracy	Nominal: ±2%RH
Temperature sensor of PCB (tolerance)	±0.5°C
Detector temperature sensor	Pt100 Class A [3]
Detector temperature sensor accuracy	±0.5°C
Environmental protection [IP Code]	IP 67[IEC60529]
Sensitivity	Approx.7μV/W·m ²
Cable Length (Standard)	10 m
Weight (Including 10m cable)	0.6kg (1.6 kg)
Output cable [Outer diameter]	AWG22 0.3mm ² x 5 pins [φ5.3-5.7mm]
Output cable terminal	Pin-Terminal [0.3-9.5]
Output [or Signal]	Modbus RTU, SDI-12
Resolution	< 0.01W·m ⁻²
Alert signal	Alert is issued when the internal humidity and current of the window heating of the pyrheliometer is abnormal.
Input power supply	Modbus RTU: DC5V±5% (USB BusPower) ^[4] Without window heating function or DC8V to DC30V±10% ^[5] With window heating function SDI-12 : DC12V±10% With/without window heating function
Power consumption	With heating : < 1.4W Without heating : < 0.2W

[1] When the instrument is used in the ambient temperature exceeding the accuracy assurance temperature range, the measurement error may increase.

[2] The operational maximum irradiance is defined as the maximum irradiance exposure level. Beyond this point damage may occur to the sensor.

[3] Temperature sensor is internally connected to Modbus electronics.

[4] Sensor setting can be changed by connecting the sensor to a PC (Use the EKO Converter Cable (option) and download the free configuration software from the EKO website.

[5] Although the MS-57SH can operate from a DC 8V power supply, a DC 12V power supply or higher is recommended for long-term stable operation of the pyrheliometer, including the window heating function.

Table 7-3. Power consumption supply voltage specific (Without window heating function)

	5V DC	12V DC	24V DC	Remarks
During stand-by	75mW (Approx. 15mA)	90mW (Approx. 7.5mA)	110mW (Approx. 4.5mA)	-
Modbus RTU	170mW (Approx. 34mA)	180mW (Approx. 15mA)	190mW (Approx. 8mA)	Peak value during communication

Table 7-4. Power consumption supply voltage specific (With window heating function)

	12V DC	24V DC	Remarks
During stand-by	1.1W (Approx. 90mA)	1.1W (Approx. 43mA)	-
Modbus RTU	1.1W (Approx. 95mA)	1.1W (Approx. 46mA)	Peak value during communication

7-2. Dimensions

Table 7-5. Dimensions

	MS-57SH
A. Length	233 mm
B. Rain cap diameter	Φ55 mm
C. Diameter of Fixing Area	Φ38 mm
D. Width	Φ68 mm
E. Overall Height	80.5mm

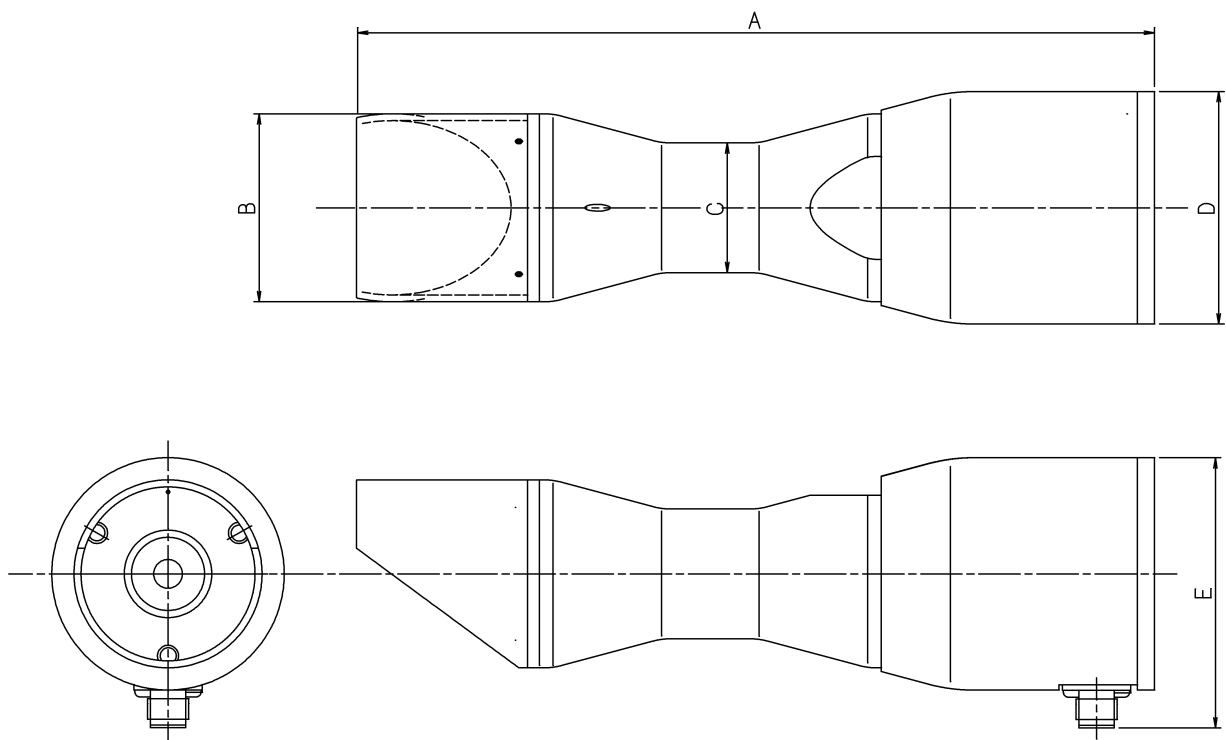

Figure 7-1. MS-57SH Outer Dimensions

7-3. Output Cables

See [5-2. Setup, 5-3. Wiring] for instruction

1. MS-57SH

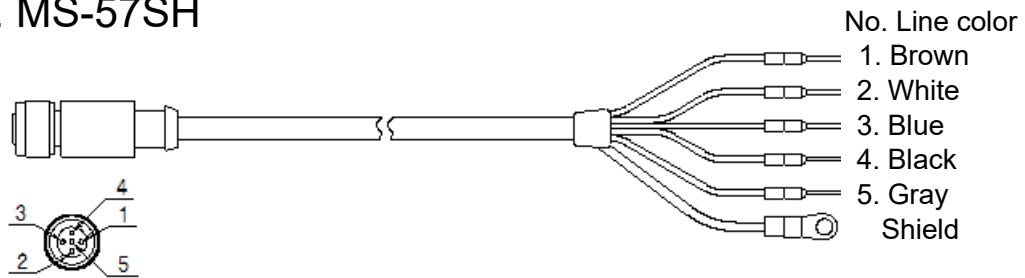

Figure 7-2. Output Cables

2. EKO Converter Cable (Option)

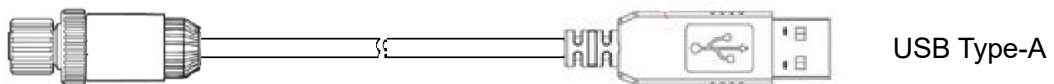

Figure 7-3. EKO Converter cable

7-4. Accessories List

Table 7-6 Accessories List

Accessories	Details
Cable Length*	20, 30, 50m
EKO Converter Cable	Converts from RS485 → USB for the communication with the MS-57SH and allows to connect to PC via USB terminal. Cable Length:5m
STR-21/22 Mounting Jigs	Fixing Ring
	Mounting Plate (3-holes)

*Standard cable length: 10m

APPENDIX

A-1. Radiometric Terms

Table A-1. Definitions of Terms

Hemispheric Solar Irradiance	Cosine-weighted solar irradiance received over a solid angle of 2π sr on a plane surface, expressed in units of W/m^2 or kW/m^2 .
Global Solar Irradiance, Global Horizontal Irradiance (GHI)	Hemispherical solar irradiance received on a horizontal plane surface, expressed in units of W/m^2 or kW/m^2 .
Direct Solar Irradiance, Direct Normal Irradiance (DNI)	Normal-incidence solar irradiance received over a small solid angle which includes the circum solar irradiance, expressed in units of W/m^2 or kW/m^2 .
Diffuse Solar Irradiance, Diffuse Horizontal Irradiance (DHI)	Hemispherical solar irradiance without the direct solar irradiance, i.e. indirect irradiance of the scattered solar radiation (by air molecules, aerosol particles, clouds, etc.), expressed in units of W/m^2 or kW/m^2 .
Pyranometer	A radiometer designed to measure the hemispheric solar irradiance over the wavelength range of about 300 to 3,000nm.
Pyrheliometer	A radiometer designed to measure the direct solar irradiance over a certain solid angle including the circumsolar irradiance.
World Radiation Reference (WRR)	Radiometric reference instrument system which has an uncertainty of less than $\pm 0.3\%$, expressed in SI units. This reference is maintained by the World Meteorological Organization (WMO), and it has been issued since January 1, 1980
ISO9060	An ISO norm (International Standard). The first edition was published in 1990, then the second edition was revised in 2018. Based on the performance of each characteristic, Pyranometer is classified into three classes A, B, and C, and specifications of "Spectrally flat radiometer" and "Fast response radiometer" are set as sub-categories. Pyrheliometer is classified into 4 classes of AA, A, B and C based on the performance of each characteristic, and specifications of "spectrally flat radiometer" and "Fast response radiometer" are set as sub-categories.

A-2. Pyrheliometer Characteristics

Table A-2. Pyrheliometer Characteristics (see also CIMO Guide, WMO No. 8, 2008)

Response Time	The time (seconds) of a pyrheliometer sensor to reach 95% of its final output signal. (ISO 9060: 2018 added) If the response time reach to 95% is less than 0.5 seconds, "fast response" is attached to the applicable class as a subcategory.
Zero Off-Set a	Response (dark-signal) to 5K per hour change in ambient temperature
Total zero off-set b	(ISO 9060: 2018 added) Total zero off-set including the effects a) and other sources
Non-Stability	Rate of change [%] of the pyrheliometer sensitivity per year.
Nonlinearity	Percentage deviation from the responsivity at 500W/m ² due to any change of irradiance within the range 100W/m ² to 1,000W/m ² .
Spectral error	(ISO 9060: 2018 added) Maximum spectral mismatch error of Pyrheliometer [%] with respect to spectral irradiance at AM 1.5 and AM 5 under multiple atmospheric conditions on fine weather against the reference standard spectral irradiance defined by IEC60904-3: 2016 Photovoltaic devices - "Measurement principles for terrestrial photovoltaic (PV) solar devices with reference spectral irradiance data."
Spectral Selectivity	Percentage deviation of the product of spectral absorptance and spectral transmittance from the corresponding mean within the range 0.35µm to 1.5µm.
Temperature Response	(ISO 9060: 2018 modified) Percentage maximum output error due to any change of ambient temperature between -10 to 50°C against the output at 20°C.
Tilt Response	(ISO 9060: 2018 modified) Percentage deviation from the responsivity at 0° tilt (horizontal) due to change in tilt from 0° to 180° at 1,000W/m ² .

A-3. Software (Hibi)

'Hibi' means 'day by day' in Japanese, and with this program, users will be able to visualize detection signals, set communication parameters, and rapidly troubleshoot any issues from day one. You can change the settings of the MS-57SH using the Windows software downloadable from the EKO website and the optional USB cable.

1. Software Installation

Follow the steps below to install 'Hibi' configurator software.

- 1) Download the latest version of the 'hibi.zip' file [Compressed file: Zip format] on the EKO website.
- 2) Unzip 'hibi.zip' file and check that the 'setup.exe' file exists.
- 3) Run the 'setup.exe' file to install 'Hibi' configurator software.

2. Hardware Preparation

After the software is installed, connect the MS-57SH with a PC to change the setting.

- 1) After installing the software, connect the USB connector of 'RS485/USB Converter cable' to the PC.
- 2) Connect the ends of the signal cable of MS-57SH to the communication terminal of 'RS485/USB converter'.
- 3) Connect the power lines of the signal cable to the power supply (DC5V or 8 to 30V), and turn on the power supply. (Refer to Figure A3-1.)

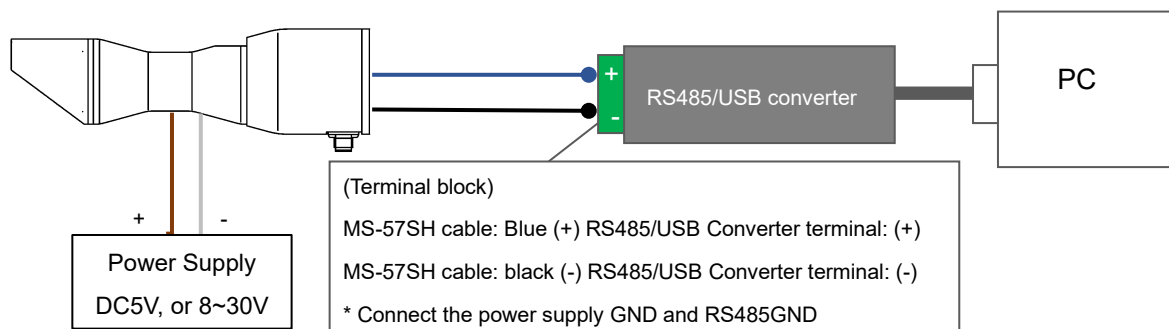

Figure A3-1. Hardware preparation

If you use the optional 'EKO Converter Cable', you can install it simply by inserting the cable connector into the main unit. Power for the MS-57SH can be supplied via USB. (See Figure A3-2).

* This conversion cable is for installation, so please avoid using it outdoors for a long time. Because the ground wire is not connected, surges can damage your PC during a lightning strike.

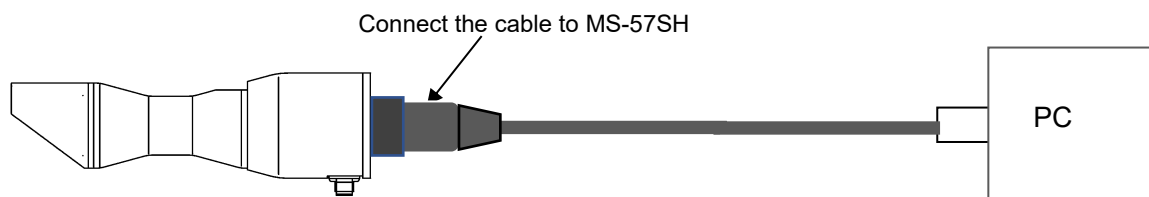

Figure A3-2. Using "EKO Converter cable"

3. Software

Start the 'Hibi' software and make the required settings.

- 1) Start 'Hibi' software. (Launch the software from 'hibi.exe' located in the shortcuts or installation folder.)
- 2) After the software starts, the 'Welcome' window appears.

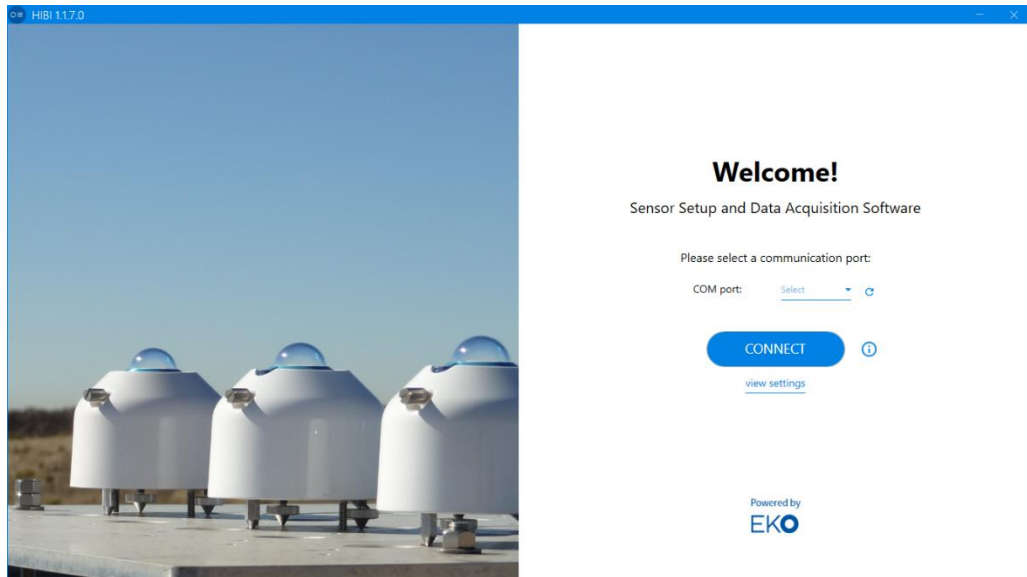

Figure A3-3. Welcome window

- 3) Automatic connection

When using the 'Auto-connect' function to connect the MS-57SH with the 'Hibi' software, select the COM port that the RS485/USB converter cable is connected to.

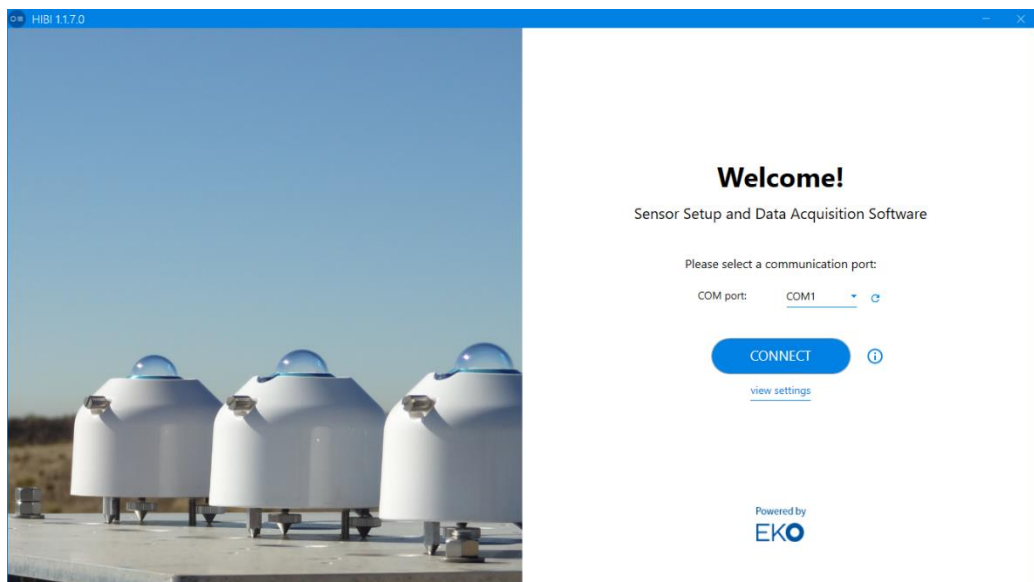

Figure A3-4. Com port select

Click 'Select' of 'COM port:' on the startup screen, and select the COM port number assigned to the RS485 / USB conversion cable from the displayed COM port numbers.

If you can't find a selectable COM port, click the Refresh button and click Select again to try again.

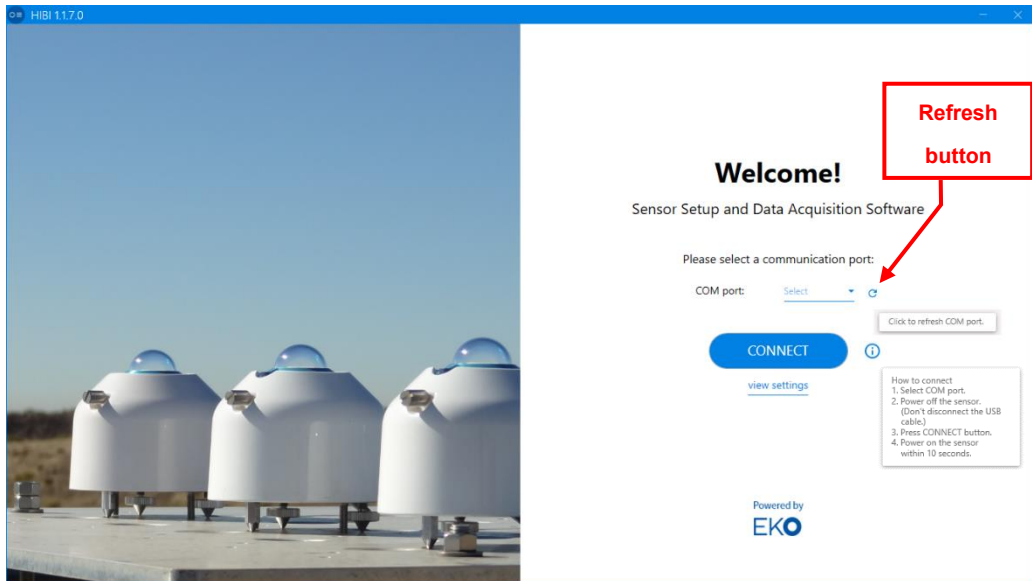

Figure A3-5. Com port select

Check that the power supply of the main unit is 'OFF'. Then, click 'CONNECT' button.

If the COM port is not recognized, press the refresh button and try again.

Power on the MS-57SH within 10 seconds once the 'Connecting your sensor' message appears.

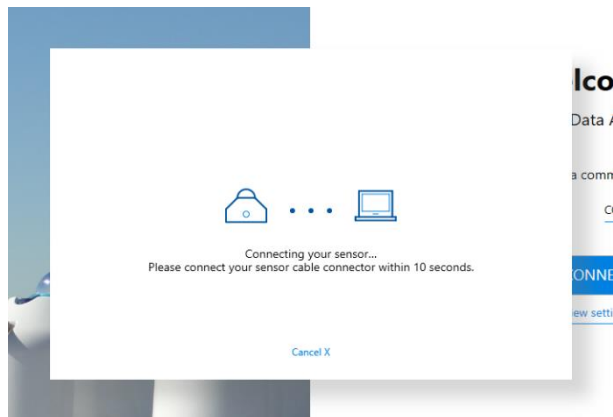

Figure A3-6. Connecting screen

When the connection is completed, the window automatically switches to the 'Dashboard' window. In the upper-right corner of the display changes to 'Pyrheliometer Connected'.

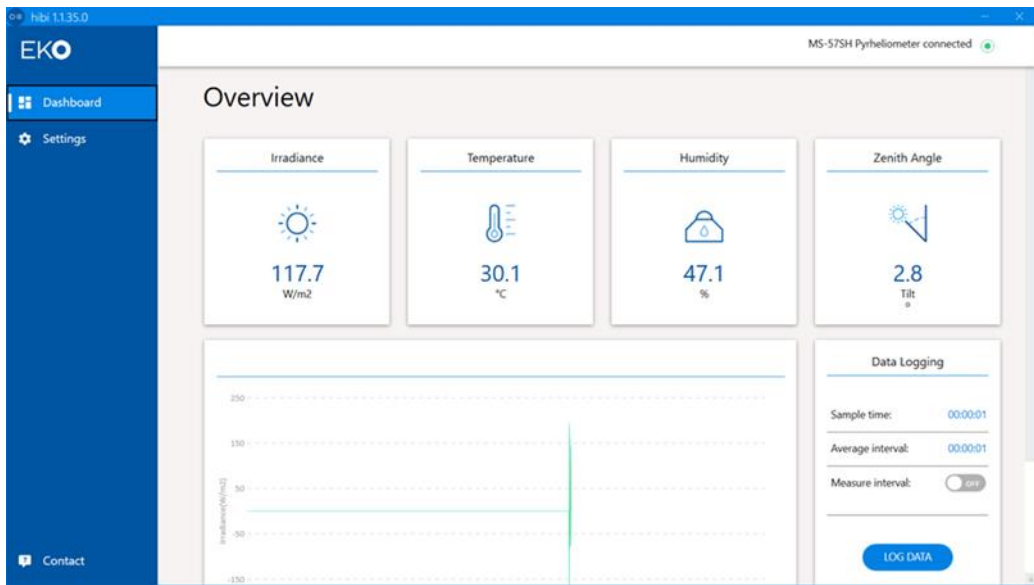

Figure A3-7. Dashboard

If the connection fails, the screen returns to the 'Welcome' screen and 'CONNECTION FAILED' is displayed.

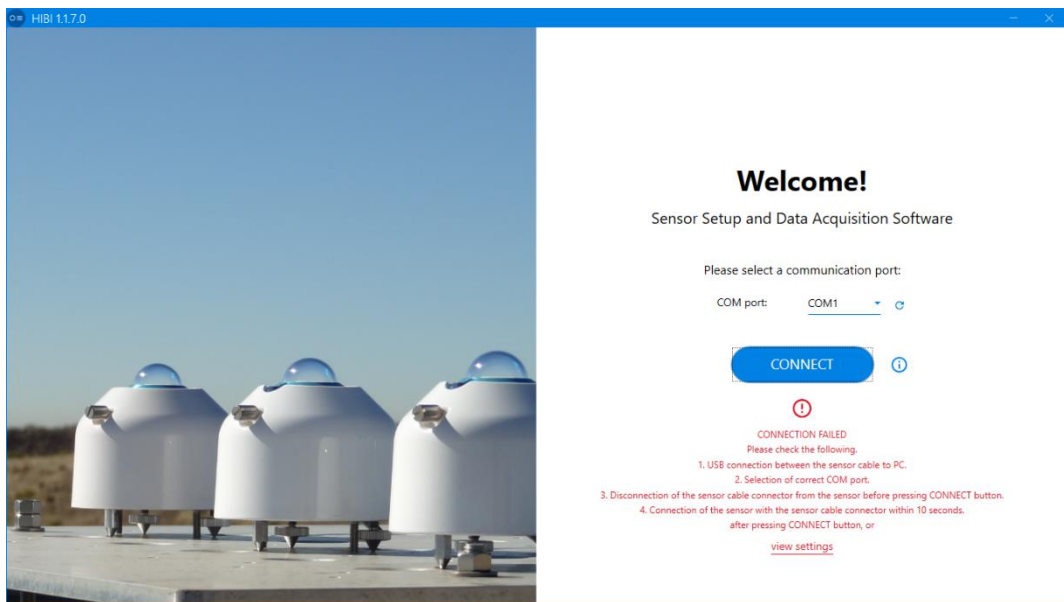

Figure A3-8. CONNECTION FAILED

Make sure the connection settings are correct. To perform the 'Auto-connection' again, turn off the power of the MS-57SH, select 'COM port', and then click 'CONNECT'.

For manual connections, click 'View settings' at the bottom of 'CONNECTION FAILED' to go to 'Settings screen'. (As for how to set and connect by 'Manual connection', refer to the procedures (4) Manual connection) from the next section.

4) Manual connection

After turning on the power of the MS-57SH, click 'CONNECT' without selecting 'COM port'.

Clicking 'view settings' at the bottom of the 'CONNECTION FAILED' screen moves to the 'Settings' screen. (The same screen appears even when the 'Auto-connection' fails. To perform manual connection, set and connect using this procedure.)

After setting up the communication settings, click the 'CONNECT' button in Connection status.

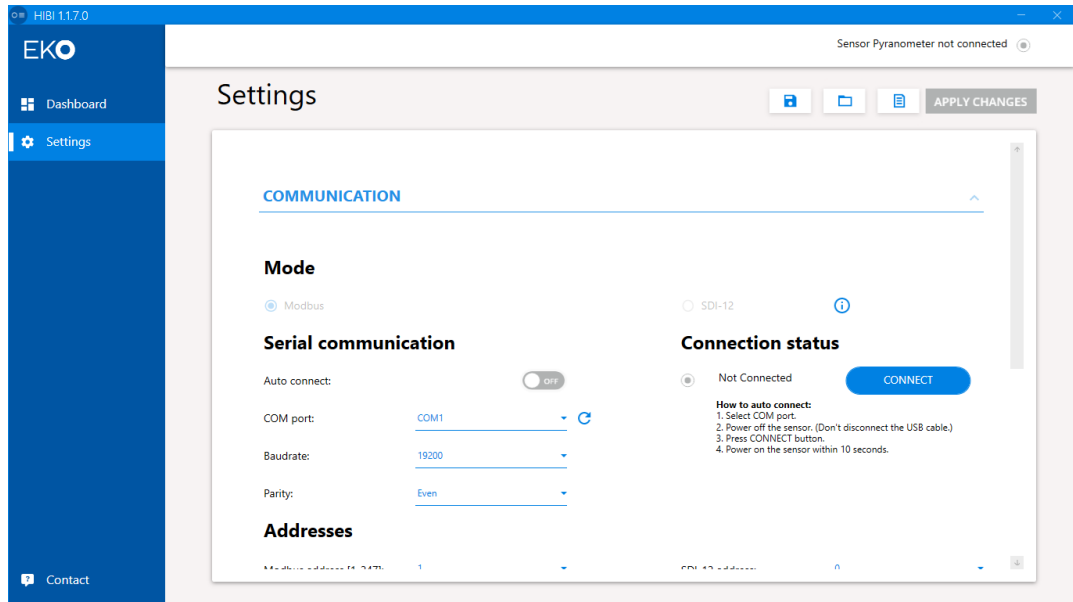

Figure A3-9. Manual connection

When the connection is completed, 'Connected' is displayed.

'MS-57SH Pyrheliometer Connected' is also shown in the upper-right corner of the display.

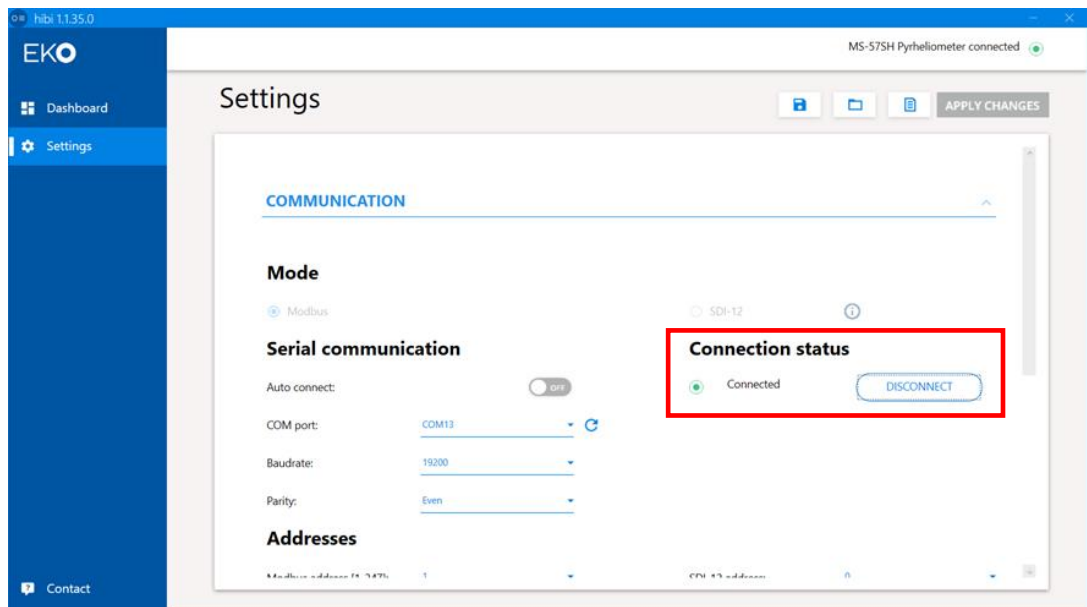

Figure A3-10. Disconnect appear

When the connection fails, the 'Oops...' screen is displayed with the cause of the connection failure.

When connection fail appears

Check that the cable connection, COM port and the communication requirements are correct.

When changing the connection condition after successful connection, set 'COM port', 'Baud rate' and 'Parity' in the 'Serial communication' setting of the 'COMMUNICATION' items and set 'Modbus address [1-247]' in the 'Addresses' setting.

After entering the settings, click 'APPLY CHANGES'

A confirmation window will be displayed.

Click 'YES, SAVE' to make the settings for the MS-57SH.

The settings in 'Settings' can be saved / read / exported to CSV files.

Click the button with icons in the upper-right corner of 'Settings' window.

- 'Save' button: Save the settings.
- 'Read' button: Read out the settings.
- 'Output' button: Output the settings to CSV file

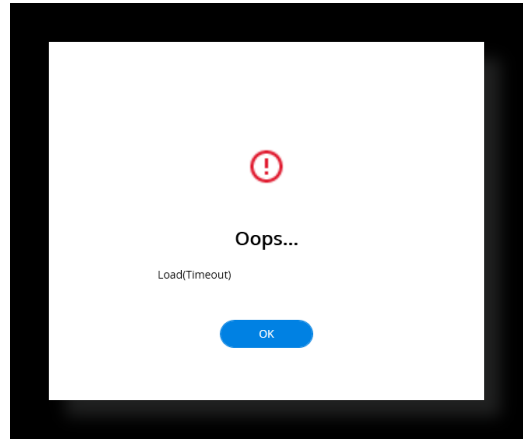

Figure A3-11. Oops screen

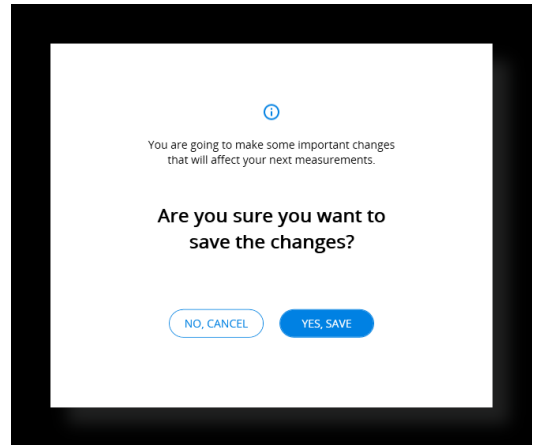

Figure A3-12. Apply changes screen

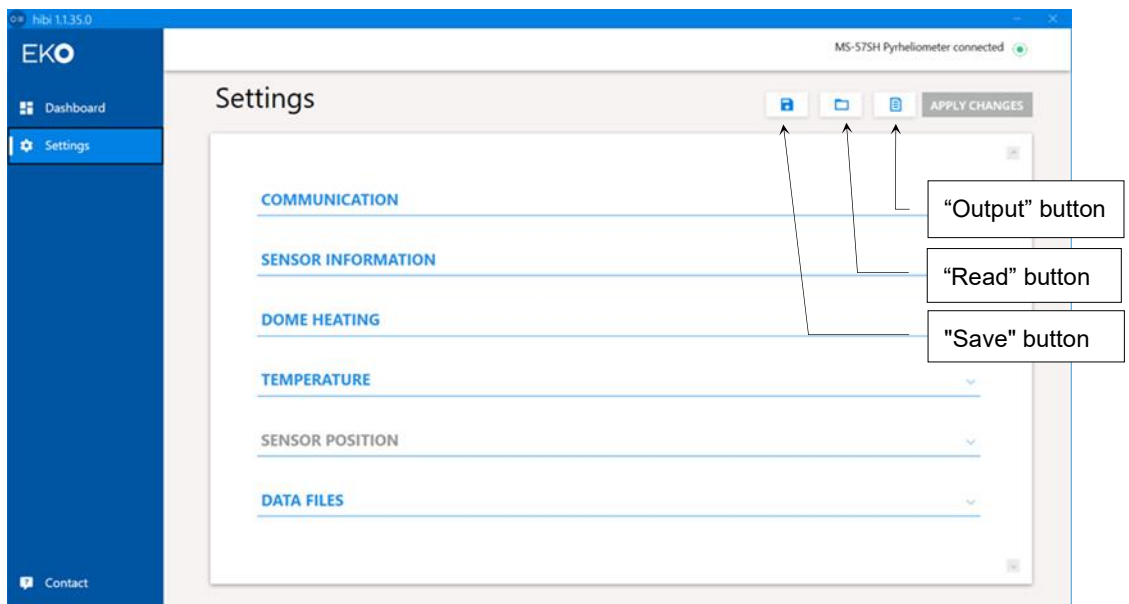

Figure A3-13. Settings screen

5) Setting items

1. COMMUNICATION setting items

Item name	Setting contents	Setting range
Mode(*)	-	Automatically switches to each mode by wiring
	-	(→ see 5.4)
Serial communication	Auto search	OFF/ON: Manual-connect / Auto-connect
	COM Port	COM1 to COM256
	Baud rate	2400 / 4800 / 9600 / 19200 / 38400 / 115200bps
	Parity	Even / Odd / None
Addresses	Modbus address [1-247]	1 to 247 (last 2 digits of serial number is default address, 100 when '00')
	SDI-12 address	0 to 9 / A to Z / a to z
Connection status	---	Connected / Disconnect

(*)Mode setting cannot be used for MS-57SH as mode is changed by signal cable wiring.

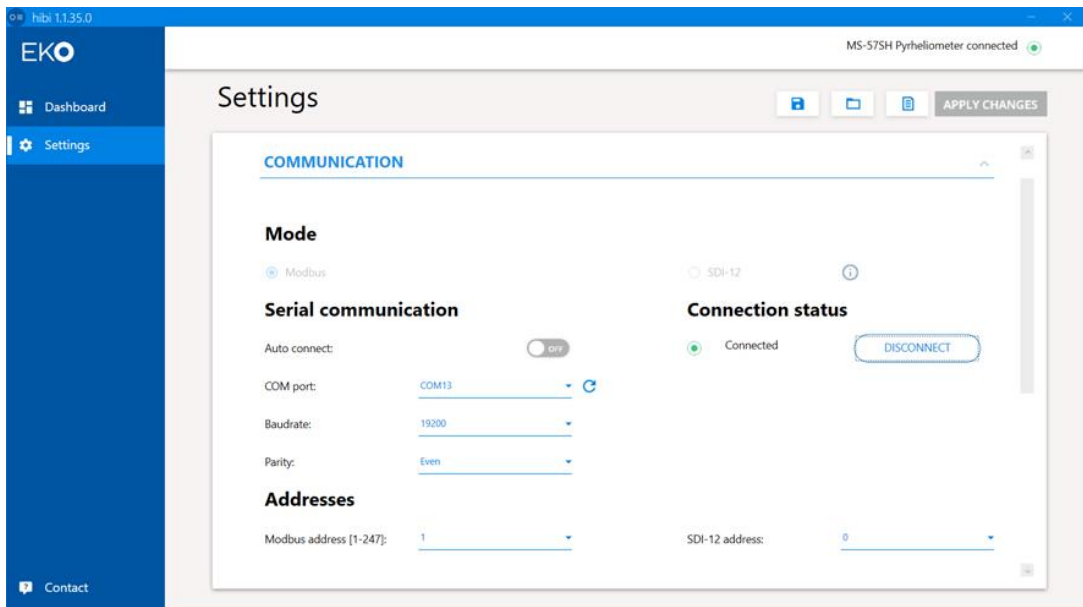

Figure A3-14. Communication setting screen

2. 'SENSOR INFORMATION' setting items

Item Name	Setting contents	Setting range
Model information	Model	Model name registered in the MS-57SH (cannot be changed)
	Serial number	Serial number registered to the MS-57SH (cannot be changed)
	MFG. date	Date of manufacturing (cannot be changed)
	Firmware version	Firmware version of MS-57SH (cannot be changed)
	Hardware version	Hardware version of MS-57SH (cannot be changed)
Calibration	Calibration date	Calibration date and time: Registered at the time of calibration by the manufacturer, but can also be registered by the user.
	Sensitivity [$\mu\text{V}/\text{W}/\text{m}^2$]	Sensitivity constant: Registered at the time of manufacturer calibration, but can also be registered at the user side.

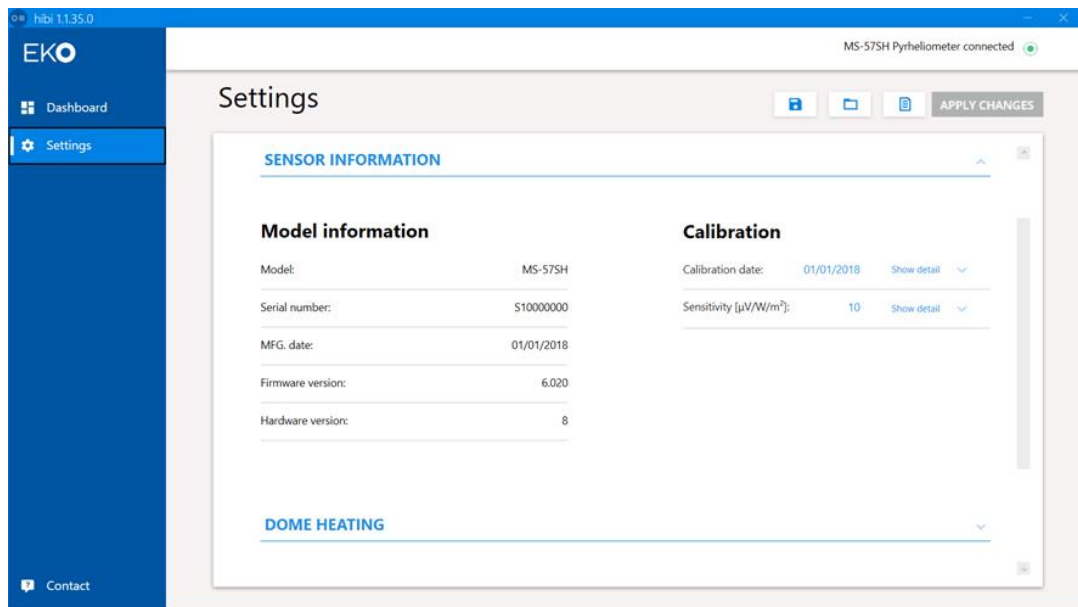

Figure A3-15. Sensor information settings

3. 'DOME HEATING' setting items

Item Name	Setting contents	Setting range
DOME HEATING	Enable DOME HEATING	DOME HEATING OFF/ON (selected with the radio button) * Default is ON.

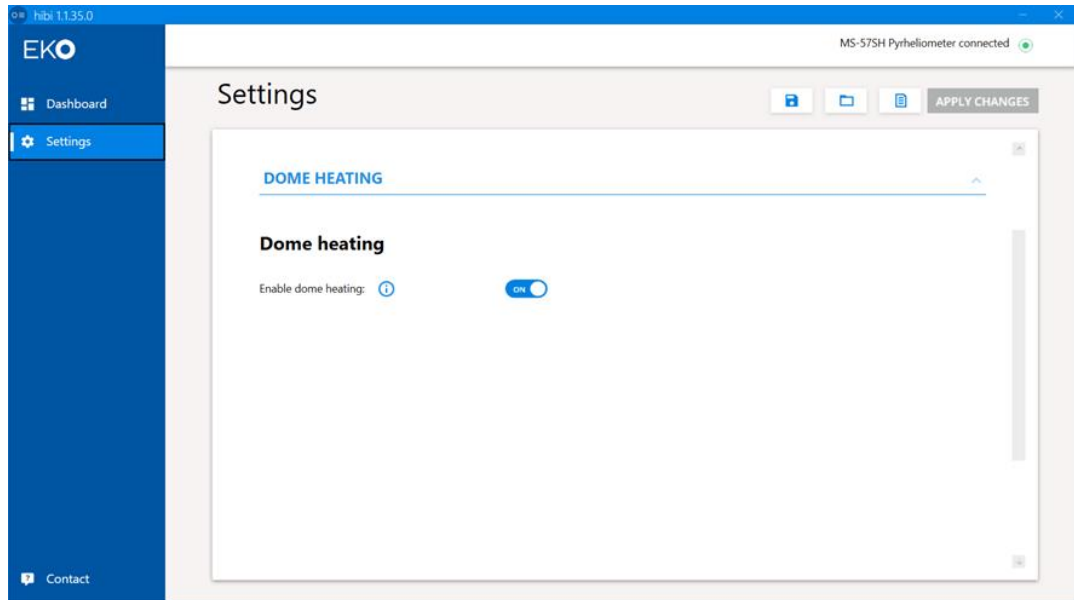

Figure A3-16. DOME HEATING settings screen

4. 'TEMPERATURE' setting items

Item Name	Setting contents	Setting range
UNIT	Preferred unit (Temperature unit setting)	°C -Celsius / °F -Fahrenheit / K-Kelvin

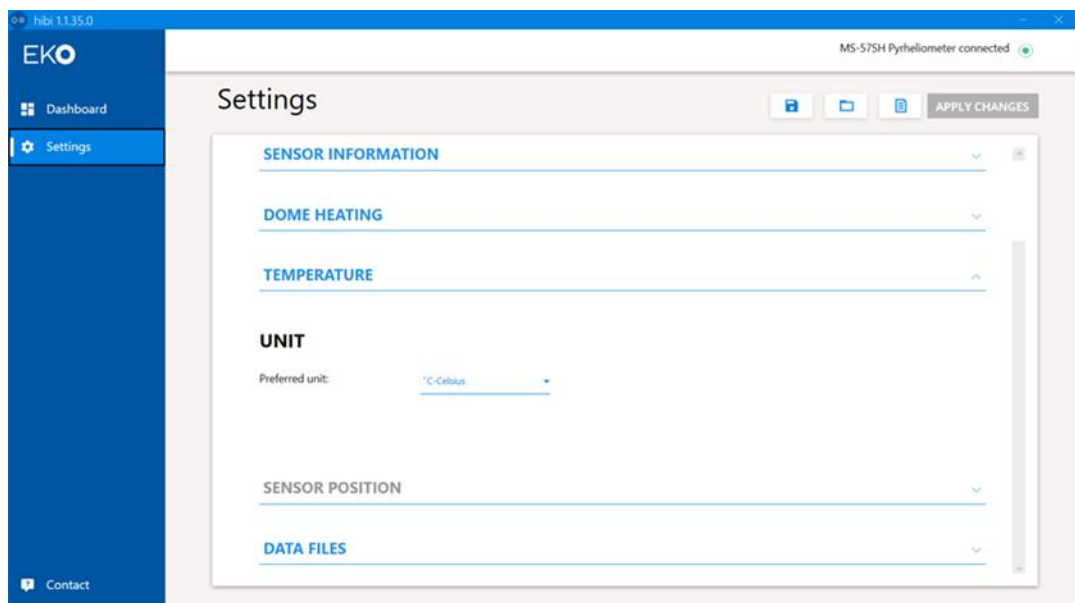

Figure A3-17. Sensor settings screen

5. 'SENSOR POSITION' setting items (cannot be settings)
'SENSOR POSITION' is pre-set at the factory.

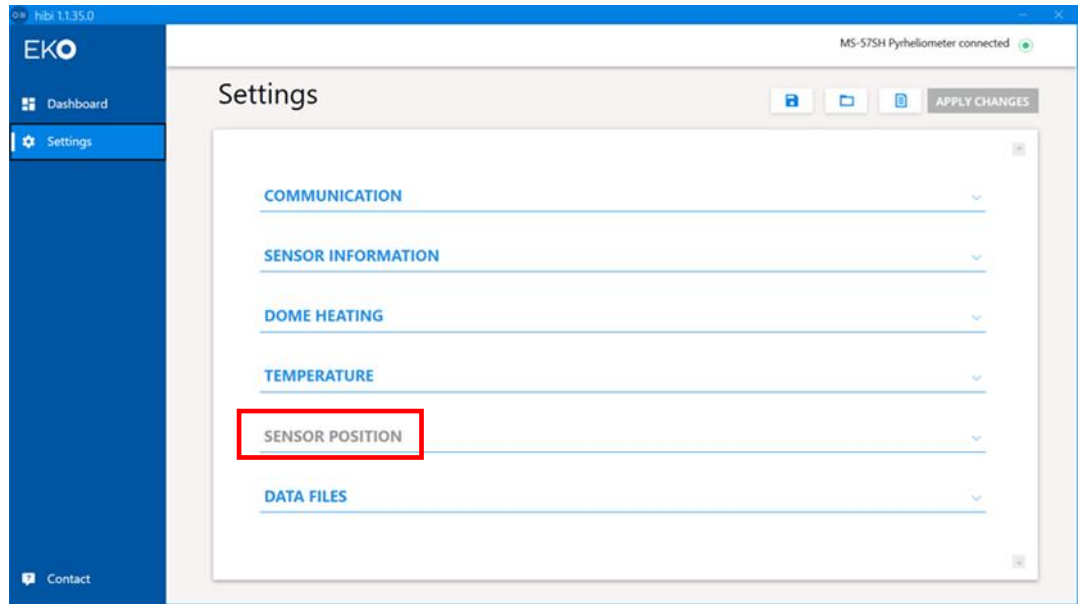

Figure A3-18. Sensor Position setting

6. DATA FILES setting items

[Measurements]

<Save file to> Enter the name of the measurement data storage folder.

[Sensor settings]

<Save file to> Enter the name of the setting file storage folder.

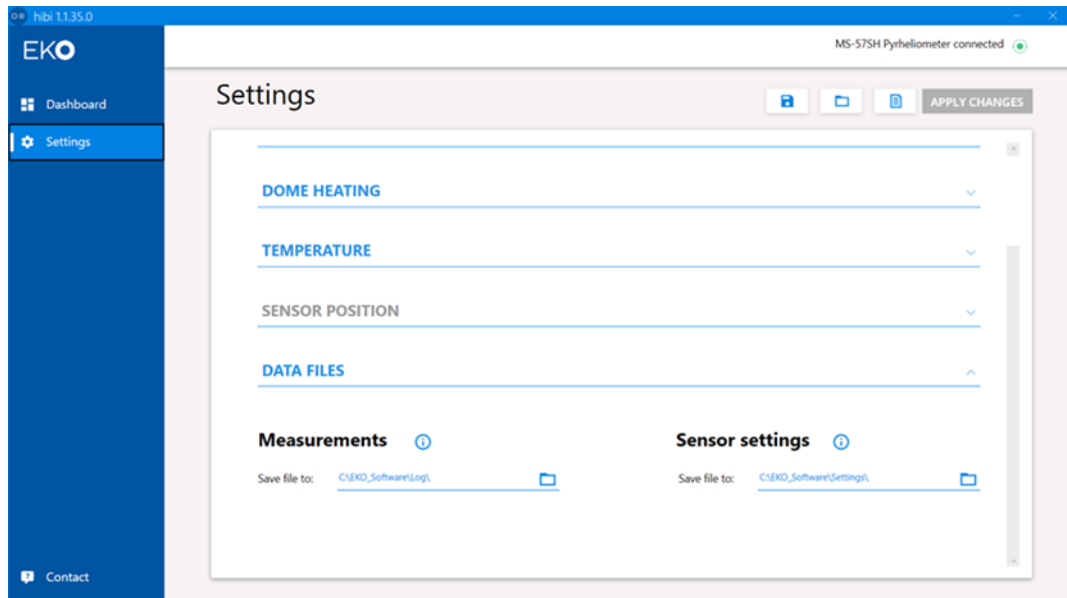

Figure A3-19. Data Files setting

6) Measurement (Dashboard)

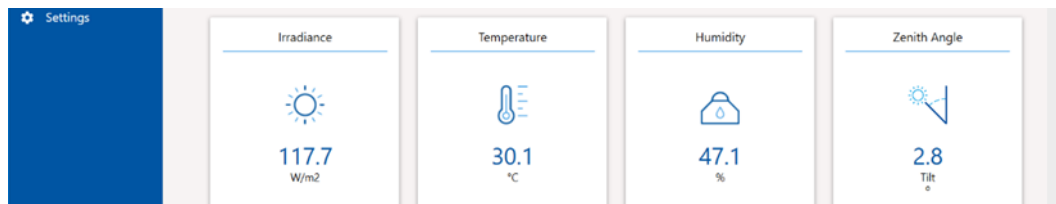

Figure A3-20. Dashboard screen

[Overview]

- Measurement data for irradiance, temperature, humidity, and zenith angle are read from the MS-57SH every 1 second and displayed.

<Irradiance> Irradiance measurement data (Unit: W/m²)

<Temperature> Internal temperature measurement data.

Unit: selected from °C (Celsius), °F (Fahrenheit) or 'K (Kelvin)'. (°C: default)

<Humidity> Humidity measurement data (Unit: '%RH')

<Zenith Angle> Zenith angle data

[Real-time measurement view]



Figure A3-21. Real-time measurement view

<Real time measurement-Irradiance>

- Display measured irradiance data in a graph (1-second update).
- Drag the graph to change the horizontal axis position and use the mouse wheel to zoom in or out on the desired area.
- The time range of the graph is 00:00:00 to 23:59:59.
- Clicking 'Back to default' resets the change of the setting of the graph.

<Data Logging>

Logging function of measurement data

'Sample time:' Set the logging interval for measurement data.

Setting range: 00:01~01:00 (1 sec to 1 min)

'Average interval:' Set the logging interval for averaged measurement data.

Setting range: 00:01~01:00 (1 sec to 1 min)

'Measure intervals:' Set the time interval for data logging.

By checking 'Continue next days', it is also possible to keep setting after the next consecutive days.

'Start at:' Set the start time for data logging.

'Ends at:' Set the end time for data logging.

* Setting across the day is not possible. The start time must be earlier than the end time. (Start time < End time)

'LOG DATA buttons:' Click to start logging measurement data.

When 'STOP' is clicked while measurement data is being logged, logging stops.

7) Contact (Contact)

When you click the 'Contact' button, the contact page on [EKO Instruments] website appears in the Browser.

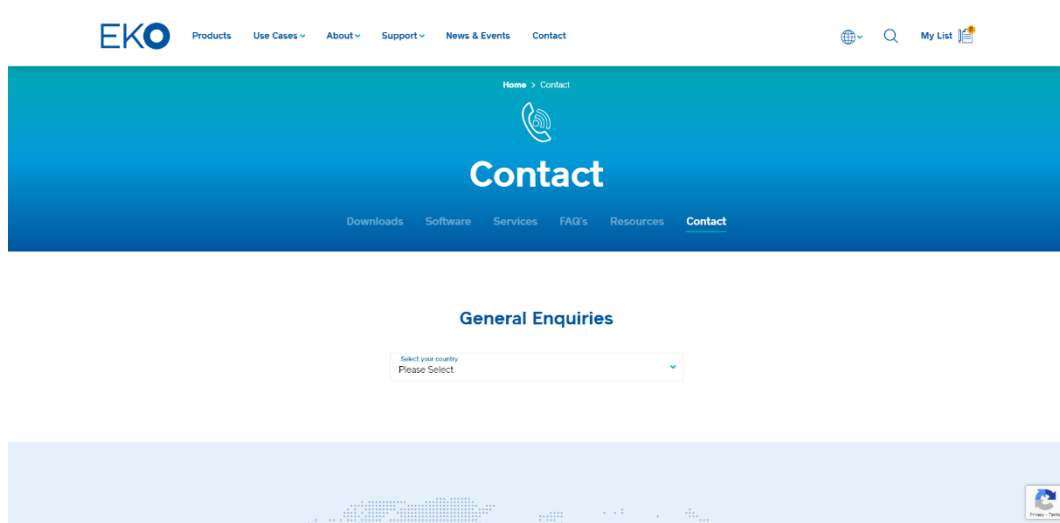

Figure A3-22. Contact page @ eko-instruments.com

8) Sensor internal humidity abnormality alert

Hibi has a function to monitor the relative internal humidity of the pyrhelimeter at all times. When the internal relative humidity exceeds the standard value due to external failure or deterioration of drying agent over time, Hibi judges it to be abnormal and displays an alert. If a pyrhelimeter is left as is after the alert, the possibility of a problem such as condensation inside the pyrhelimeter quartz window will increase, so please contact EKO.

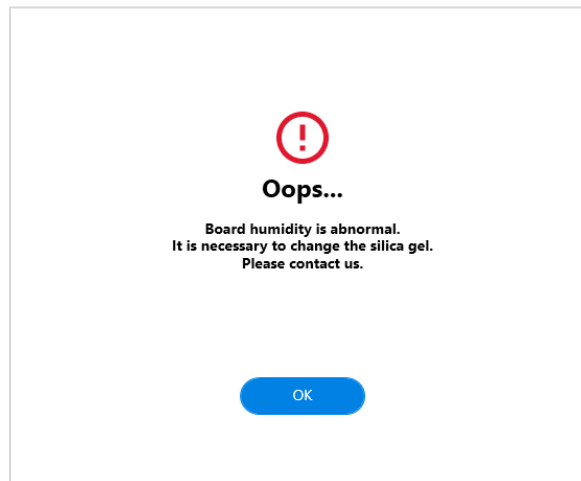

Figure A3-23. Sensor internal humidity abnormality alert

9) Recalibration recommendation notice

If Hibi detects that 5 years (1825 days) have passed since the initial calibration date, a recalibration recommendation notice will appear.

If the above notification is displayed, please contact EKO for recalibration.

* In the case of leap years, notifications will be displayed from the day before.

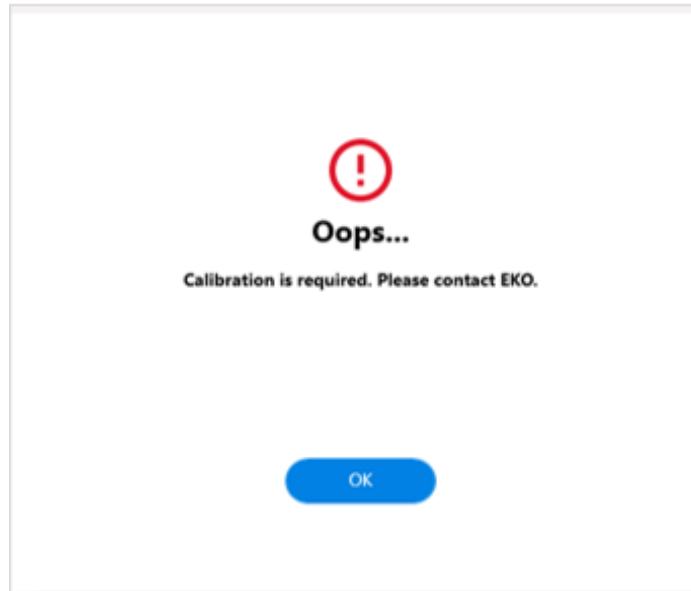

FigureA3-24. Recalibration recommendation notice

10) Exiting the software (Hibi)

To exit Hibi, click the 'X' in the upper-right corner of the window.

A-4. Communication Specifications (Modbus RTU)

A4-1. Outlines

- This device is compatible with Modbus RTU*. ASCII modes are not supported.
(* This is an open protocol for serial communication developed by Modicon.)
- The initial setting of the communication interface is Modbus RTU mode. To use the SDI-12 mode, change the settings from 'Hibi' software. After changing the setting, turn the power off and then on again to operate with SDI-12. To return to Modbus RTU mode again, change the setting from 'Hibi' software.
- It corresponds to RS485, half-duplex and double-wire multi-drop networks.

The communication specifications are as follows.

Table A4-1. Modbus RTU communication protocol

Optional item	Remarks
Electrical specifications	EIA-485
Connection form	Multi-drop method (1 for Master, 31 for Slave, 32 for total)
Communications protocols	Modbus RTU *1 (Slave)
Communication speed baud rate	2400, 4800, 9600, 19200 , 38400, 115200 bps
Data length	8 bit
Stop bit	1 bit/2 bit *2
Parity bit	None/Odd/ Even
Communication distance	Max.1000m (ideal value)
Error detecting system	CRC-16

*1: An open protocol developed by Modicon for serial communication.

*2: The value of the stop bit is determined automatically by the parity bit setting.

A4-2. Function code

- There is no distinction between Coil and Discrete Input addresses.
- There is no distinction between Holding Register and Input Register addresses.
- Coil, Discrete Input, Holding Register, Input Register addresses start from '0'.

Table A4-2. Supported Function Codes

Function code (hexadecimal)	Function
0x01	Read Coils
0x02	Read Discrete Inputs
0x03	Read Holding Registers
0x04	Read Input Register
0x05	Write Single Coil
0x06	Write Single Register
0x10	Write Multiple Registers

A4-3. Communication specification

- The address range can be used from 1 to 247.
- The maximum frame size that can be communicated at a time is 256 bytes (maximum read registers: 125, maximum write registers: 123).
- The baud rate (bit/sec) can be selected from 2400, 4800, 9600, 19200, 38400 and 115200.
- Parity can be selected from 'Even', 'Odd' or 'None'.
- The bit width is 8 bits, the stop bit is 1 bit when parity is present, and 2 bits when parity is absent.
- If the address and communication settings are changed, the equipment must be restarted.

Table A4-3. Communication setting

Setting No.	Bit rate	Parity
0	2400	None
1	2400	Even
2	2400	Odd
3	4800	None
4	4800	Even
5	4800	Odd
6	9600	None
7	9600	Even
8	9600	Odd
9	19200	None
10 (default)	19200	Even
11	19200	Odd
12	38400	None
13	38400	Even
14	38400	Odd
15	115200	None
16	115200	Even
17	115200	Odd

A4-4. Cable connection

- RS485 communication ground and the power ground are the same.

Be sure to connect the ground of RS485 communication interface to the power ground.

A4-5. Data format

Table A4-4. Data format to use.

Format	Abstract
U16	Unsigned 16bit Integer
S16	Signed 16bit Integer
U32	Unsigned 32bit Integer
S32	Signed 32bit Integer
F32	IEEE754 32bit floating point format
Str	ASCII characters string

- The byte order for communication is big endian.
 2byte values are sent in the order of H byte → L byte
 4byte values are sent in the order of H word → L word
 Character strings are sent in the order of 1 byte from the beginning.
 Allocation of each format is shown in the table below.

Table A4-5. Assignment of 8/16/32 bit value

8bit	0x12	0x34	0x56	0x78
16bit	0x1234(MSW)		0x5678(LSW)	
32bit	0x12345678			

Table A4-6. Assignment of 8/16 bits and F32

8bit	0x41	0x45	0x85	0x1E
16bit	0x4145(MSW)		0x851E(LSW)	
F32	12.345			

Table A4-7. Assignment of 8/16bit and Str

8bit	0x41	0x42	0x43	0x44
16bit	0x4142(MSW)		0x4344(LSW)	
Str	'ABCD'			

- Unless otherwise stated, the 32-bit register is in the order of high word (MSW) followed by low word (LSW).
 The following table shows the cases where 0x12345678 is assigned to address n of Modbus register.

Table A4-8. Relationship between 32-bit values and Modbus registers

32-bit value	0x12345678
Modbus register (address n)	0x1234(MSW)
Modbus register (n+1)	0x5678(LSW)

A4-6. Outline of 1 Holding/Input register map

- The register map starts from address 0.
- Registers No. 0 to 99 are read-only.
- Registers after No.101 can be read or written to.

A4-7. No. 0-49 Register details

- See in parentheses for the unit.
- Fixed value if the content is numeric.
- The blank space is not used. It is filled with zero in U16 format.

Table A4-9. No. 0-49 Register

0	Model	U16	Model number of the transmitter.(MS-57SH:0x0260)
1	0	U16	Fixed value
2	Comp.Irr	F32	Adjusted solar radiation intensity Unit: (W/m ²)
3			
4 to 7 are Reserve			
8	Pt100	F32	Sensor temperature Unit: (°C)
9			
10 to 11 are Reserve			
12	Zenith angle	F32	Zenith angle of the sensor Unit: (°)
13			
14	X-axis tilt angle	F32	X-axis component of the tilt angle Unit: (°)
15			
16	Y-axis tilt angle	F32	Y-axis component of the tilt angle Unit: (°)
17			
18	Raw.Irr	F32	Intensity of solar radiation before correction Unit: (W/m ²)
19			
20	ADmV	F32	Sensor output voltage Unit: (mV)
21			
22	Internal temperature	F32	Temperature measured by the internal temperature sensor Unit: (°C)
23			
24	Internal humidity	F32	Relative humidity measured by the internal humidity sensor Unit: (% RH)
25			
26	Alerts for abnormal internal humidity of the pyrhelimeter	U32	Alerts for abnormalities in the internal humidity of the pyrhelimeter Normal: 0, Abnormality occurs: 1
27			
28	Alerts for abnormal Window heating function of the pyrhelimeter	U32	Alerts for abnormalities in the Window heating function of the pyrhelimeter Normal: 0, Abnormality occurs: 1
29			
30 to 49 are Reserve			

A4-8. Measurement value register update cycle

- The sensor output and the tilt angle measurement value in the register are automatically updated.

The update cycle is about 110 msec. If the data read cycle is less than 110msec, the same data will be read multiple times. The data read cycle should be 110msec or more.

A4-9. Register details from No.50 to 99

- A fixed value of zero (U16) has been written to an address that is not used.
- The 'EKO' character is written as the company name registration in register No. 96 and 97.

Table A4-10. Register No.50-95

50 to 95 are Reserve

Table A4-11. Register No.96-99

96	Company name (0,1)	Str	The company name in ASCII format 'EKO' is read.
97	Company name (2,3)		Four 'EKO' characters, three 'EKO' characters and one space (0x20).
98	Firmware version	U16	Firmware version number.
99	Hardware version	U16	Various parts of hardware

A4-10. No. 101 or later registers

- Registers after No.101 are readable and writable, and values written are immediately reflected.
- To save the written data, use Discrete Coil shown below to save the data.
- The 2 registers, Modbus address (No.101) and serial communication setting (No.102) related to communication are not reflected in the operation after saving and rebooting.

Table A4-12. Register No.100-199

100 is Reserve			
101	Modbus Address	U16	Modbus slave address
102	Serial Communication Setting	U16	Set bit rate and parity, see Table A4-3. 'Communication setting'
103 to 150 are Reserve			
151	Window Heating function	U16	OFF:0, ON:1 (Default)
152 to 161 are Reserve			
162	Date of manufacture	U32	Date of manufacture in YYYYMMDD format
163			
164	Serial number	U32	Serial number with 32-bit integer value (maximum value 4294967295) Enter the number part excluding the alphabet S.
165			
166	Sensor name (0,1)	Str	Sensor name according to ASCII format, up to 16 characters Null-terminated unless all 16 characters are used
167	Sensor name (2,3)		
168	Sensor name (4,5)		
169	Sensor name (6,7)		
170	Sensor name (8,9)		
171	Sensor name (10,11)		
172	Sensor name (12,13)		
173	Sensor name (14,15)		
174 to 181 are Reserve			
182	L.Coeff.k1	F32	Linear correction factor k1
183			
184	L.Coeff.k2	F32	Linear correction factor k2
185			
186	L.Coeff.k3	F32	Linear correction factor k3
187			
188	L.Coeff.k4	F32	Linear correction factor k4
189			
190	Cal.Date	U32	Calibration date in YYYYMMDD format
191			
192	Cal.Value	F32	Calibration value, $\mu\text{V/W}\cdot\text{m}^2$
193			
194 to 199 are Reserve			

Table A4-13. Register No.200-219

200	Cal.Date history0	U32	Calibration History, Date 0
201			
202	Cal.Value history0	F32	Calibration history, sensitivity constant 0
203			
204	Cal.Date history1	U32	Calibration History, Date 1
205			
206	Cal.Value history1	F32	Calibration History, Sensitivity Constant 1
207			
208	Cal.Date history2	U32	Calibration History, Date 2
209			
210	Cal.Value history2	F32	Calibration History, Sensitivity Constant 2
211			
212	Cal.Date history3	U32	Calibration History, Date 3
213			
214	Cal.Value history3	F32	Calibration History, Sensitivity Constant 3
215			
216	Cal.Date history4	U32	Calibration History, Date 4
217			
218	Cal.Value history4	F32	Calibration History, Sensitivity Constant 4
219			

A4-11. Linear correction factor

- Calculate the pyrheliometer output after linear correction using the following equation using the coefficient $k_1/k_2/k_3/k_4$ for the solar radiation meter output $V(\text{raw})$ after temperature correction.
- Linear post-correction sun photometer output $V(L) = k_1 + (k_2 \cdot V(\text{raw})) + (k_3 \cdot V(\text{raw})^2) + (k_4 \cdot V(\text{raw})^3)$
- The default value is $k_2=1, k_1=k_3=k_4=0$, so $V(L)=V(\text{raw})$, and the raw value is used for the corrected pyrheliometer output.

A4-12. Solar irradiance after correction

- After the linear correction and temperature correction written above, using the sensitivity value $S(\mu\text{V}/\text{W} \cdot \text{m}^2)$ for the output voltage, according to the following equation, calculate the irradiance value.

$$\text{Corrected solar irradiance: } I(C) = V(L) \times 1000/S$$

*Since the unit of $V(L)$ is millivolts, multiply it by 1000 to obtain the irradiance value.

A4-13. Outline of Coil / Discrete Input Registers

- Reboot the device and save the settings by writing a specified bit.
- Do not write to any Coil other than Reboot/Save.
- The readout is always zero.

A4-14. Register details

Table A4-14. Coil register

Addr	Parameter	R/W	Type
0	-	-	-
1	Reboot	W	Bit
2	-	-	-
3	Save	W	Bit
4	-	-	-
5	-	-	-
6	-	-	-
7	-	-	-

A-5. Communication specification (SDI-12)

A5-1. Abstract

- SDI-12 (Version:1.4) is supported.
- When SDI-12 is enabled, the unit operates in 'low power standby mode' with power consumption of approx. 2.5mA (at 12V) during non-communication.

A5-2. Communication specification

- The communication specifications of SDI-12 are as follows.

Table A5-1. SDI-12 Communication Specifications

Item	Description
Communications protocols	SDI-12 Version 1.4
Baud rate	1,200 bps
Data length	7bit
Stop bit	1
Parity bit	Even
Communication distance	Within 60 m

A5-3. Command list

- SDI-12 commands are listed below.
- The lowercase letter 'a' in the command list indicates SDI-12 address number.
- SDI-12 address number that can be set is 0-9, A-Z, a-z.

Table A5-2. SDI-12 Commands

Command	Response	Description
?!	a<CR><LF>	Check the address number of the connected device. NOTE: If more than one device is connected, it will not function properly. Be sure to use the device alone.
a!	a<CR><LF>	Verify that the device with address number 'a' is active.
aAb!	b<CR><LF>	Change the address number of the device with address number 'a' to 'b'.
a!	Refer to the right section	Returns information. <Response example> 'a14EKOINST_ MS-57SHV3220000001<CR><LF>' a: SDI-12 address 14: SDI-12 version (represents version 1.4) EKOInst: Company name (8 characters) MS57SH: Sensor model name (6 characters) V32: Sensor version (3 characters) 20000001: Serial number (8 characters)
aM!	a0001<CR><LF>	Request the device with address number 'a' to execute measurement. 0001: indicates the 3-digit measurement execution time (000 indicates instantaneous), and the 4th digit indicates the number of data to be returned (1 piece).
aD0! aD1! aD2! aD3! aD4!	a+1000.0<CR><LF>	Request to send data to the device with address number 'a'. The output value is always appended with a sign (+ or -). If there is more than one output, the sign is also the delimiter. D0: Irradiance (W/m ²) 1 digit after decimal point D1: Sensor output voltage (mV) 4 digits after decimal point and Sensor temperature (Celsius) 2 digits after decimal point D2: X-axis tilt angle (degree) 1 digit after decimal point, forward/backward with connector facing back, positive value when back is up, Y-axis tilt angle (degree) 1 digit after decimal point, left/right with connector facing back, negative value when left is down D3: Internal temperature of pyrhelimeter body (°C) 1 digit after the decimal point, Humidity inside the enclosure (% RH) 1 digit after the decimal point. D4: Alert to notify users of abnormality in the internal humidity and Window heating function of the pyrhelimeter returns 0 for a normal condition and 1 for an abnormal condition. If the pre-measurement command is 'MC', then three CRC characters are followed, please refer to SDI-12 standard for the content of CRC characters.

aMC!	a0011<CR><LF>	Request the device with address number 'a' to start measurement and request the CRC to confirm that the command is correctly accepted. The response format is the same as 'aM!'
aC!	a00101<CR><LF>	This device is the same as the 'aM!' command except for the difference in the number of response characters. The character following a indicates the number of seconds (3 digits) and the number of data (2 digits).
aCC!	a00101<CR><LF>	This transmitter is the same as the 'aMC!' command except for the difference in the number of response characters.
aR0!	a+0.0<CR><LF>	Request a measurement from the device with address number 'a'. Measurement is executed and a response is returned immediately. The answer is similar to 'aD0!' to 'aD2!' command.
aRC0!	a+0.0EmT<CR><LF>	Request measurement from the device with address number 'a' and request error detection to verify that the command was accepted correctly. Measurement is executed and the measured value with three CRC characters added at the end is returned instantly.
aXSE!	a+XX.XX<CR>><LF>	Read the sensitivity constant of this device. Two digits after the decimal point.
aXCD!	aYYYYMMDD<CR><LF>	Read the calibration date of this device. YYYY: AD, MM: month, DD: day.
aXHT!	a+1<CR>><LF>	Reads the Window heating function status. ON:1, OFF:0
aXHT1!	a<CR>><LF>	Change the Window heating function setting to ON.
aXHT0!	a<CR>><LF>	Change the Window heating function setting to OFF.
METADATA	Variable depending on request data	Identify Measurement Commands and Identify Measurement Parameter Commands are supported.

A-6. About recalibration

When recalibrating at a recalibration center other than EKO, the calibration scale of the other center may differ slightly from the pyrheliometer calibration scale and sensitivity constants ($\mu\text{V}/\text{W}\cdot\text{m}^2$) obtained by EKO. The differences may be caused by differences in the calibration method, differences in the reference standard, measurement uncertainty, and measurement conditions.

If a new sensitivity constant was found and needs to be applied to the pyrheliometer, it can be applied in two ways:

- 1) (Post data correction) Multiply the relative difference of the irradiance value measured with the pyrheliometer. In this case, the original factory sensitivity value given by EKO remains unchanged. When the new sensitivity figure was found apply the ratio of the new and original calibration figure according to the formula below:

$$I_{new} [\text{W}/\text{m}^2] = \frac{E [\mu\text{V}]}{S_{original} [\mu\text{V}/\text{W}\cdot\text{m}^2]} \times \frac{S_{original} [\mu\text{V}/\text{W}\cdot\text{m}^2]}{S_{new} [\mu\text{V}/\text{W}\cdot\text{m}^2]}$$

Example:

It was proven that there was a relative difference in irradiance measured by the MS-57SH and the reference pyrheliometer. In this example the irradiance measured by the MS-57SH was lower than the irradiance measured by the reference pyrheliometer, a new sensitivity value can be calculated and applied by the following equation.

$$S_{new} = I_{MS57SH} / I_{ref} \times S_{original}$$

S_{new}	NewMS-57SH Sensitivity ($\mu\text{V}/\text{W}/\text{m}^2$)
S_{origin}	MS-57SH Original Sensitivity ($\mu\text{V}/\text{W}/\text{m}^2$)
I_{MS57SH}	Irradiance measured by the MS-57SH (W/m^2)
I_{ref}	Irradiance measured by reference pyrheliometer (W/m^2)

- 2) (Change the sensitivity figure of the MS-57SH) Set a new sensitivity figure to the MS-57SH. This can be done via through the Hibi software. Connect the MS-57SH to a PC with a RS485/USB converter cable. In settings, the new sensitivity figure can be applied. The original sensitivity figure remains, but will be replaced by the 'last' sensitivity figure ($\mu\text{V}/\text{W}/\text{m}^2$). Multiple calibration figures can be stored inside the pyrheliometer, the 'last' sensitivity figure is the actual one to calculate the irradiance.

A-7. Temperature Response Measurement Test Report

Each MS-57SH Pyrheliometer is shipped with a unique 'Temperature Response Measurement Test Report'. The report shows the temperature response test data when the Window heating function is turned off (disabled).

The window heating function of the MS-57SH can be toggled ON (enabled) or OFF (disabled).

The following figure (Figure A7-1) shows an example of temperature response test data obtained from a single MS-57SH with the Window heating function turned ON and OFF, respectively.

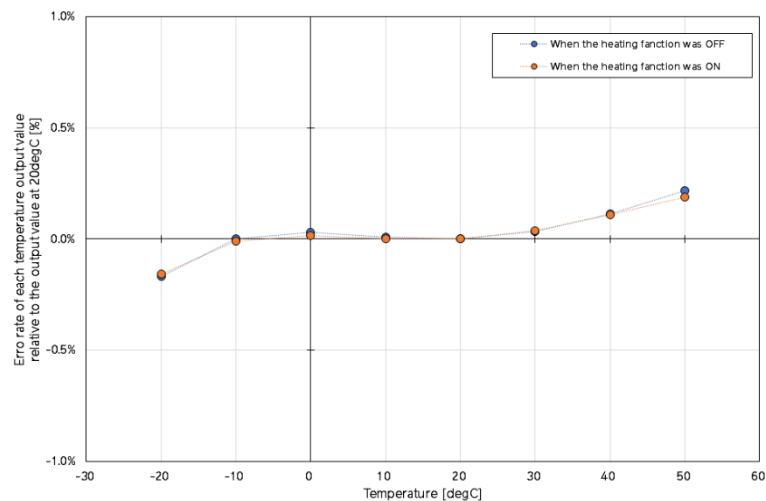

Figure A7-1: Comparison of temperature response when Window heating function is ON and OFF

The energy-efficient window heating function of the MS-57SH heats the entire pyrheliometer housing and maintains the temperature of the quartz window above the outside temperature. The figure above (Figure A7-1) shows that the temperature increases of the housing, caused by the heating function, has almost no effect on the temperature response of the pyrheliometer.

The following figure (Figure A7-2) shows the difference in the error rate of the output value at each temperature setting relative to the output value at an ambient temperature of 20°C. This data shows the test results obtained for 10 units of the MS-57SH with the window heating function ON and OFF, respectively.

The difference in temperature response error rate with the window heating function ON and OFF in the temperature range from -20°C to +50°C is negligible, within $\pm 0.1\%$.

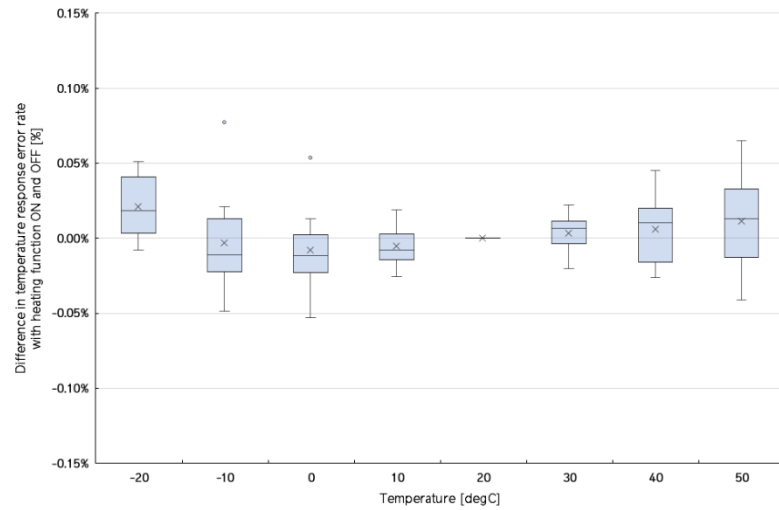

Figure A7-2: *Difference in temperature response error rates for 10 units of MS-57SH with heating function ON and OFF*

These results indicate that the temperature response test report data provided with the product is applicable in any case, regardless of whether the Window heating function is ON or OFF.

A-8. MS-57SH Setting Report



EKO INSTRUMENTS CO.,LTD.
1-21-8 Hatagaya, Shibuya-ku,
Tokyo 151-0072 Japan
P. +81.3.3469.6713
F. +81.3.3469.6719
www.eko.co.jp

SH-series Setting Report

Issue Date:

16-Aug-23

Factory setting data	
Sensor type	Pyrheliometer
Model name	MS-57SH
Serial number (s*****)	S123456.01
Manufacturing date	August 5, 2023
Calibration date	August 4, 2023
Analog sensitivity [μV/W/m ²]	7.656
Hardware version	8
Firmware version (*.***)	7003

Dome Heating Function	Setting
ON/OFF	ON(Default)

Modbus RTU	Setting
Address	1
Baudrate	19200
Parity	EVEN

SDI-12	Setting
Address	0
Baudrate	1200

A-9. Surge protection

Since a surge protection board is embedded inside the pyrhelimeter, this alone provides strong protection against lightning surges.

However, if the pyrhelimeter cable is longer than 10m, or if multiple pyrhelimeter are connected and the total cable length exceeds 10m, the connected loggers, power supply, and other devices may be damaged by lightning surges.

Please refer to the figure below and add an appropriate SPD shall be added to protect the measurement system.

A. Modbus RTU connection (when the cable length exceeds 10m)

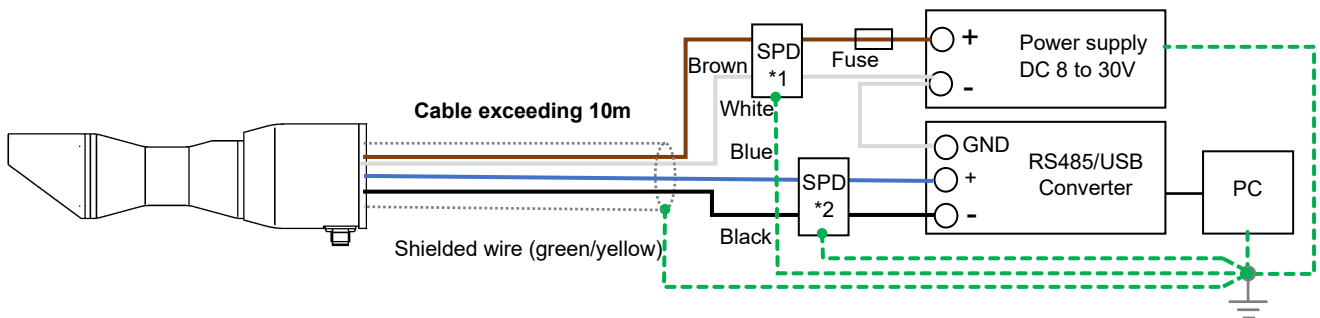

Figure A9-1. Modbus RTU connection (when the cable length exceeds 10m, etc.)

*1 *2

If the cable length exceeds 10m, an SPD for the communication line and an SPD for the DC power supply shall be set up because surges may enter from the communication line and the power supply line.

B. SDI-12 connection (when the cable length exceeds 10m)

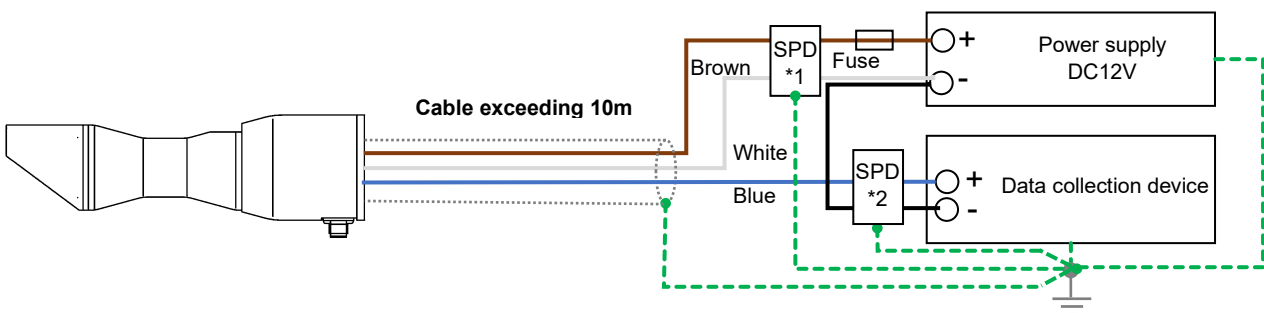

Figure A9-2. SDI-12 connection (when the cable length exceeds 10m, etc.)

*1 *2

If the cable length exceeds 10m, an SPD for the communication line and an SPD for the DC power supply shall be set up because surges may enter from the communication line and the power supply line.

In the case of lightning surges, the more countermeasure components are used, the lower the probability of failure. However, the type, rating, and connection method of the SPD to be used vary depending on the manufacturer, so please read the instruction manual of each manufacturer carefully.



EKO Asia, Oceania

1-21-8 Hatagaya,
Shibuya-ku, Tokyo
151-0072 Japan
P. +81.3.3469.6711
F. +81.3.3469.6719
info@eko-instruments.com
www.eko-instruments.com

EKO North America

111 North Market Street,
Suite 300, San Jose,
CA 95113, USA
P. +1-408-977-7751
F. +1-408-977-7741
sales-usa@eko-instruments.com
www.eko-instruments.com

**EKO Europe,
Middle East, Africa,
South America**

Lulofsstraat 55, Unit 28,
2521 AL, Den Haag,
The Netherlands
P. +31 [0]70 3050117
sales-eu@eko-instruments.com
www.eko-instruments.com